

VERSYS-X 250



CATÁLOGO DE PARTES

Mobil Super™
4T Ultra

Kawasaki

IRC LLANTAS **TECNOLOGÍA JAPONESA**



**Los Expertos en motos
las usan y recomiendan:**

Kawasaki

 **auteco**[®]
www.auteco.com.co

APLICACIONES DE LAS LLANTAS IRC EN LOS MODELOS KAWASAKI

MODELO	APLICACIÓN	MEDIDA	MARCA	GRABADO	TIPO DE GRABADO	CÓDIGO CATALOGO	CÓDIGO SAP
KDX 125	DELANTERA	80/100-21 (Opcional)	IRC	VE35F	CROSS	80/100-21-VE35F-TT	10027743
	TRASERA	410-18		TR1	TRIAL TACO	41070-4018-TR1/18	10020188
KLX 150 (2011 - 2014)	DELANTERA	70/100-19	IRC	GP21F	ROMBO	70/100-19-GP21F-TT	10024077
	TRASERA	90/100-16		GP22R	ROMBO	90/100-16-GP22R-TT	10029260
KLX 150 (2015 - 2016)	DELANTERA	275-21	IRC	GP21F	ROMBO	275-21-GP21F-TT	10012048
	TRASERA	410-18		GP22R	ROMBO	410-18-GP22R-TT	10019175
KMX 125	DELANTERA	2.75x21	IRC	GP1	TRIAL TACO	41070-2721-GP1/18	10020157
	TRASERA	410x18		GP1	TRIAL TACO	41070-4118-GP1/18	10020191
MAGIC II ZX 130	DELANTERA	250-17 (Opcional)	IRC	NF3	SPORT	41070-2517-NF3/18	10020117
				NR72	PISTERA	41070-2517-NR72/18	10020129
	TRASERA	250-17	IRC	NR72	PISTERA	41070-2517-NR72/18	10020129
				NF3	SPORT	41070-2517-NF3/18	10020117
MAGIC 110 K1 CHEER	DELANTERA	250-17	IRC	NR30	PISTERA	41070-2517-NR30/18	10020120
				NR53	PISTERA	41070-2517-NR53/18	10020123
				NR6	SPORT	41070-2517-NR6/18	10020126
	TRASERA	275-17	IRC	NR2	SPORT	41070-2717-NR2/18	10020140
				NR53	PISTERA	41070-2717-NR53/18	10020143
MAX II KAZE 125	DELANTERA	250-17 (Opcional)	IRC	NR53	PISTERA	41070-2517-NR53/18	10020123
	TRASERA	250-17	IRC	NR30	PISTERA	41070-2517-NR30/18	10020120
				NR53	PISTERA	41070-2517-NR53/18	10020123
				NR6	SPORT	41070-2517-NR6/18	10020126
NINJA 250 (2008)	DELANTERA	110/70-17	IRC	RX01	PISTERA	41070-1117-RX01/18	10020095
	TRASERA	130/70-17		RX01	PISTERA	41070-1317-RX01/18	10020115
NINJA 300 Z250 NINJA 250 (2017)	DELANTERA	110/70-17	IRC	RX01	PISTERA	41070-1117-RX01/18	10020095
	TRASERA	140/70-17		RX01	PISTERA	140/70-17-RX01-TL	10004480
VERSYS-X 250	DELANTERA	100/90-19	IRC	GP210	DOBLE PROPÓSITO	100/90-17-GP210-TL	10059654
	TRASERA	130/80-17		GP210	DOBLE PROPÓSITO	130/80-17-GP210-TL	10059655
VICTOR	DELANTERA	275-17	IRC	NR53	PISTERA	41070-2717-NR53/18	10020143
	TRASERA	275/300-18		NR53	PISTERA	41070-3018-NR53/18	10020174
Z250SL	DELANTERA	100/80-17	IRC	MB99 TL	PISTERA	41070-1017-MB99/18	10020074
	TRASERA	130/70-17		MB99 TL	PISTERA	41070-1317MB99/18	10020112

PREFACIO

Es nuestro placer presentarles a ustedes el Catálogo de Partes.

Este Catálogo ha sido especialmente diseñado para ayudarle en la selección de las partes correctas con el fin de mantener el vehículo en las mejores condiciones.

Los repuestos originales están sujetos a un exigente estándar de control de calidad, por lo tanto es necesario que usted sólo use repuestos originales.

En nuestro constante esfuerzo para mejorar la eficiencia y desempeño de su vehículo, las especificaciones, diagramas y número de partes pueden cambiar sin previo aviso. Consecuentemente las descripciones de los repuestos en este Catálogo pueden no ser las finales y definitivas.

Las alteraciones y modificaciones que ocurren en la impresión de este Catálogo, serán informadas a nuestra red, a través de circulares de Servicio o en nuestra página web: www.auteco.com.co accediendo al link repuestos. Es requisito que usted actualice su Catálogo y haga las correcciones necesarias, una vez reciba dichas circulares. Lo anterior le asegurará un rápido y adecuado despacho de sus partes, pues las órdenes están siendo diligenciadas con las referencias más actualizadas.

En caso de necesitar asistencia técnica, comunicarse con el Distribuidor Autorizado o llamar al departamento de Servicios Auteco-Kawasaki.



DIRECTORIO TELEFÓNICO - UN REPUESTOS Y ACCESORIOS ÁREA COMERCIAL Y ASESORES DE VENTAS

NOMBRE	CARGO	ZONA	CELULAR	CORREO ELECTRÓNICO
Alvaro Enrique Carreño	ASESOR COMERCIAL	Magdalena Medio	314 701 17 85	acarreno@auteco.com.co
Andres Julian Giraldo	ASESOR COMERCIAL	Risaralda y Armenia	301 375 43 57	ajgiraldo@auteco.com.co
Bernardo De Jesus Muriel	ASESOR COMERCIAL	Cucuta	312 257 61 75	bmuriel@auteco.com.co
Carlos Humberto Tobon	ASESOR COMERCIAL	Nariño y Putumayo	310 447 36 11	ctobon@auteco.com.co
Carlos Mario Salazar	ASESOR COMERCIAL	Sucre	310 414 88 45	csalazar@auteco.com.co
Eliecer Zamora Vasquez	ASESOR COMERCIAL	Cali y Cauca	313 584 47 13	ezamora@auteco.com.co
Elkin Humberto Gallego	ASESOR COMERCIAL	Sur de Area Metropolitana de Medellin y Amazonas	310 436 25 98	egallego@auteco.com.co
Esmeralda Forero Acosta	ASESOR COMERCIAL	Zona Centro Bogota	313 585 22 07	eforero@auteco.com.co
Gustavo Adolfo Cantillo	ASESOR COMERCIAL	Atlántico	300 447 41 57	gcantillo@auteco.com.co
Hernan Alonso Pedraza	ASESOR COMERCIAL	Pueblos de Condinamarca	311 899 77 28	hpedraza@auteco.com.co
Ivano Alexy Villota Artega	ASESOR COMERCIAL	Sur de Huila y Caqueta	313 767 78 43	ivillota@auteco.com.co
Jaime Alfonso Villalba	ASESOR COMERCIAL	Bolivar	313 584 72 62	javillalba@auteco.com.co
John Jairo Lopez	ASESOR COMERCIAL	Antioquia Norte	310 444 22 15	jlopez@auteco.com.co
Julio Mario Moterroza	ASESOR COMERCIAL	Magdalena	313 585 60 28	jmoterroza@auteco.com.co
Karen Lorena Candanoza	ASESOR COMERCIAL	Zona Sur Bogota	313 585 35 61	kcandanoza@auteco.com.co
Marlon Santiago Blandon	ASESOR COMERCIAL	Cordoba y Bajo Cauca	310 373 90 19	msblandon@auteco.com.co
Miguel Angel Guerrero	ASESOR COMERCIAL	Norte del Valle y Buenaventura	314 772 07 98	mguerrero@auteco.com.co
Miguel Arturo Osorio Ruiz	ASESOR COMERCIAL	Cesar y Guajira	321 799 78 87	mosorio@auteco.com.co
Miller Fabian Acosta	ASESOR COMERCIAL	Zona Norte Bogota	313 585 98 37	macosta@auteco.com.co
Milton Cesar Olaya Carvajal	ASESOR COMERCIAL	Neiva y Norte Huila	310 436 27 42	molaya@auteco.com.co
Nestor Raul Adarve	ASESOR COMERCIAL	Antioquia Sur y Choco	310 436 26 89	nadarve@auteco.com.co
Oscar Alejandro Posada Villa	ASESOR COMERCIAL	Norte Area Metropolitana Medellin y San Andres	314 811 04 09	aposada@auteco.com.co
Rubén Dario Campo Cárdena	ASESOR COMERCIAL	Caldas y Norte de Risaralda	321 799 79 06	rcampo@auteco.com.co
Uberney Ortiz Velez	ASESOR COMERCIAL	Casanare, Vichada, Boyaca	313 672 73 37	uortiz@auteco.com.co
Willinton Franco Tobon	ASESOR COMERCIAL	Tolima	312 257 67 91	wfranco@auteco.com.co
William De Jesus Gutierrez	ASESOR COMERCIAL	Meta	310 407 40 72	wgutierrez@auteco.com.co
Wilson Sabogal	ASESOR COMERCIAL	Bocaramanga y Area Metropolitana	300 542 85 48	wsabogal@auteco.com.co
Herica Linares Riaño	ASESOR COMERCIAL BAJAJ	Bogota	301 247 71 10	hlinares@auteco.com.co
Jorge Mario Gil	ASESOR COMERCIAL BAJAJ	Medellin	313 672 73 53	jpgil@auteco.com.co
Jorge Mario Maya Velez	ASESOR COMERCIAL BAJAJ	Medellin	312 258 93 84	jmaya@auteco.com.co
Meryce Alejandra Cortazar P.	ASESOR COMERCIAL BAJAJ	Cali	320 732 97 60	mcortazar@auteco.com.co
Pilar Katherine Garcia Tique	ASESOR COMERCIAL BAJAJ	Bogota	300 541 93 34	pgarcia@auteco.com.co
Raul De Jesus Foronda	ASESOR COMERCIAL BAJAJ	Santa Marta	312 850 45 74	rforonda@auteco.com.co
Richard Andres Muñoz	ASESOR COMERCIAL BAJAJ	Popayan	321 799 79 26	rmunoz@auteco.com.co
Yeedsander Guzman Garcia	ASESOR COMERCIAL BAJAJ	Barranquilla	300 542 64 59	yguzman@auteco.com.co
Daniel Becerra Martinez	ASESOR COMERCIAL BOUTIQUE	Cali	300 542 43 98	dbecerra@auteco.com.co
German Alfredo Vivas	ASESOR COMERCIAL BOUTIQUE	Bogota	321 799 79 30	gvivas@auteco.com.co
Hilde Alexander Garcia Cano	ASESOR COMERCIAL BOUTIQUE	Medellin	321 641 50 63	hgarcia@auteco.com.co
Franz Caballero Castro	DESARROLLADOR UN RPTOS Y ACCS	BARRANQUILLA	301 375 25 32	fcaballero@auteco.com.co
Gonzalo Adolfo Saldarriaga	DESARROLLADOR UN RPTOS Y ACCS	MEDELLIN	310 406 88 74	gsaldarriaga@auteco.com.co
Gustavo Adolfo Corrales	DESARROLLADOR UN RPTOS Y ACCS	CALI	300 634 67 59	gcorrales@auteco.com.co
Gilberto Eduardo Ocampo	GERENTE REGIONAL ZONA SUR	GERENTE REGIONAL ZONA SUR	311 382 85 14	eocampo@auteco.com.co
Jhon Alexander Estrada Bello	GERENTE REGIONAL ZONA NORTE	GERENTE REGIONAL ZONA NORTE	311 737 37 48	jestrada@auteco.com.co
Jose Giovanni Suarez Martinez	GERENTE REGIONAL ZONA CENTRO	GERENTE REGIONAL ZONA CENTRO	320 766 49 45	jsuarez@auteco.com.co
Juan Guillermo Ospina	GERENTE COMERCIAL BAJAJ		313 767 78 36	jgospina@auteco.com.co
Laura Ocampo	COORDINADORA ALTA GAMA		320 682 09 64	locampo@auteco.com.co

SERVICIO AL CLIENTE

LINEA ÚNICA DE SERVICIO AL CLIENTE CANAL (4) 444 81 90

UN DE REPUESTOS y ACCESORIOS • FAX OFICINAS: 373 03 75

ATENCIÓN EN:	NOMBRE	E-MAIL	TELÉFONO	FAX
SERVICIO A CONCESIONARIO Y MAYORISTAS	JHONATAN ZAPATA	servicioadistribuidoresymayoristas@auteco.com.co	(4) 444 81 90 OPCION (2)	
SERVICIO PAGO ANTICIPADO	DORIS CARMONA	serviciopagoanticipadorptos@auteco.com.co		(4) 373 83 94
COORDINADOR SERVICIO POSTVENTA	LUIS G. RODRIGUEZ	lrodriguez@auteco.com.co		
GARANTÍAS	ALEJANDRO FERNÁNDEZ	garantias2@auteco.com.co		
DEVOLUCIONES - RECLAMOS	LEONARDO AGUDELO	devolucionesyreclamos@autecocolombia.onmicrosoft.com		
MOTO FUERA DE RUTA	JONI HOLGUIN	motofueraderuta@auteco.com.co		
LÍNEA DE ATENCIÓN AL CLIENTE		devolucionesrptos@auteco.com.co		
POSCONSUMO BATERIAS	YUDY DUQUE	yduque@auteco.com.co	3004243097	
CARTERA		cartera@auteco.com.co		(4) 277 5117
				(4) 306 81 54
VENTA MOTOS		pedidosmotos@auteco.com.co		(4) 372 62 95

AUTOTECNICA COLOMBIANA S.A.S (AUTECO S.A.S) SEDE PRINCIPAL Cra. 42 N° 45-77 Itagüí Ant. - PBX: (4)306 81 81
Atención a clientes finales: LÍNEA GRATUITA NACIONAL - 01 8000 52 00 90

ÍNDICE

FIGURA Nº	DESCRIPCIÓN	PÁG. Nº	FIGURA Nº	DESCRIPCIÓN	PÁG. Nº
B-3	CULATA	1	D-13	CAMPANA DELANTERA	35
B-4	CUBIERTA CULATA	2	D-14	CAMPANA TRASERA	36
B-5	CILINDRO / PISTÓN	3	E-3	PEDAL FRENO	37
B-6	FILTRO DE AIRE	4	E-4	BOMBA FRENO DELANTERO	38
B-7	SILENCIADOR	5	E-5	DISCO FRENO DELANTERO	39
B-8	VÁLVULAS	6	E-6	BOMBA FRENO TRASERO	40
B-9	EJE DE LEVAS / TENSOR CADENILLA	7	E-7	DISCO FRENO TRASERO	41
B-10	CIGÜEÑAL	8	E-8	MANUBRIO / ESPEJOS	42
B-11	CLUTCH	9	E-9	SUSPENSIÓN DELANTERA	43
B-12	TRANSMISIÓN	10	E-10	TANQUE DE GASOLINA	44
B-13	SELECTOR DE CAMBIOS	11	E-11	SILLÍN	45
B-14	EJE DE CAMBIOS	12	E-12	VELOCÍMETRO	46
C-3	CARCASAS	13	E-13	CABLES	47
C-4	TORNILLOS CARCASA MOTOR	14	E-14	CUBIERTA SILLÍN / GUARDACADENA	48
C-5	CUBIERTAS DE MOTOR	15	F-3	FAROLA	49
C-6	SISTEMA DE INYECCIÓN	16	F-4	STOP	50
C-7	BOMBA DE GASOLINA	17	F-5	DIRECCIONALES	51
C-8	UNIDAD DE CONTROL ELECTRÓNICA (E.C.U.)	18	F-6	EQUIPO ELÉCTRICO	52
C-9	BOMBA DE ACEITE	19	F-7	SWICHE DE ENCENDIDO	53
C-10	VOLANTE / PLATO DE BOBINAS	20	F-8	HERRAMIENTAS	54
C-11	SISTEMA DE ENCENDIDO	21	F-9	CALCOMANÍAS VERDE	55
C-12	MOTOR DE ARRANQUE	22	F-10	CALCOMANÍAS GRIS	56
C-13	RADIADOR	23	F-11	CARENAJE SUPERIOR	57
C-14	BOMBA DE AGUA	24	F-12	CARENAJE INFERIORES	58
D-3	CHASIS	25	F-13	ACCESORIO (CORTAVIENTOS)	59
D-4	SOPORTES DE MOTOR	26	G-03	ACCESORIO (MALETEROS)	60
D-5	PARTES DEL CHASIS	27	G-04	ACCESORIO (GATO CENTRAL)	61
D-6	BRAZO OSCILANTE	28	G-05	ACCESORIO (EXPLORADORAS)	62
D-7	SUSPENSIÓN TRASERA	29	G-06	ACCESORIO (SWICHE CORRIENTE DC 12V)	63
D-8	REPOSAPIES	30	G-07	ACCESORIOS (PROTECTOR MOTOR)	64
D-9	GUARDABARRO DELANTERO	31	G-08	ACCESORIO (PROTECTOR TANQUE GASOLINA)	65
D-10	GUARDABARRO TRASERO	32	G-09	ACCESORIO (SILLÍN DOBLE ALTURA)	66
D-11	GATO LATERAL	33	G-10	ACCESORIO (RELAY PARA ACCESORIOS ELECTRICOS)	67
D-12	LLANTAS	34		ÍNDICE NUMÉRICO DE REFERENCIAS	68 - 73

ÍNDICE DE GRÁFICOS

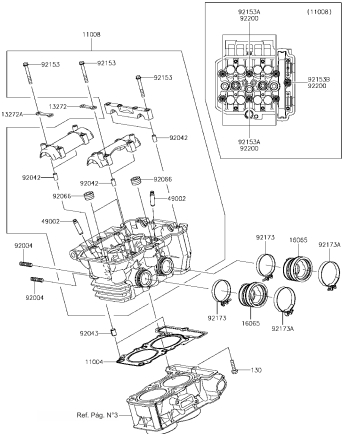
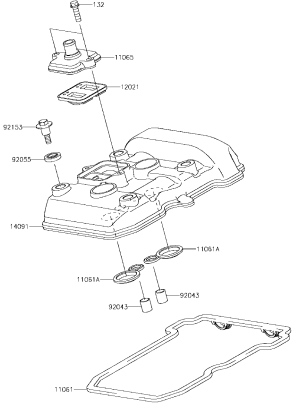
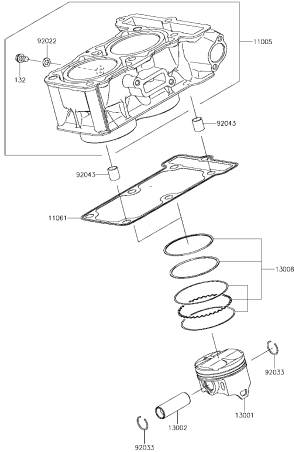
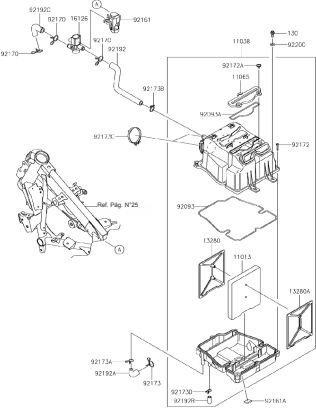
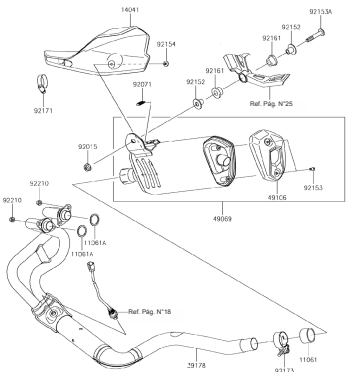
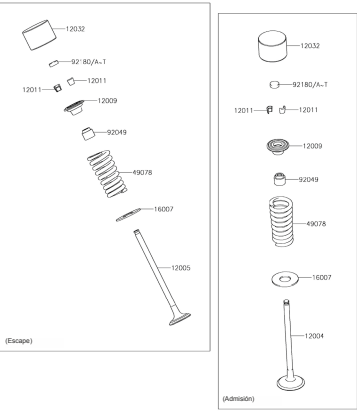
					
<p>B-3: CULATA</p>	<p>PÁG. N° 1</p>	<p>B-4: CUBIERTA CULATA</p>	<p>PÁG. N° 2</p>	<p>B-5: CILINDRO / PISTÓN</p>	<p>PÁG. N° 3</p>
		 <p>(Escape)</p> <p>(Admission)</p>			
<p>B-6: FILTRO DE AIRE</p>	<p>PÁG. N° 4</p>	<p>B-7: SILENCIADOR</p>	<p>PÁG. N° 5</p>	<p>B-8: VÁLVULAS</p>	<p>PÁG. N° 6</p>

ÍNDICE DE GRÁFICOS

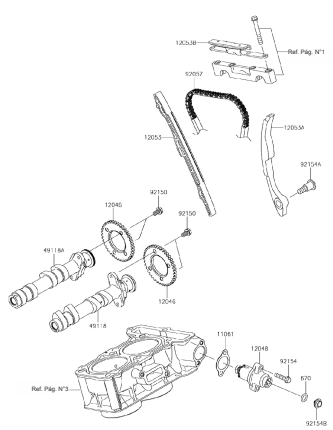
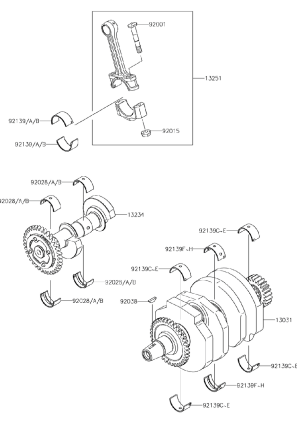
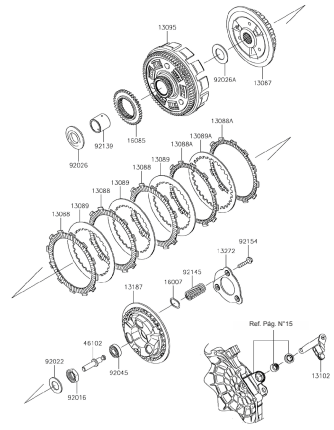
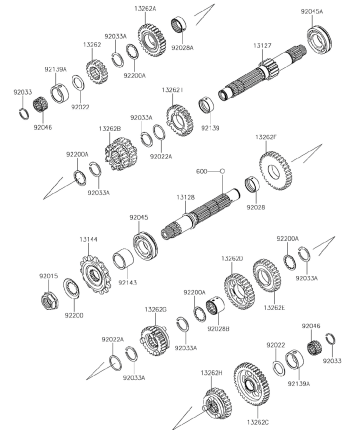
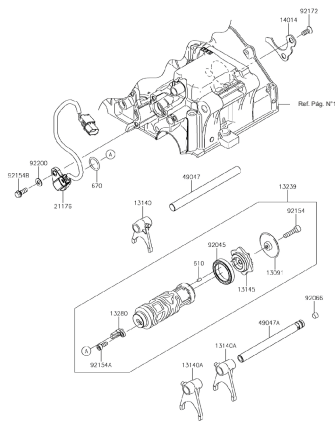
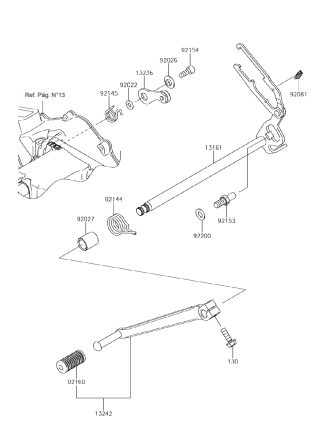
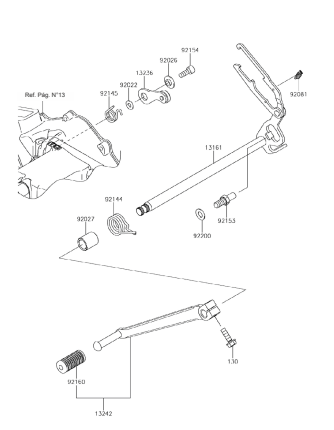
			
B-9: EJE DE LEVAS / TENSOR CADENILLA	PÁG. Nº 7	B-10: CIGÜEÑAL	PÁG. Nº 8
			
B-12: TRANSMISIÓN	PÁG. Nº 10	B-13: SELECTOR DE CAMBIOS	PÁG. Nº 11
		B-14: EJE DE CAMBIOS	PÁG. Nº 12

ÍNDICE DE GRÁFICOS

<p>Diagram showing the chassis (D-3) with various components labeled. Ref. Pág. N°43 is indicated.</p>	<p>Diagram showing the motor supports (D-4) with various components labeled. Ref. Pág. N°25 is indicated.</p>	<p>Diagram showing the chassis parts (D-5) with various components labeled. Ref. Pág. N°25 is indicated.</p>	<p>D-3: CHASIS</p>	<p>PÁG. N° 25</p>	<p>D-4: SOPORTES DE MOTOR</p>	<p>PÁG. N° 26</p>	<p>D-5: PARTES DEL CHASIS</p>	<p>PÁG. N° 27</p>
<p>Diagram showing the oscillating arm (D-6) with various components labeled. Ref. Pág. N°25 is indicated.</p>	<p>Diagram showing the rear suspension (D-7) with various components labeled. Ref. Pág. N°25 and Ref. Pág. N°28 are indicated.</p>	<p>Diagram showing the rear wheel assembly (D-8) with various components labeled. Ref. Pág. N°25 is indicated.</p>	<p>D-6: BRAZO OSCILANTE</p>	<p>PÁG. N° 28</p>	<p>D-7: SUSPENSIÓN TRASERA</p>	<p>PÁG. N° 29</p>	<p>D-8: REPOSAPIES</p>	<p>PÁG. N° 30</p>

ÍNDICE DE GRÁFICOS

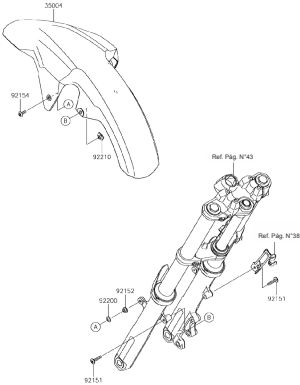
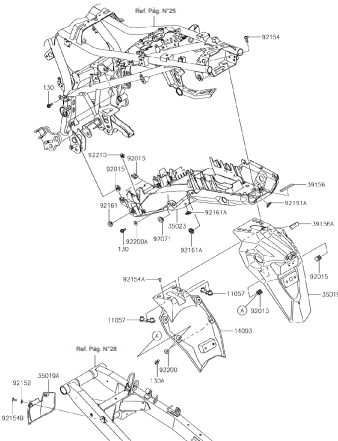
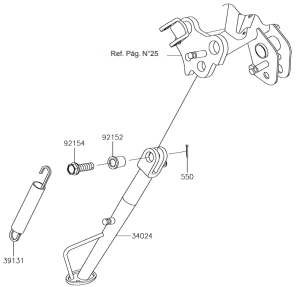
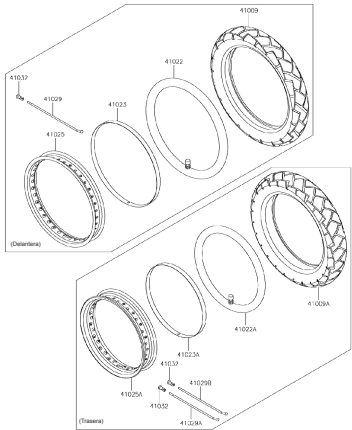
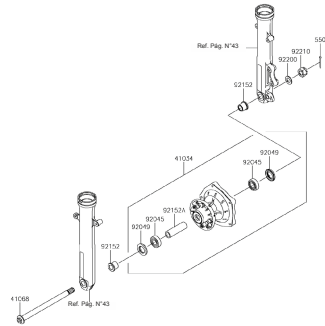
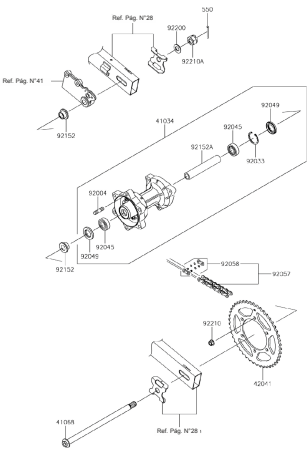
			
D-9: GUARDABARRO DELANTERO	PÁG. N° 31	D-10: GUARDABARRO TRASERO	PÁG. N° 32
			
D-12: LLANTAS	PÁG. N° 34	D-13: CAMPANA DELANTERA	PÁG. N° 35
		D-14: CAMPANA TRASERA	PÁG. N° 36

ÍNDICE DE GRÁFICOS

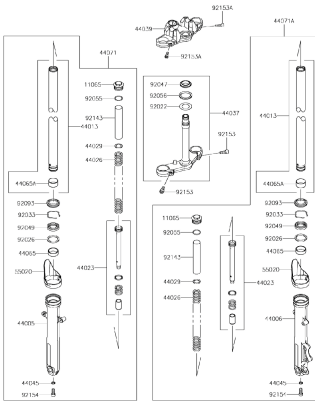

E-9: SUSPENSIÓN DELANTERA

PÁG. Nº 43

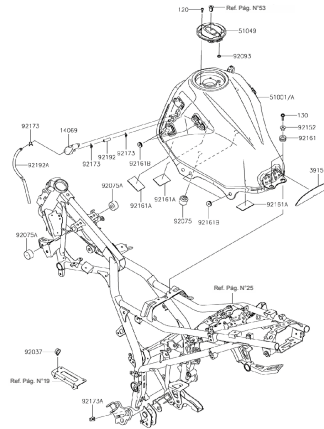

E-10: TANQUE DE GASOLINA

PÁG. Nº 44

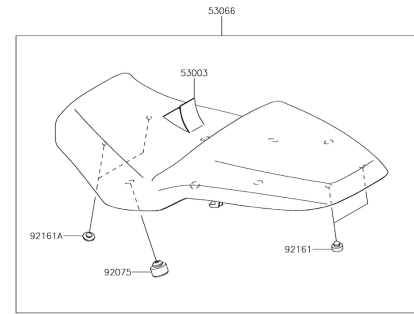

E-11: SILLÍN

PÁG. Nº 45

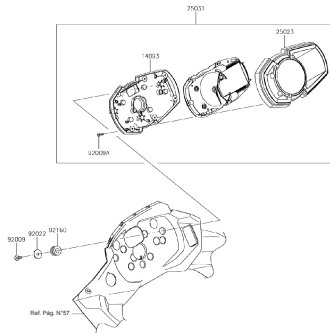

E-12: VELOCÍMETRO

PÁG. Nº 46

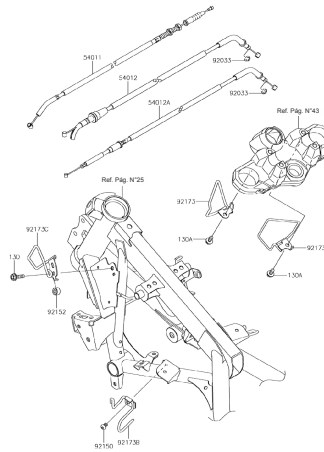

E-13: CABLES

PÁG. Nº 47

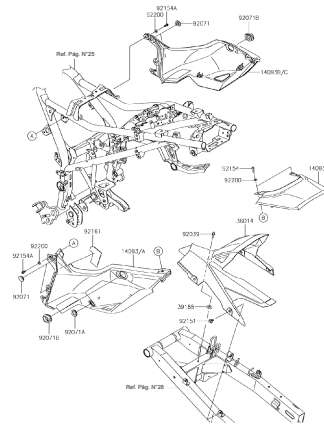

E-14: CUBIERTA SILLÍN /
GUARDACADENA

PÁG. Nº 48

ÍNDICE DE GRÁFICOS

<p>F-3: FAROLA</p>	<p>PÁG. Nº 49</p>	<p>F-4: STOP</p>	<p>PÁG. Nº 50</p>
<p>F-5: DIRECCIONALES</p>	<p>F-6: EQUIPO ELÉCTRICO</p>	<p>F-7: SWICHE DE ENCENDIDO</p>	<p>PÁG. Nº 52</p>
<p>F-8: HERRAMIENTA</p>	<p>PÁG. Nº 53</p>	<p>PÁG. Nº 54</p>	<p>PÁG. Nº 55</p>

ÍNDICE DE GRÁFICOS

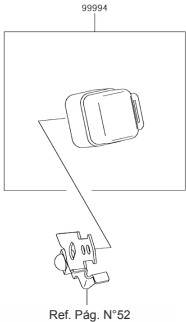
 <p>99994</p> <p>Ref. Pág. N°52</p>			
G-10: ACCESORIO (RELAY PARA ACCESORIOS ELÉCTRICOS)	PÁG. N° 67		

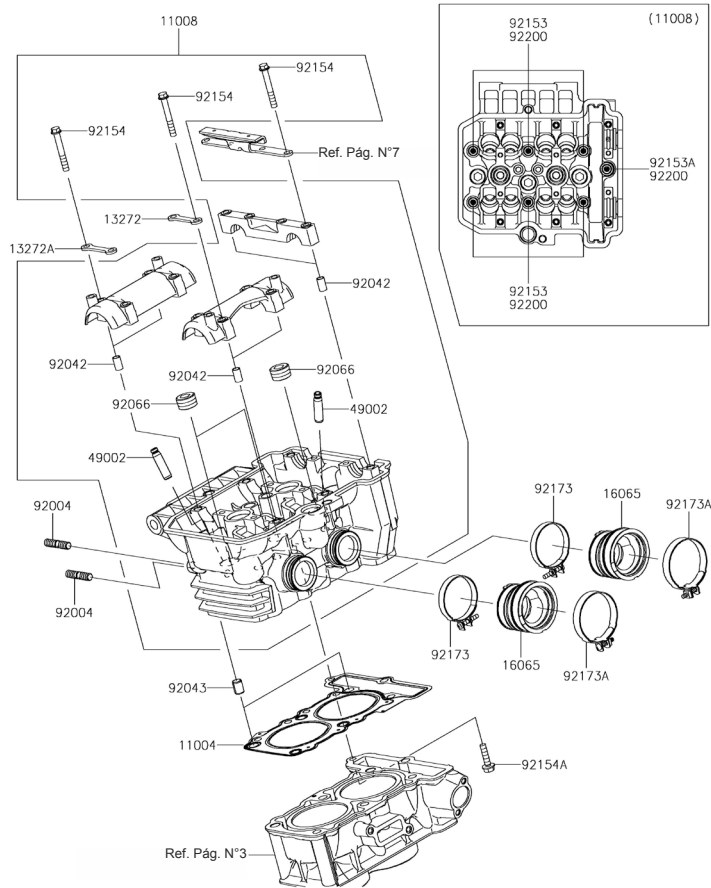

Fig N°	Parte No.	Descripción	18
			CJF
11004	11004-0734	Empaque Culata	1
11008	11008-0748	Culata Completa	1
13272	13272-0260	Platina	2
13272A	13272-0261	Platina	2
16065	16065-0120	Conector Carburador	2
49002	49002-0009	Guía Válvula	8
92004	92004-0040	Esparrago 8x22	4
92042	92042-007	Pin Guía 6.3x8x14	6
92043	92043-1264	Pin Guía 8.2x10x14	2
92066	92066-0002	Tapón Culata	3
92153	92153-1774	Tornillo 8x146	6
92153A	92153-1775	Tornillo 8x115	1
92154	92154-0246	Tornillo 6x45	12
92154A	92154-2556	Tornillo 6x25	1
92173	92173-0919	Abrazadera 47 mm.	2
92173A	92173-0956	Abrazadera 53 mm.	2
92200	92200-0860	Arandela 8.5x18x1.6	7

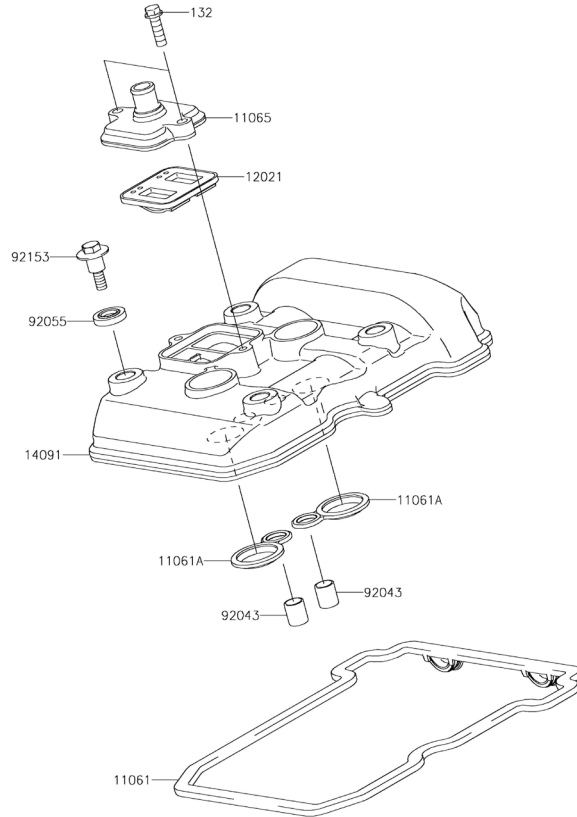

Fig N°	Parte No.	Descripción	18
			CJF
11061	11061-0282	Empaque Tapa Culata	1
11061A	11061-0283	Empaque Guía Bujías	2
11065	11065-0349	Tapa Válvula Torque	1
12021	12021-0708	Válvula Torque	1
14091	14091-0724	Tapa Culata	1
92043	92043-4009	Pin Guía Culata 10.1x12x14	2
92055	92055-0195	Reten Tornillo Tapa Culata	4
92153	92153-0793	Tornillo Tapa Culata	4
132	132BA0620	Tornillo 6x20	2

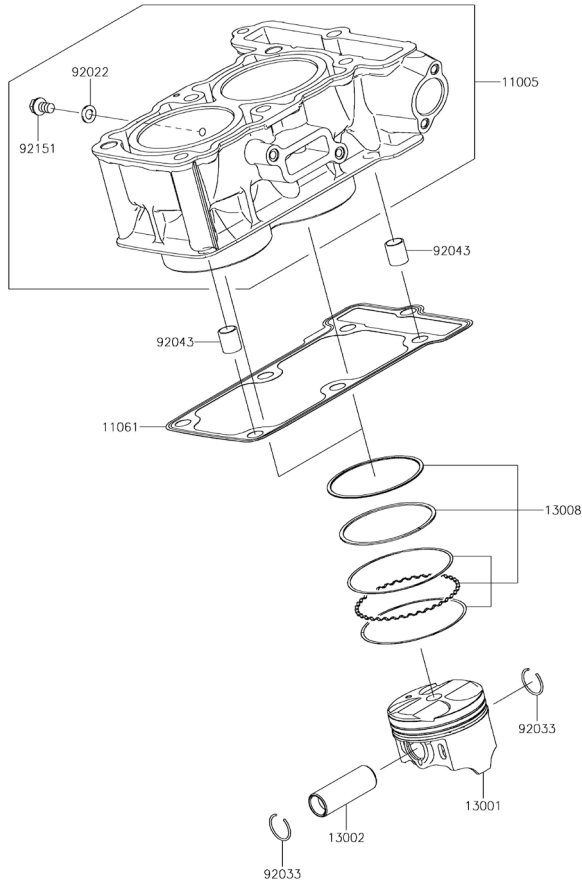

Fig N°	Parte No.	Descripción	18
			CJF
11005	11005-0682	Cilindro	1
11061	11061-0790	Empaque Cilindro	1
13001	13001-0728	Pistón STD	2
13002	13002-1097	Pasador Pistón	2
13008	13008-0047	Anillos STD	2
92022	92022-304	Arandela 6.2x11x1	1
92033	92033-0732	Pin Pasador Pistón	4
92043	92043-1264	Pin Guía 8.2x10x14	2
92151	92151-1233	Tornillo 6x10	1

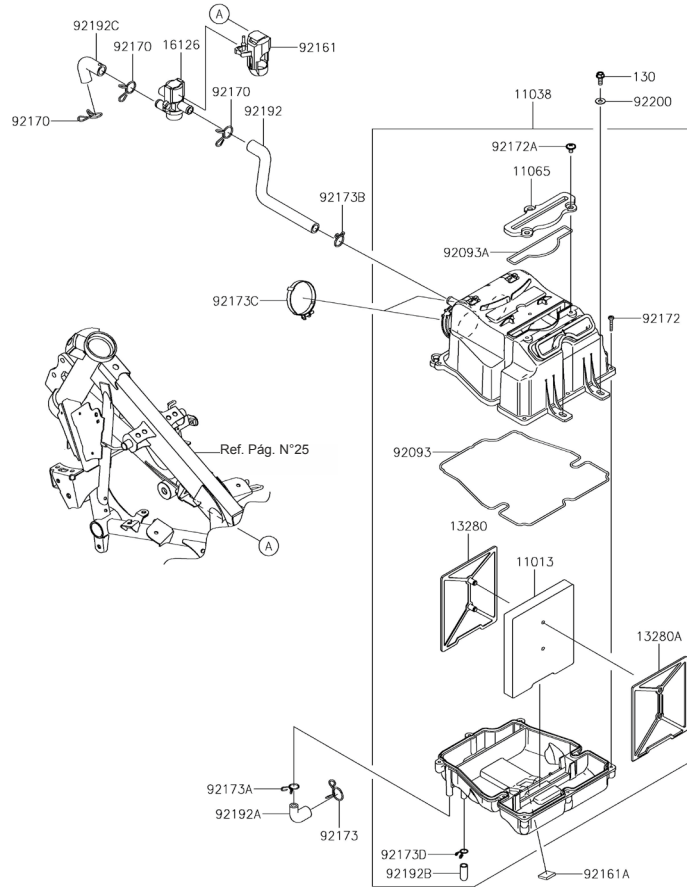

Fig N°	Parte No.	Descripción	18
			CJF
11013	11013-0762	Filtro Aire	1
11038	11038-0049	Caja Filtro Aire Completa	1
11065	11065-0967	Tapa Caja Filtro Aire	1
13280	13280-0883	Soporte Elemento Filtro Aire	1
13280A	13280-0884	Soporte Elemento Filtro Aire	1
16126	16126-0744	Válvula de Aire	1
92093	92093-0698	Empaque Caja Filtro Aire	1
92093A	92093-0699	Empaque Tapa Caja Filtro Aire	1
92161	92161-1424	Antivibrante	1
92161A	92161-1992	Antivibrante 20x20x4	1
92170	92170-1017	Abrazadera	3
92172	92172-0803	Tornillo 5x25	8
92172A	92172-1144	Tornillo 6x10	3
92173	92173-0190	Abrazadera	1
92173A	92173-0192	Abrazadera	1
92173B	92173-0193	Abrazadera	1
92173C	92173-1653	Abrazadera	2
92173D	92173-1714	Abrazadera	1
92192	92192-1727	Conducto	1
92192A	92192-1728	Conducto	1
92192B	92192-1744	Conducto	1
92192C	92192-1763	Conducto ACV Culata	1
92200	92200-0796	Arandela 6.5x16x1.0	2
130	130BA0616	Tornillo 6x16	2

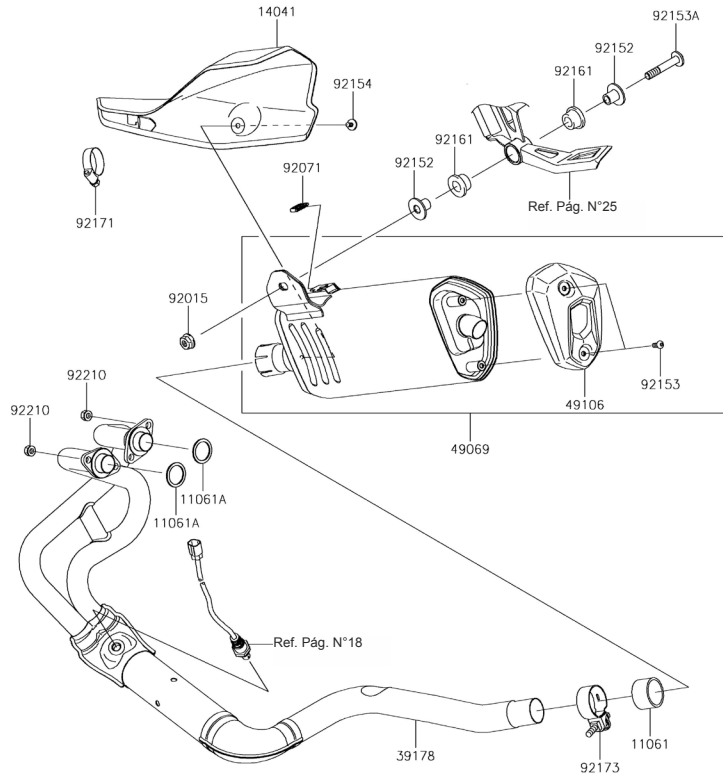

Fig N°	Parte No.	Descripción	18
			CJF
11061	11061-0432	Empaque Tubo Escape	1
11061A	11061-0791	Empaque Tubo Escape	2
14041	14041-0601	Cubierta Silenciador	1
39178	39178-0272	Tubo Escape Completo	1
49069	49069-0825	Silenciador	1
49106	49106-0818	Tapa Silenciador	1
92015	92015-1387	Tuerca 10 mm.	1
92071	92071-0712	Antivibrante	1
92152	92152-2295	Buje	2
92153	92153-1886	Tornillo 6x14	2
92153A	92153-1930	Tornillo 10x58	1
92154	92154-2558	Tornillo 6x10	1
92161	92161-1497	Antivibrante	2
92171	92171-0059	Abrazadera	1
92173	92173-0942	Abrazadera 42 mm.	1
92210	92210-1242	Tuerca 8 mm.	4

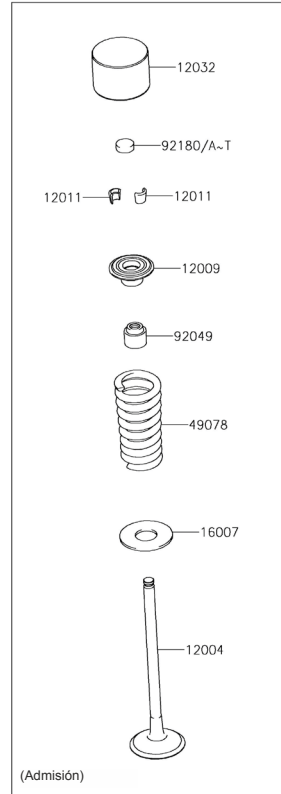
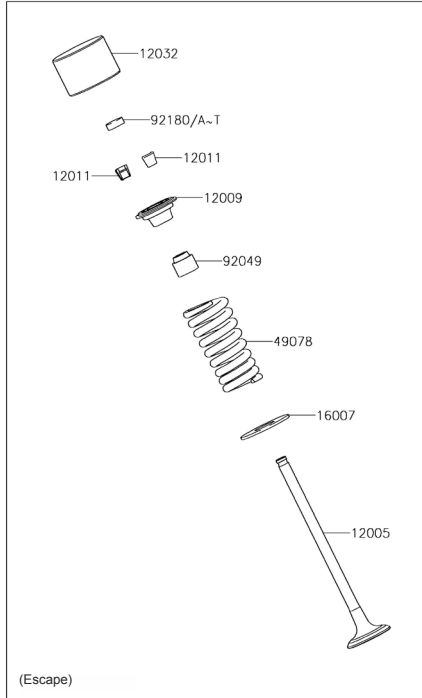

Fig N°	Parte No.	Descripción	'18
			CJF
12004	12004-0749	Válvula de Admisión	4
12005	12005-0770	Válvula de Escape	4
12009	12009-1073	Arandela Resorte Válvula	8
12011	12011-1053	Cuña Válvula	16
12032	12032-0018	Impulsador Válvula	8
16007	16007-0028	Asiento Resorte Válvula	8
49078	49078-0077	Resorte Válvula	8
92049	92049-1349	Reten Válvula	8
92180	92180-1014	Arandela Calibración Válvula 2.50	8
92180A	92180-1016	Arandela Calibración Válvula 2.55	SR
92180B	92180-1018	Arandela Calibración Válvula 2.60	SR
92180C	92180-1020	Arandela Calibración Válvula 2.65	SR
92180D	92180-1022	Arandela Calibración Válvula 2.70	SR
92180E	92180-1024	Arandela Calibración Válvula 2.75	SR
92180F	92180-1026	Arandela Calibración Válvula 2.80	SR
92180G	92180-1028	Arandela Calibración Válvula 2.85	SR
92180H	92180-1030	Arandela Calibración Válvula 2.90	SR
92180I	92180-1032	Arandela Calibración Válvula 2.95	SR
92180J	92180-1034	Arandela Calibración Válvula 3.00	SR
92180K	92180-1036	Arandela Calibración Válvula 3.05	SR
92180L	92180-1038	Arandela Calibración Válvula 3.10	SR
92180M	92180-1040	Arandela Calibración Válvula 3.15	SR
92180N	92180-1042	Arandela Calibración Válvula 3.20	SR
92180O	92180-1044	Arandela Calibración Válvula 3.25	SR
92180P	92180-1046	Arandela Calibración Válvula 3.30	SR
92180Q	92180-1048	Arandela Calibración Válvula 3.35	SR
92180R	92180-1050	Arandela Calibración Válvula 3.40	SR
92180S	92180-1052	Arandela Calibración Válvula 3.45	SR
92180T	92180-1054	Arandela Calibración Válvula 3.50	SR

***SR: Según se Requiera**

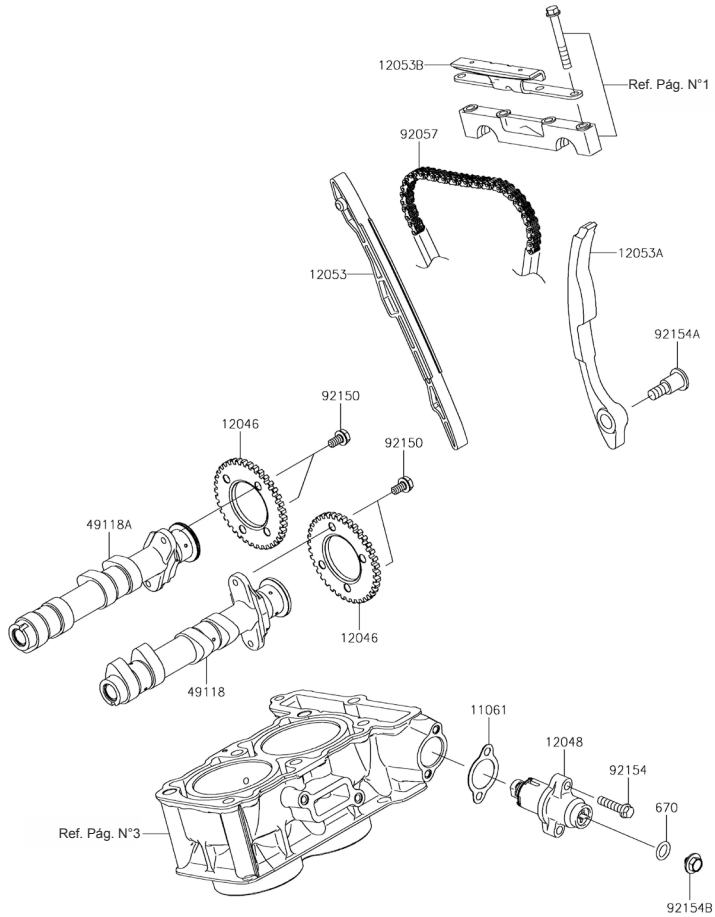

Fig N°	Parte No.	Descripción	18
			CJF
11061	11061-0792	Empaque Tensor Cadenilla	1
12046	12046-0072	Piñon Eje Levas 38T	2
12048	12048-0084	Tensor Cadenilla	1
12053	12053-0102	Guía Cadenilla	1
12053A	12053-0191	Guía Cadenilla Lado Tensor	1
12053B	12053-0235	Guía Culata	1
49118	49118-0742	Eje Levas Admisión	1
49118A	49118-0743	Eje Levas Escape	1
92057	92057-0595	Cadenilla Distribucion	1
92150	92150-1725	Tornillo 6x11	4
92154	92154-0819	Tornillo 6x25	2
92154A	92154-0953	Tornillo 8x29.2	1
92154B	92154-2352	Tornillo 6x6	1
670	670D2010	Anillo Retenedor 10 mm.	1

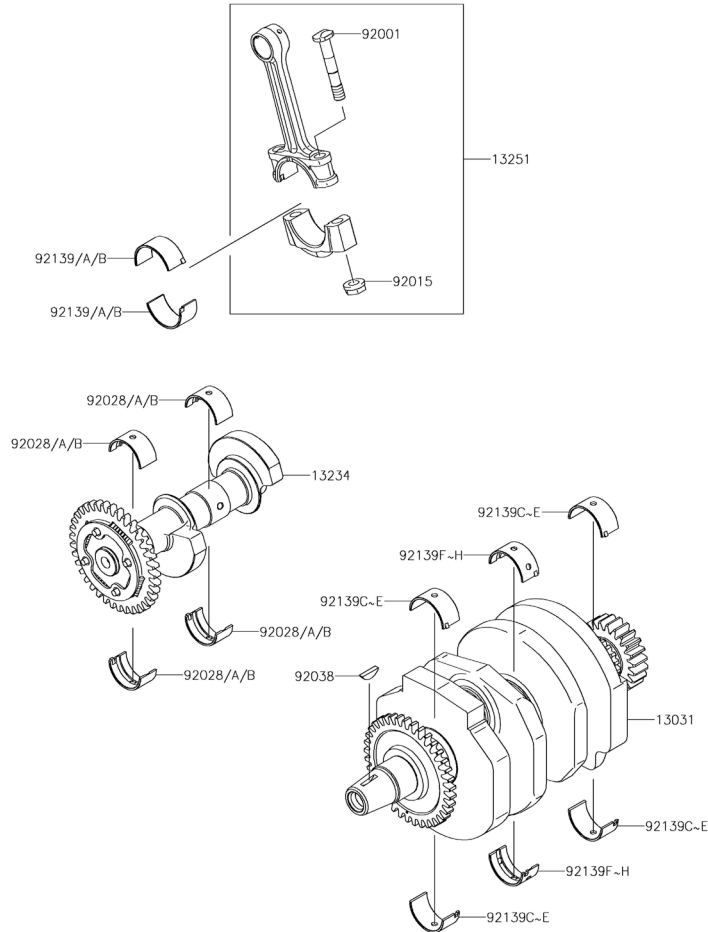

Fig N°	Parte No.	Descripción	18
			CJF
13031	13031-0769	Cigüeñal	1
13234	13234-0598	Eje Balanceador	1
13251	13251-0038-HH	Biela Cigüeñal	2
92001	92001-1793	Tornillo Biela Cigüeñal	4
92015	92015-1527	Tuerca Biela	4
92028	92028-1422	Casquete Balanceador Azul	4
92028A	92028-1423	Casquete Balanceador Negro	SR
92028B	92028-1424	Casquete Balanceador Café	SR
92038	92038-001	Cuna Cigüeñal	1
92139	92139-0782	Casquete Biela Azul	SR
92139A	92139-0783	Casquete Biela Negro	4
92139B	92139-0784	Casquete Biela Café	SR
92139C	92139-0786	Casquete Cigüeñal Azul #1/#3	SR
92139D	92139-0787	Casquete Cigüeñal Negro #1/#3	SR
92139E	92139-0788	Casquete Cigüeñal Amarillo #1/#3	4
92139F	92139-0790	Casquete Cigüeñal Azul #2	SR
92139G	92139-0791	Casquete Cigüeñal Negro #2	SR
92139H	92139-0792	Casquete Cigüeñal Amarillo #2	2

***SR: Según se Requiera**

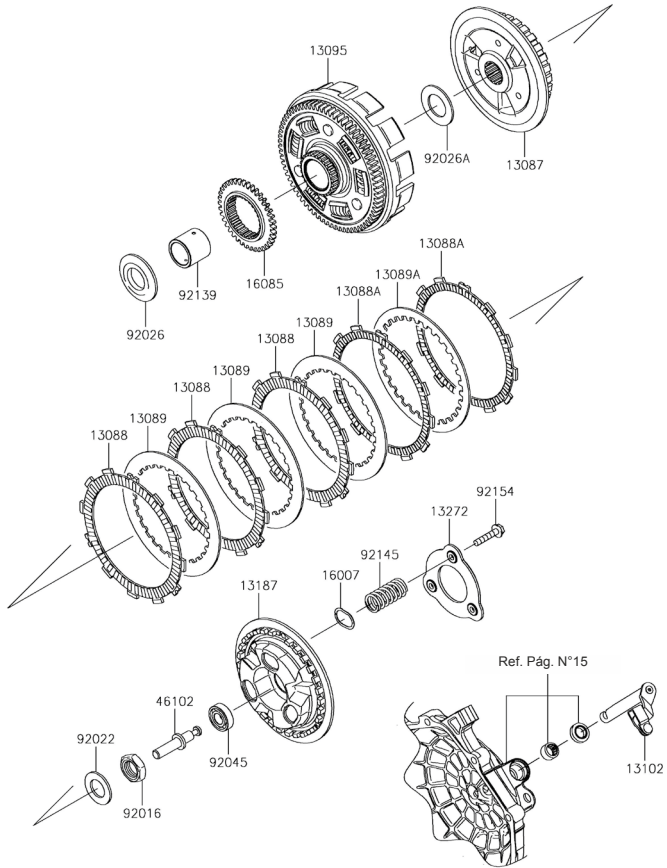

Fig N°	Parte No.	Descripción	18
			CJF
13087	13087-0558	Corona Interna Clutch	1
13088	13088-0590	Disco Clutch	3
13088A	13088-0591	Disco Clutch	2
13089	13089-0021	Disco Separador Clutch	3
13089A	13089-0558	Disco Separador Clutch	1
13095	13095-0561	Corona Clutch	1
13102	13102-0073	Leva Clutch	1
13187	13187-0553	Porta Resortes Clutch	1
13272	13272-1303	Platina Porta Resortes Clutch	1
16007	16007-0708	Asiento Resorte Clutch	3
16085	16085-0133	Piñon Primario 38T	1
46102	46102-0573	Eje Interno Clutch	1
92016	92016-028	Tuerca 20 mm.	1
92022	92022-1116	Arandela 20.3x36x2.3	1
92026	92026-0115	Arandela 25x52x5.5	1
92026A	92026-0734	Arandela 25.5x44.5x2	1
92045	92045-0067	Rodamiento Bolas	1
92139	92139-0773	Buje 25x32x29.1 mm.	1
92145	92145-1750	Resorte Clutch	3
92154	92154-0997	Tornillo 6x30	3

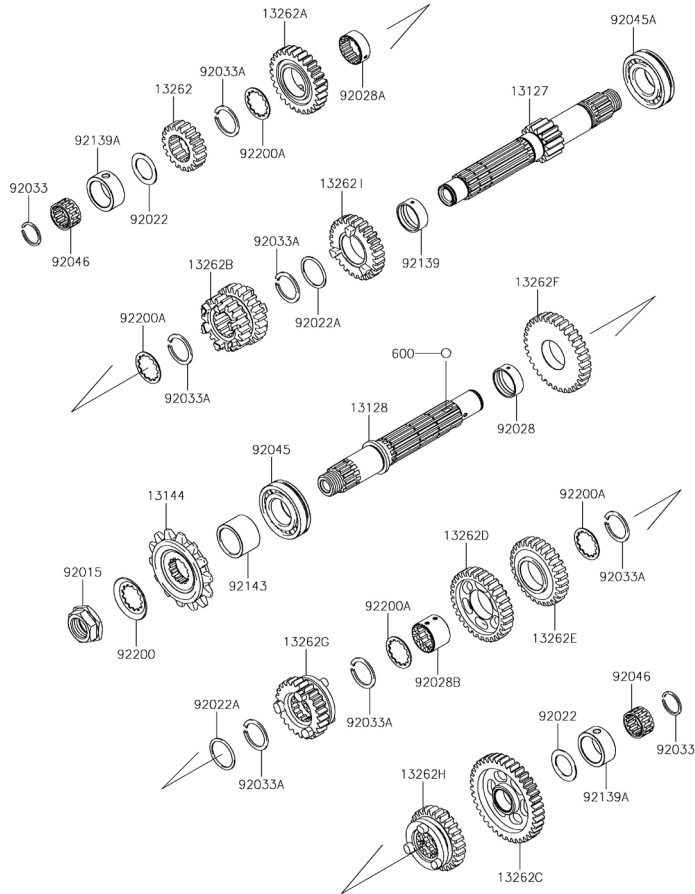

Fig N°	Parte No.	Descripción	18
			CJF
13127	13127-0051	Eje Clutch	1
13128	13128-0693	Eje Salida	1
13144	13144-0577	Piñón de Salida 14T	1
13262	13262-0461	Piñón de 2a. 19T	1
13262A	13262-0463	Piñón Eje Clutch 28T	1
13262B	13262-0464	Piñón de 3a. y 4a. 22T y 25T	1
13262C	13262-0465	Piñón Eje Salida 39T	1
13262D	13262-0466	Piñón de 3a. 31T	1
13262E	13262-0467	Piñón de 4a. 29T	1
13262F	13262-0468	Piñón de 2a. 34T	1
13262G	13262-0469	Piñón Eje Salida 25T	1
13262H	13262-0470	Piñón de 5a. 27T	1
13262I	13262-0922	Piñón Eje Clutch 5a. 27T	1
92015	92015-1963	Tuerca 20 mm.	1
92022	92022-112	Arandela 20.5x30x1	2
92022A	92022-161	Arandela 25.3x30x1	2
92028	92028-1564	Buje 9.4x25x28	1
92028A	92028-1857	Buje Eje Clutch	1
92028B	92028-1858	Buje Eje Salida 3a. y 4a.	1
92033	92033-015	Pin Seguridad 20 mm.	2
92033A	92033-026	Pin Seguridad 24 mm.	6
92045	92045-0735	Rodamiento Bolas 6TM-6205NX3	1
92045A	92045-1013	Rodamiento Bolas 6205NX3	1
92046	92046-0607	Rodamiento 20X25X128	2
92139	92139-0793	Buje 25x28x10.4	1
92139A	92139-0872	Buje 25x33x14	2
92143	92143-1968	Buje	1
92200	92200-0851	Arandela	1
92200A	92200-1389	Arandela	4
600	600A0500	Balín 5/32	3

B-13 SELECTOR DE CAMBIOS

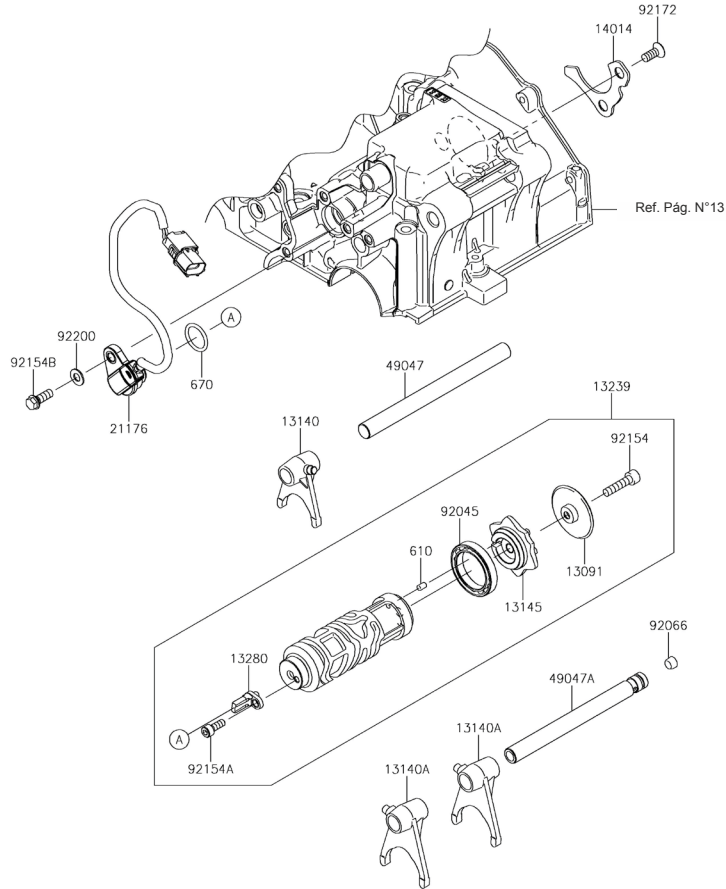

Fig N°	Parte No.	Descripción	18
			CJF
13091	13091-1464	Arandela Selector Cambios	1
13140	13140-1148	Horquilla Cambios	1
13140A	13140-1149	Horquilla Cambios	2
13145	13145-0556	Estrella Selector Cambios	1
13239	13239-0048	Eje Selector Cambios	1
13280	13280-0882	SopORTE Sensor Posición	1
14014	14014-0564	Platina	1
21176	21176-0832	Sensor Posición	1
49047	49047-0625	Pasador Horquilla Cambios	1
49047A	49047-0626	Pasador Horquilla Cambios	1
92045	92045-0826	Rodamiento Bolas 6806	1
92066	92066-1246	Tapón Drenaje Aceite	1
92154	92154-0954	Tornillo 6X25	1
92154A	92154-2559	Tornillo 5x14	1
92154B	92154-2561	Tornillo 6x16	1
92172	92172-0812	Tornillo 6x15	2
92200	92200-1857	Arandela 6.5x13x1	1
610	610A0406	Pin Eje Selector 4x6	1
670	670D2018	Anillo Retenedor 18 mm.	1

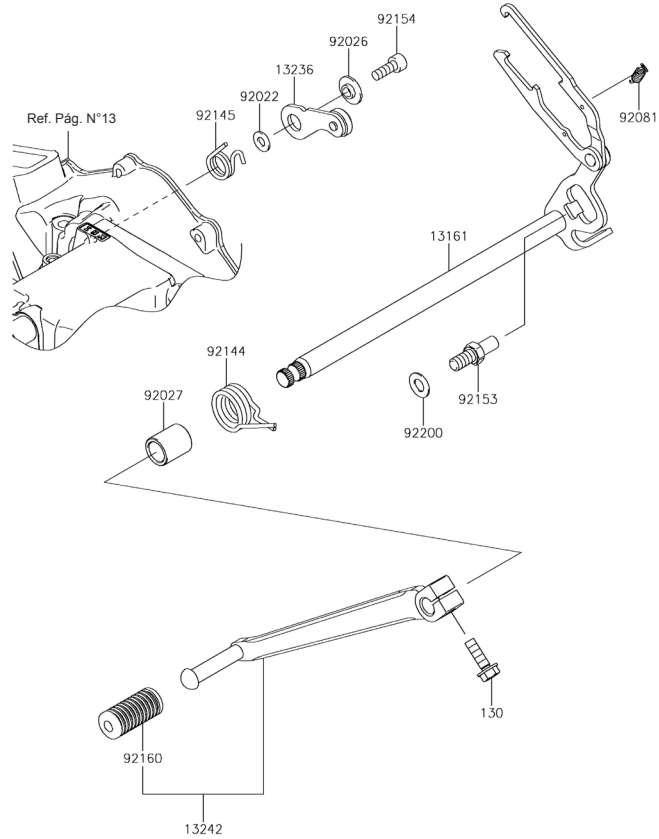

Fig N°	Parte No.	Descripción	18
			CJF
13161	13161-0560	Eje Cambios Completo	1
13236	13236-0797	Leva Eje Cambios	1
13242	13242-0151	Pedal de Cambios	1
92022	92022-1827	Arandela 6x12.8x1.2	1
92026	92026-1217	Separador	1
92027	92027-1440	Buje 13x18.3x21.5	1
92081	92081-076	Resorte Leva Cambios	1
92144	92144-1074	Resorte Retorno Pedal Cambios	1
92145	92145-1747	Resorte	1
92153	92153-1986	Tornillo 8x15.5	1
92154	92154-0235	Tornillo 6x16	1
92160	92160-1036	Caucho Pedal Cambios	1
92200	92200-0434	Arandela 8.2x16x1	1
130	130CC0620	Tornillo 6x20	1

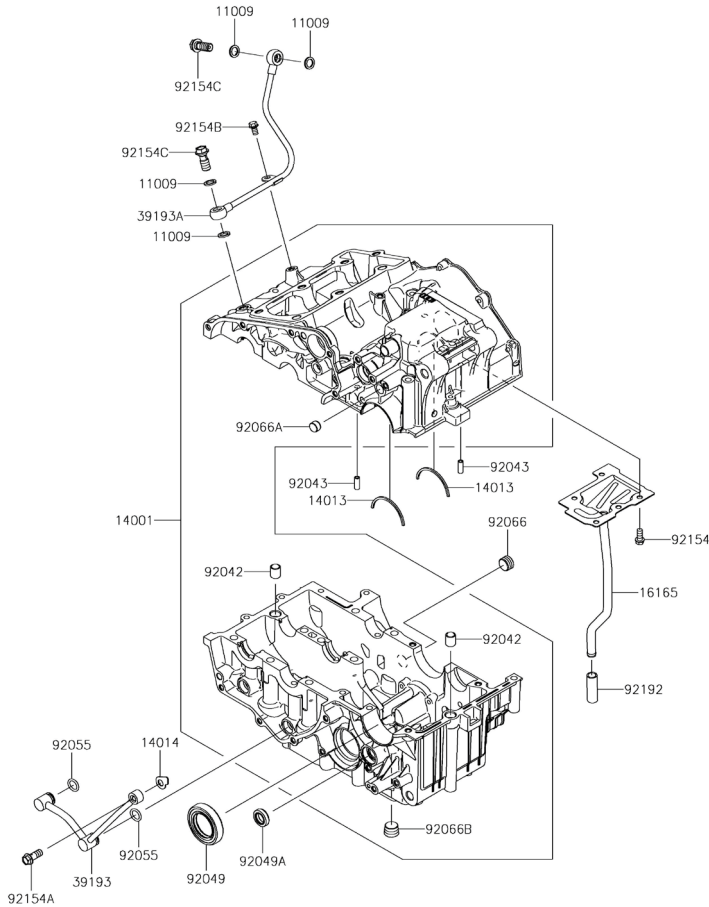

Fig N°	Parte No.	Descripción	18
			CJF
11009	11009-1105	Arandela Sellado 10x14.5x1.5	4
14001	14001-0688	Juego Carcasas	1
14013	14013-004	Pin Seguridad	2
14014	14014-0565	Platina	1
16165	16165-0013	Separador	1
39193	39193-0571	Conducto de Lubricación	1
39193A	39193-0583	Conducto de Lubricación	1
92042	92042-031	Pin Guía 12x14	2
92043	92043-1309	Pin 3.5x6x16	2
92049	92049-0731	Reten 32x52x10	1
92049A	92049-1559	Sello Aceite	1
92055	92055-0733	Anillo Retenedor 11.8x2.4	2
92066	92066-0003	Tapón Carcasa 3/8X10	1
92066A	92066-1110	Tapón	1
92066B	92066-1252	Tapón	1
92154	92154-0777	Tornillo 6x14	5
92154A	92154-0957	Tornillo 8x20	1
92154B	92154-2343	Tornillo 6x10	1
92154C	92154-2560	Tornillo 10x23	2
92192	92192-0225	Conducto 9x12x38	1

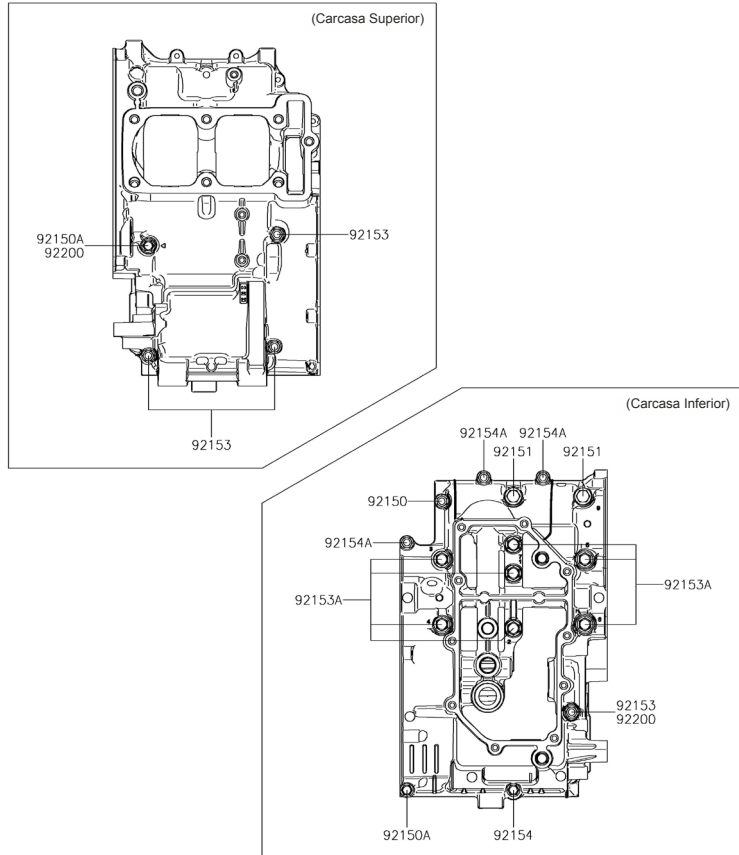

Fig N°	Parte No.	Descripción	18
			CJF
92150	92150-1301	Tornillo 6x38	1
92150A	92150-1548	Tornillo 6x60	2
92151	92151-1462	Tornillo 8x73	2
92153	92153-0927	Tornillo 6x85	4
92153A	92153-1632	Tornillo 8x90	7
92154	92154-1189	Tornillo 6x135	1
92154A	92154-2832	Tornillo 6x22	3
92200	92200-0788	Arandela 6.3x13.5x1	2

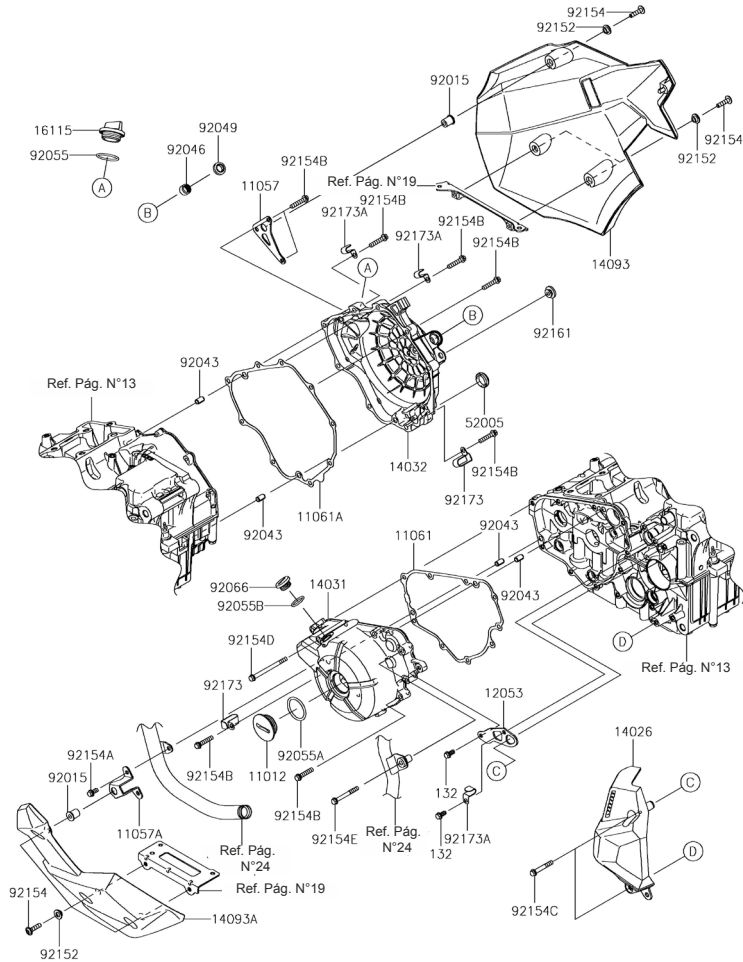

Fig N°	Parte No.	Descripción	18
			CJF
11012	11012-1362	Tapón Cubierta Volante	1
11057	11057-0623	Soporte Cubierta Inferior Derecha	1
11057A	11057-0674	Soporte Cubierta Inferior Izquierda	1
11061	11061-0793	Empaque Cubierta Volante	1
11061A	11061-0854	Empaque Cubierta Clutch	1
12053	12053-0237	Platina Guía	1
14026	14026-0133	Cubierta Cadena	1
14031	14031-0562	Cubierta Volante	1
14032	14032-0633	Cubierta Clutch	1
14093	14093-0548	Cubierta Inferior Derecha	1
14093A	14093-0549	Cubierta Inferior Izquierda	1
16115	16115-1068	Tapón Aceite	1
52005	52005-1009	Mirilla Nivel Aceite	1
92015	92015-1700	Tuerca	2
92043	92043-1263	Pin Guía 6.2x8x14	4
92046	92046-0034	Rodamiento Agujas	1
92049	92049-1560	Retenedor	1
92055	92055-049	Anillo Retenedor 31.5x2.6	1
92055A	92055-0734	Anillo Retenedor 39.4x3.1	1
92055B	92055-1146	Anillo Retenedor 20x2	1
92066	92066-0748	Tapón Aceite	1
92152	92152-2296	Buje	6
92154	92154-0071	Tornillo 6x25	6
92154A	92154-1140	Tornillo 6x12	2
92154B	92154-1773	Tornillo 6x30	16
92154C	92154-1774	Tornillo 6x40	2
92154D	92154-2346	Tornillo 6x75	1
92154E	92154-2347	Tornillo 6x50	1
92161	92161-1810	Antivibrante	1
92173	92173-0833	Abrazadera	2
92173A	92173-1811	Abrazadera	3
132	132BA0612	Tornillo 6x12	2

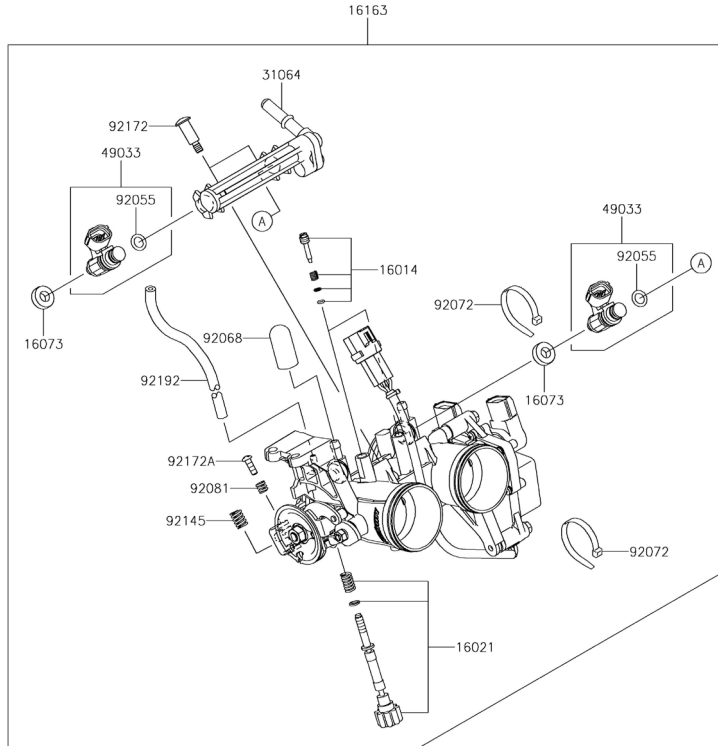

Fig N°	Parte No.	Descripción	18
			CJF
16014	16014-0002	Tornillo Aire	2
16021	16021-0027	Tornillo de Aceleración	1
16073	16073-0129	Empaque	2
16163	16163-0840	Cuerpo Inyección Completo	1
31064	31064-0164	Manguera Gasolina	1
49033	49033-0558	Inyector	2
92055	92055-0124	Anillo Retenedor	2
92068	92068-006	Tapón 12x25	2
92072	92072-0012	Abrazadera	2
92081	92081-1620	Resorte Acelerador	1
92145	92145-0656	Resorte Acelerador	1
92172	92172-0064	Tornillo	2
92172A	92172-0129	Tornillo	1
92192	92192-1170	Conducto 3x7x200	1

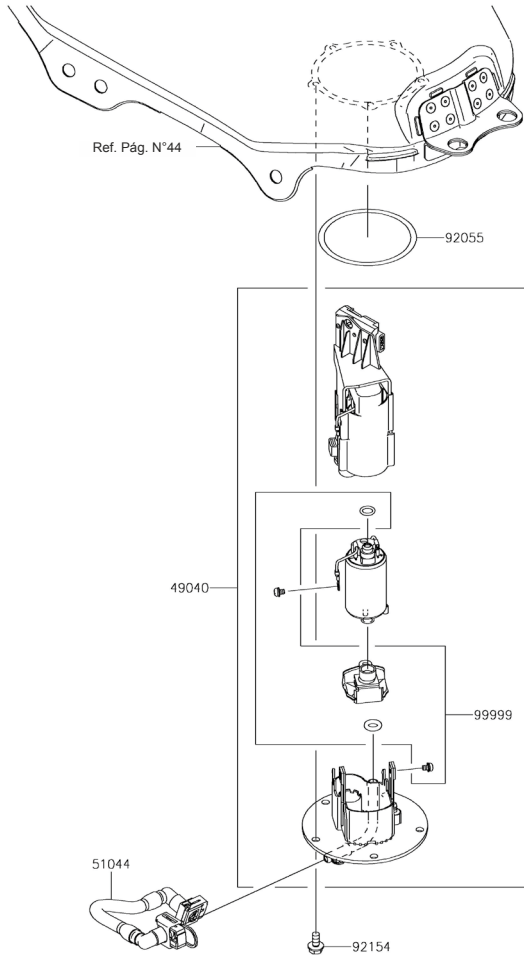

Fig N°	Parte No.	Descripción	18
			CJF
49040	49040-0758	Bomba de Gasolina	1
51044	51044-0853	Conducto Bomba Gasolina	1
92055	92055-0728	Anillo Retenedor 74.6x5.7	1
92154	92154-2335	Tornillo 6x12	5
99999	99999-0524	Kit Filtro Combustible	1

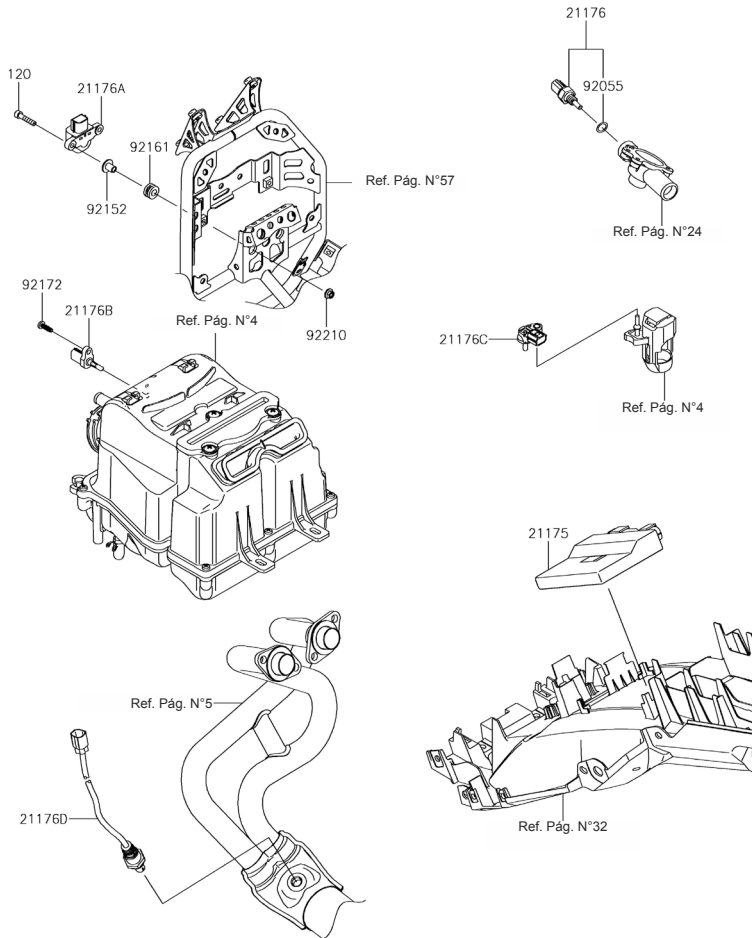

Fig N°	Parte No.	Descripción	18
			CJF
21175	21175-1256	E.C.U.	1
21176	21176-0009	Sensor Temperatura Agua	1
21176A	21176-0026	Sensor de Caída	1
21176B	21176-0048	Sensor Temperatura Aire	1
21176C	21176-0111	Sensor Presión	1
21176D	21176-0839	Sensor Oxígeno	1
92055	92055-0016	Anillo Retenedor 9.5x11.9	1
92152	92152-1562	Buje 5.6x8x11.2	2
92161	92161-0685	Antivibrante 8x16x8.6	2
92172	92172-0790	Tornillo 5x16	1
92210	92210-0007	Tuerca 5 mm.	2
120	120CA0525	Tornillo 5x25	2

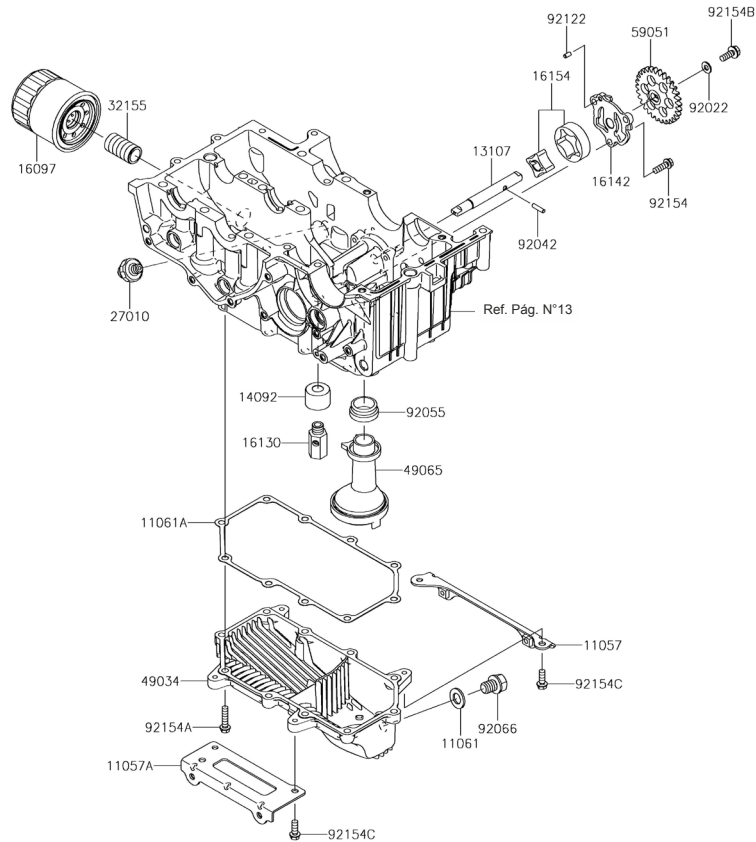

Fig N°	Parte No.	Descripción	18
			CJF
11057	11057-0541	Soporte Derecho	1
11057A	11057-0542	Soporte Izquierdo	1
11061	11061-0417	Arandela Sellado 12x22x2	1
11061A	11061-0794	Empaque Carter Aceite	1
13107	13107-0741	Eje Bomba Aceite	1
14092	14092-1002	Cubierta Válvula	1
16097	16097-0008	Filtro Aceite	1
16130	16130-0002	Válvula Carcasa Motor	1
16142	16142-0707	Cubierta Bomba Aceite	1
16154	16154-0711	Rotor Bomba Aceite	1
27010	27010-1313	Swiche Presión Aceite	1
32155	32155-0029	Conducto Filtro Aceite	1
49034	49034-0567	Carter Aceite	1
49065	49065-0711	Filtro Aceite	1
59051	59051-0721	Piñon Bomba Aceite 30T	1
92022	92022-1827	Arandela 6x12.8x1.2	1
92042	92042-014	Pin 4x15.8	1
92055	92055-1354	Empaque Filtro de Aceite	1
92066	92066-0767	Tapón Drenaje Aceite 12x15	1
92122	92122-0557	Pin 4x8	1
92154	92154-0784	Tornillo 6x18	3
92154A	92154-0819	Tornillo 6x25	10
92154B	92154-1055	Tornillo 6x16	1
92154C	92154-2561	Tornillo 6x16	4

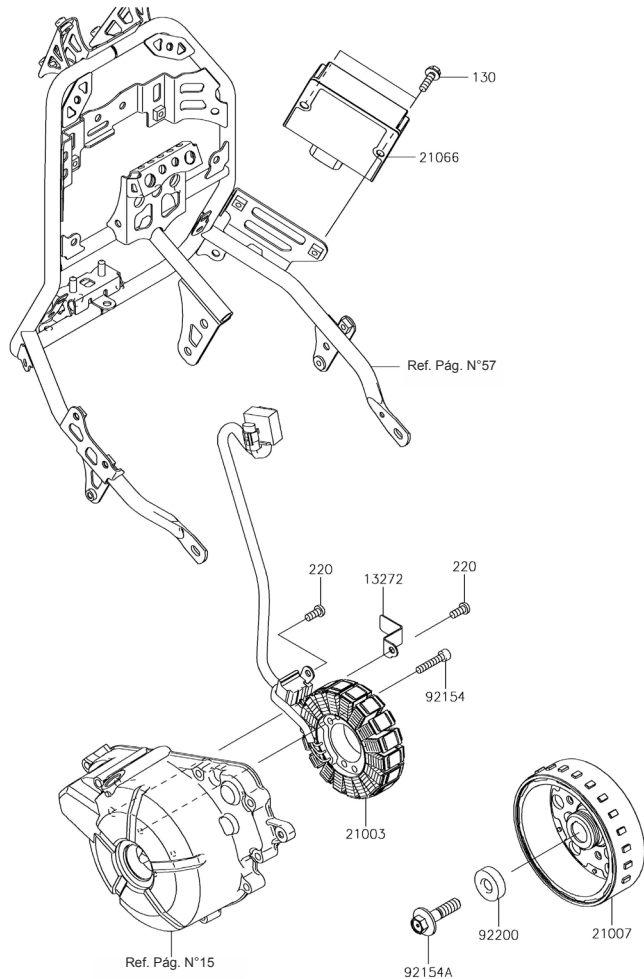
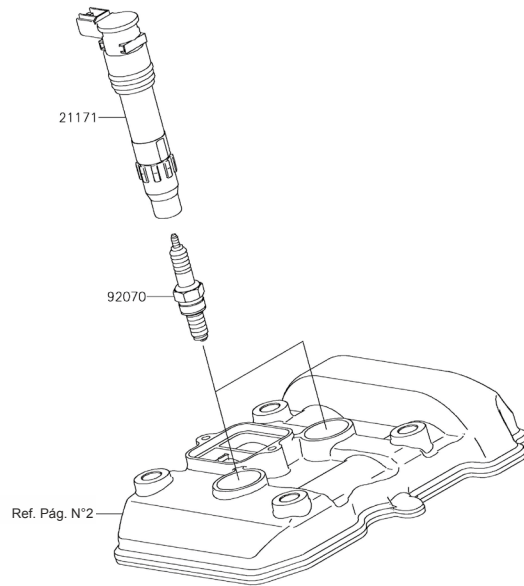

Fig N°	Parte No.	Descripción	18
			CJF
13272	13272-1257	Platina	1
21003	21003-0175	Plato Bobinas	1
21007	21007-0569	Volante	1
21066	21066-0753	Regulador	1
92154	92154-0962	Tornillo 6x30	3
92154A	92154-2341	Tornillo 10x40	1
92200	92200-0790	Arandela 10x30x9	1
130	130BA0620	Tornillo 6x20	2
220	220AA0614	Tornillo 6x14	2

Fig N°	Parte No.	Descripción	18
			CJF
21171	21171-0033	Bobina de Encendido	2
92070	92070-0031	Bujía CR8E (NGK)	2



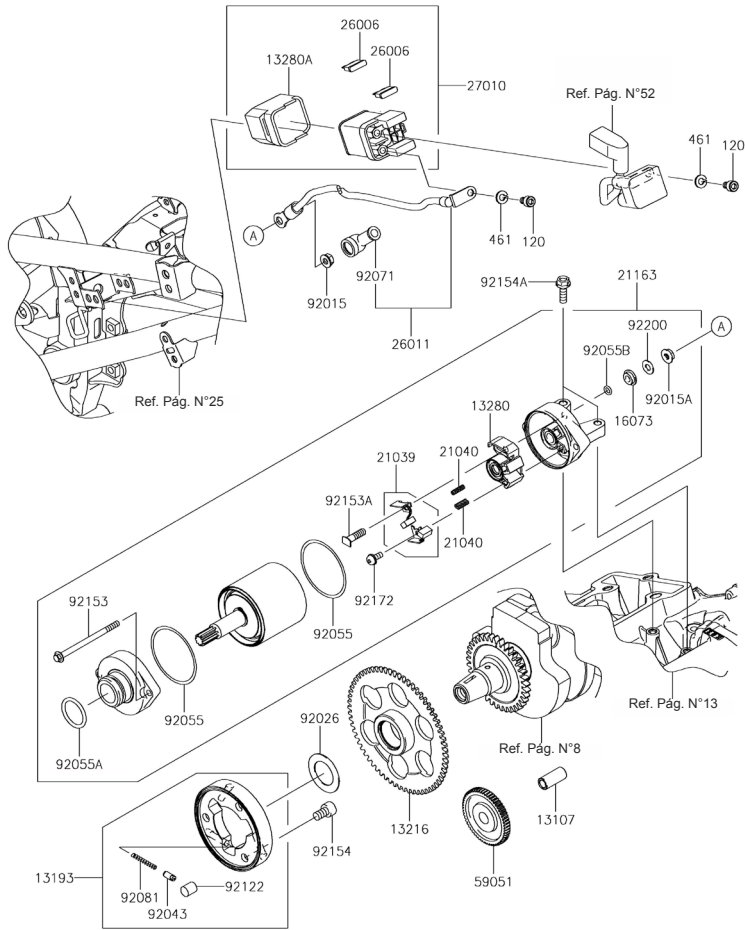

Fig N°	Parte No.	Descripción	18
			CJF
13107	13107-0743	Buje Piñón 8x12x26.5	1
13193	13193-1002	Clutch de Una Vía Completo	1
13216	13216-0880	Piñón Clutch de Una Vía 65T	1
13280	13280-0261	Soporte Motor Arranque	1
13280A	13280-0301	Protector Swiche Magnético	1
16073	16073-0053	Antivibrante	1
21039	21039-0005	Juego de Escobillas	1
21040	21040-0003	Resorte Escobillas	2
21163	21163-0717	Motor de Arranque	1
26006	26006-1006	Fusible 30A	2
26011	26011-0958	Cable Encendido	1
27010	27010-0099	Swiche Magnético	1
59051	59051-0722	Piñón Motor de Arranque	1
92015	92015-1367	Tuerca 6 mm.	1
92015A	92015-1476	Tuerca	1
92026	92026-0153	Arandela 25.2x40x1.0	1
92043	92043-132	Pin	3
92055	92055-0136	Anillo Retenedor	2
92055A	92055-1276	Anillo Retenedor	1
92055B	92055-1370	Anillo Retenedor 4.5x2.0	1
92071	92071-0705	Capuchón Cable Encendido	1
92081	92081-159	Resorte	3
92122	92122-006	Pin Clutch de Una Vía	3
92153	92153-1851	Tornillo	2
92153A	92153-1866	Tornillo	1
92154	92154-0175	Tornillo 8x13	3
92154A	92154-0786	Tornillo 6x20	2
92172	92172-0334	Tornillo	1
92200	92200-0386	Arandela	1
120	120CB0610	Tornillo 6x10	2
461	461DA0600	Arandela 6 mm.	2

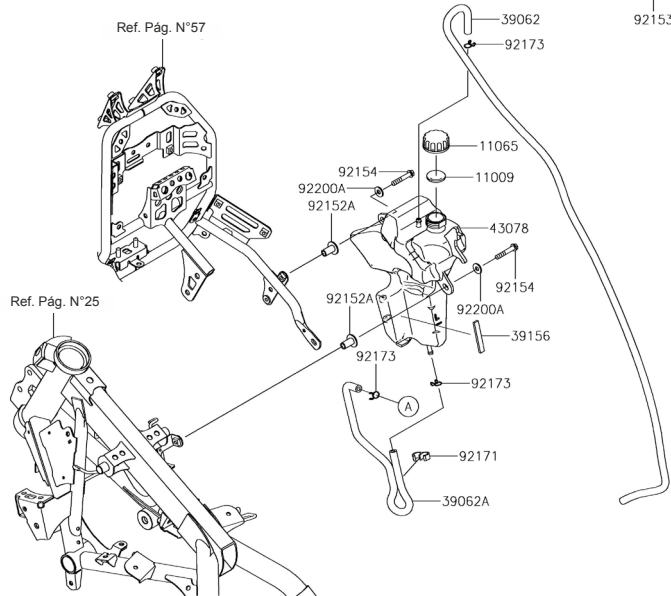
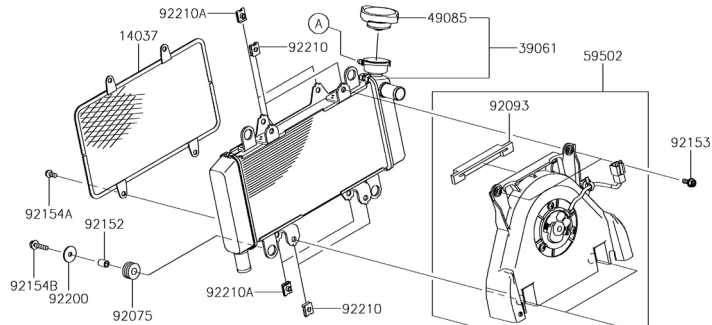

Fig N°	Parte No.	Descripción	18
			CJF
11009	11009-1145	Empaque Tapa Tanque Reserva	1
11065	11065-0969	Tapa Tanque Reserva	1
14037	14037-0781	Rejilla Radiador	1
39061	39061-0735	Radiador	1
39062	39062-0769	Manguera de Enfriamiento	1
39062A	39062-0770	Manguera Radiador	1
39156	39156-2198	Adhesivo 8x50x3	1
43078	43078-0587	Tanque de Reserva	1
49085	49085-0006	Tapa Radiador	1
59502	59502-0611	Ventilador Completo	1
92075	92075-1690	Antivibrante 10x24x12	4
92093	92093-0587	Protector Ventilador	1
92152	92152-0846	Buje 6.8x10x13	4
92152A	92152-2283	Buje	2
92153	92153-0531	Tornillo	4
92154	92154-0807	Tornillo 6x35	2
92154A	92154-1777	Tornillo 6x12	4
92154B	92154-2556	Tornillo 6x25	4
92171	92171-1184	Abrazadera	1
92173	92173-0050	Abrazadera	3
92200	92200-0789	Arandela 6.5x24x1.6	4
92200A	92200-1853	Arandela 6.5x16x1.6	2
92210	92210-1323	Tuerca	4
92210A	92210-1518	Tuerca	4

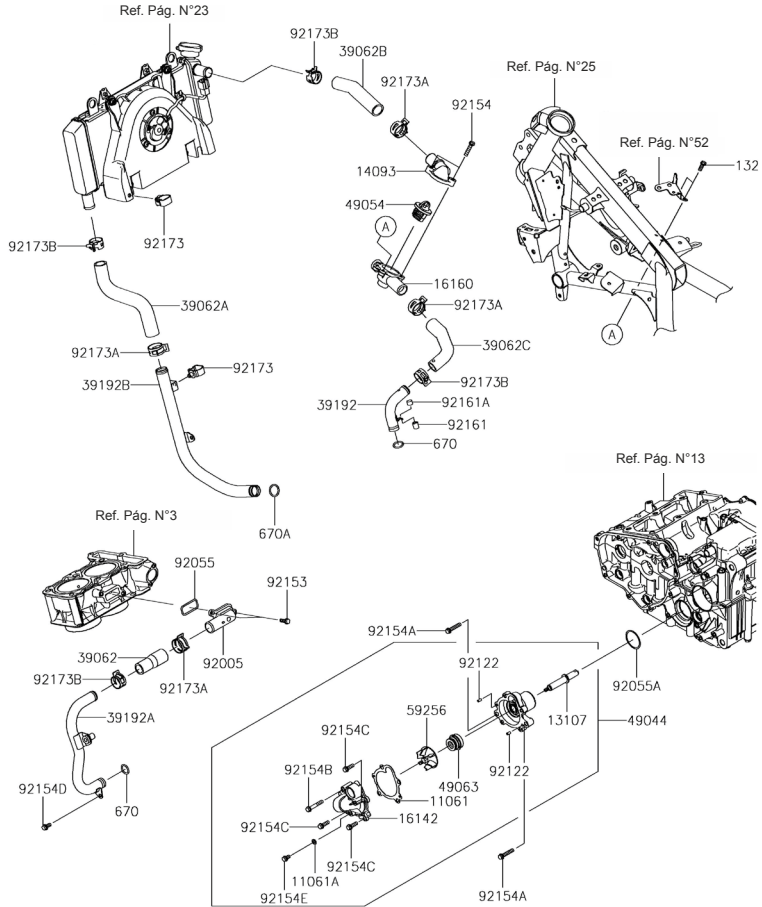

Fig N°	Parte No.	Descripción	18
			CJF
11061	11061-0795	Empaque Bomba Agua	1
11061A	11061-0875	Arandela Tornillo Drenaje	1
13107	13107-0742	Eje Bomba Agua	1
14093	14093-0224	Cubierta Termostato	1
16142	16142-0708	Cubierta Bomba Agua	1
16160	16160-0762	Cubierta Inferior Termostato	1
39062	39062-0693	Manguera Bomba Agua-Cilindro	1
39062A	39062-0773	Manguera Radiador-Bomba Agua	1
39062B	39062-0793	Manguera Radiador-Termostato	1
39062C	39062-0794	Manguera Culata-Termostato	1
39192	39192-0590	Conducto Culata-Termostato	1
39192A	39192-0600	Conducto Bomba Agua-Cilindro	1
39192B	39192-0604	Conducto Radiador-Bomba Agua	1
49044	49044-0015	Bomba de Agua Completa	1
49054	49054-1056	Termostato	1
49063	49063-1055	Retén Mecánico Bomba de Agua	1
59256	59256-0554	Turbina Bomba de Agua	1
92005	92005-0777	Conector Cilindro	1
92055	92055-0735	Anillo Retenedor 2.4 mm.	1
92055A	92055-0736	Anillo Retenedor 34.4x3.1	1
92122	92122-0557	Pin 4x8	2
92153	92153-0695	Tornillo 6x16	2
92154	92154-1212	Tornillo 6x25	2
92154A	92154-1773	Tornillo 6x30	2
92154B	92154-1779	Tornillo 6x35	1
92154C	92154-2349	Tornillo 6x18	3
92154D	92154-2351	Tornillo 6x12	1
92154E	92154-2557	Tornillo 6x10	1
92161	92161-0690	Antivibrante 10x11.5	1
92161A	92161-0691	Antivibrante 10x7.5	1
92173	92173-0861	Abrazadera	2
92173A	92173-1416	Abrazadera	4
92173B	92173-1417	Abrazadera	4
132	132BA0614	Tornillo 6x14	2
670	670B2016	Anillo Retenedor 16 mm.	2
670A	670B2018	Anillo Retenedor 18 mm.	1

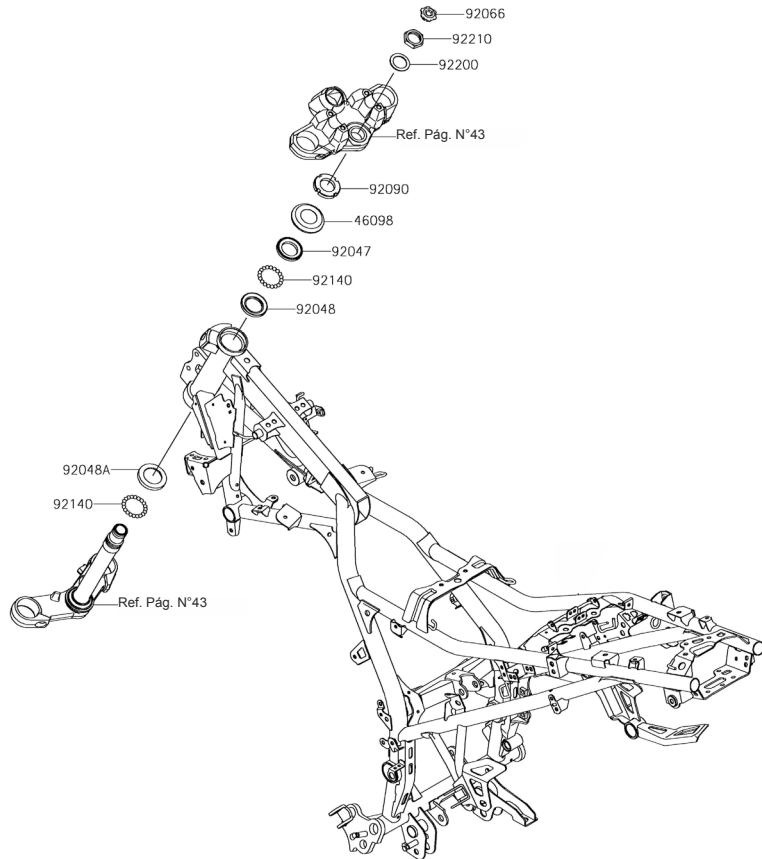

Fig N°	Parte No.	Descripción	18
			CJF
46098	46098-016	Guardapolvo Columna Dirección	1
92047	92047-011	Cuna Dirección	1
92048	92048-006	Cuna Dirección	1
92048A	92048-008	Cuna Dirección	1
92066	92066-0785	Tapón Espiga Dirección	1
92090	92090-007	Tuerca 30 mm.	1
92140	92140-0008	Balín 6.35 mm.	39
92200	92200-1858	Arandela 25.5x36x1.6	1
92210	92210-0858	Tuerca 25 mm.	1

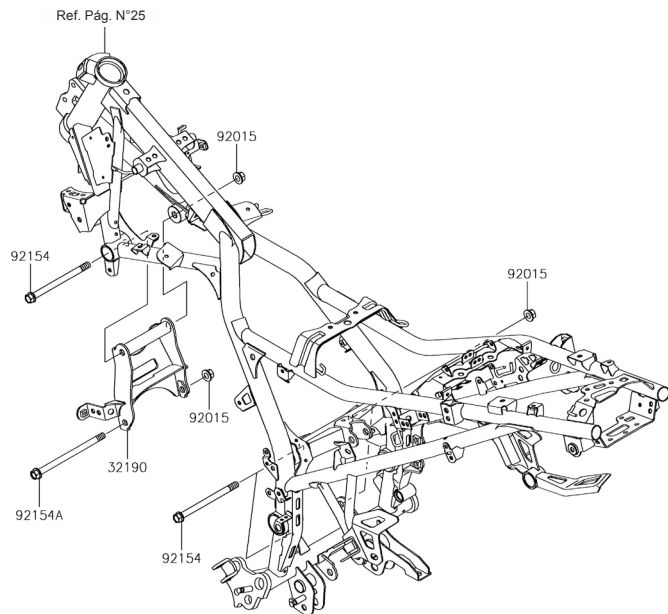

Fig N°	Parte No.	Descripción	18
			CJF
32190	32190-0740	Soporte Motor	1
92015	92015-1415	Tuerca 10 mm.	4
92154	92154-0359	Tornillo 10x135	3
92154A	92154-2509	Tornillo	1

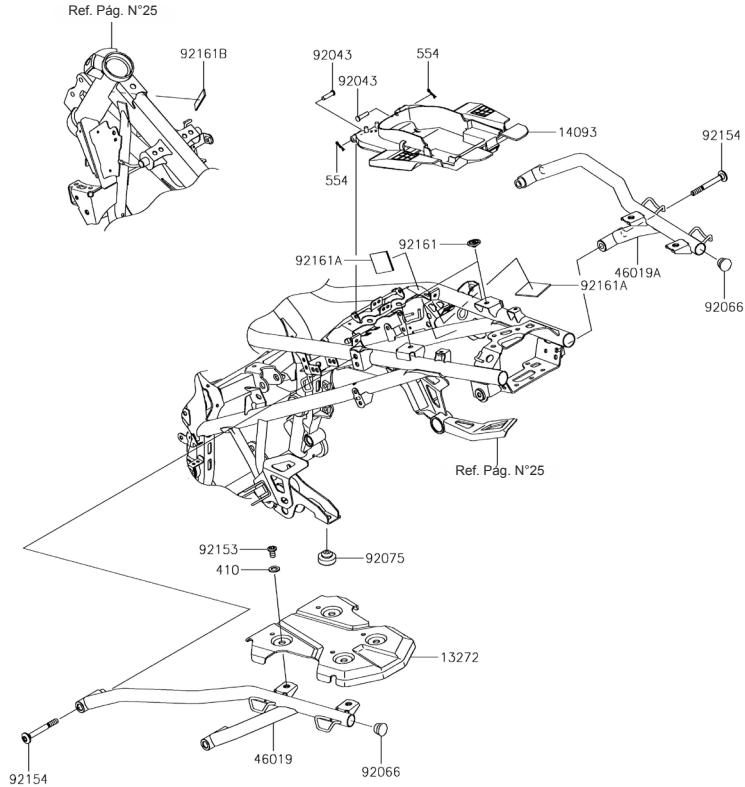

Fig N°	Parte No.	Descripción	18
			CJF
13272	13272-2247	Base Agarradera Trasera	1
14093	14093-0557	Cubierta Estuche Herramienta	1
46019	46019-0070-18R	Agarradera Chasis Izquierda Negra	1
46019A	46019-0071-18R	Agarradera Chasis Derecha Negra	1
92043	92043-0746	Pin 6x23	2
92066	92066-1220	Tapón Chasis	2
92075	92075-1045	Antivibrante	1
92153	92153-1810	Tornillo 8x15	4
92154	92154-2339	Tornillo 8x73	4
92161	92161-1685	Antivibrante 8x22x10	2
92161A	92161-1883	Antivibrante	2
92161B	92161-1972	Antivibrante 13x48x2	1
410	410AA1000	Arandela 10 mm.	4
554	554DA0600	Pin 1.2x21.2	2

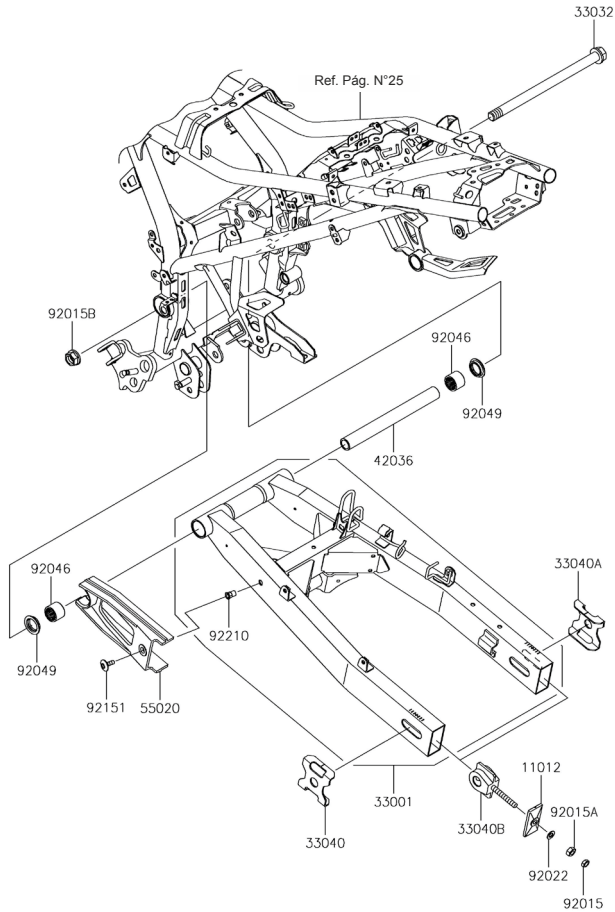

Fig N°	Parte No.	Descripción	18
			CJF
11012	11012-1871-18R	Platina Tensor Cadena	2
33001	33001-0684-18R	Brazo Oscilante	1
33032	33032-1134	Eje Brazo Oscilante	1
33040	33040-0030-18R	Platina Tensor Cadena	1
33040A	33040-0088-18R	Platina Tensor Cadena	1
33040B	33040-1116	Tensor Cadena	2
42036	42036-0816	Buje 16.1x22x213.8	1
55020	55020-0317	Protector Cadena	1
92015	92015-1364	Tuerca 8 mm.	2
92015A	92015-1658	Tuerca 8 mm.	2
92015B	92015-1946	Tuerca Eje Brazo Oscilante 16 mm.	1
92022	92022-1582	Arandela 8.5x16x1.2	2
92046	92046-0610	Rodamiento de Aguja 22x28x20	2
92049	92049-1254	Retenedor Brazo Oscilante 22-28-5.7	2
92151	92151-1149	Tornillo 6x18	1
92210	92210-1397	Tuerca 6 mm.	1

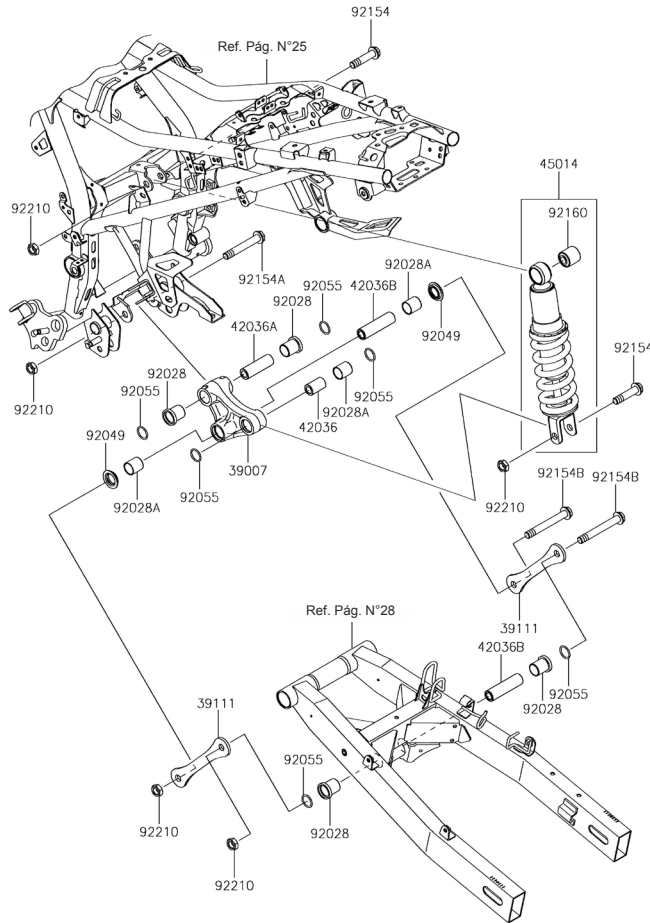

Fig N°	Parte No.	Descripción	18
			CJF
39007	39007-0407	Soporte Amortiguador	1
39111	39111-0349	Platina Soporte Amortiguador	2
42036	42036-1077	Buje 12.1x20x32	1
42036A	42036-1078	Buje Delantero	1
42036B	42036-1102	Buje 12.1x20x74	2
45014	45014-0580-37S	Amortiguador	1
92028	92028-1597	Buje	4
92028A	92028-1598	Buje	3
92049	92049-1109	Retenedor	2
92055	92055-0732	Anillo Retenedor 19.8x2.2	6
92154	92154-2510	Tornillo 12x51	2
92154A	92154-2511	Tornillo 12x79	1
92154B	92154-2512	Tornillo 12x93	2
92160	92160-1161	Buje Superior Amortiguador	1
92210	92210-1247	Tuerca 12 mm.	5

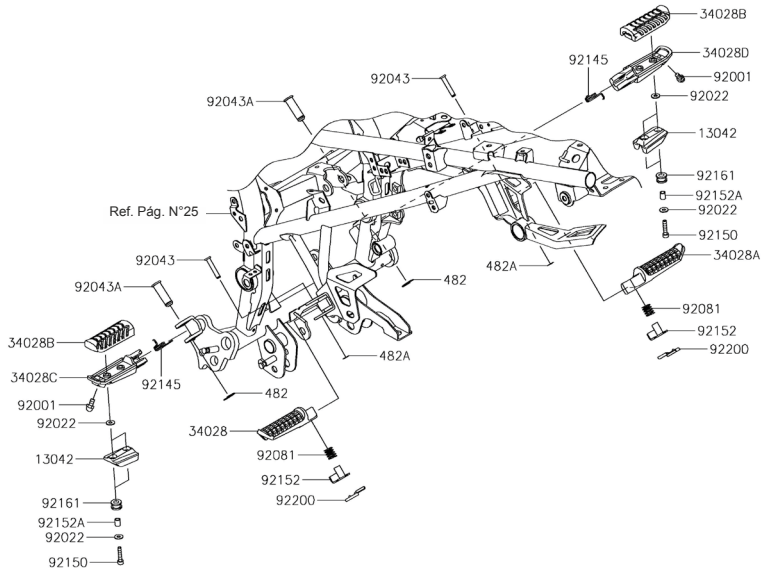

Fig N°	Parte No.	Descripción	18
			CJF
13042	13042-0759	Platina Reposapie Delantero	2
34028	34028-0334	Reposapie Trasero Izquierdo	1
34028A	34028-0335	Reposapie Trasero Derecho	1
34028B	34028-0349	Caucho Reposapie Delantero	2
34028C	34028-0350	Reposapie Delantero Izquierdo	1
34028D	34028-0351	Reposapie Delantero Derecho	1
92001	92001-1905	Tornillo Reposapie Delantero	2
92022	92022-1380	Arandela 5.2x13x1	8
92043	92043-0907	Pin Pasador 5x31.8	2
92043A	92043-0924	Pin Pasador 12x39	2
92081	92081-1612	Resorte Reposapie Trasero	2
92145	92145-0723	Resorte Reposapie Delantero	2
92150	92150-1684	Tornillo 5x25	4
92152	92152-0658	Buje	2
92152A	92152-1545	Buje 5.6x8x10.5	4
92161	92161-1935	Antivibrante 8x16x10	4
92200	92200-1892	Arandela	2
482	482EA0100	Pin de Seguridad 10 mm.	2
482A	482EA5000	Pin de Seguridad 5 mm.	2

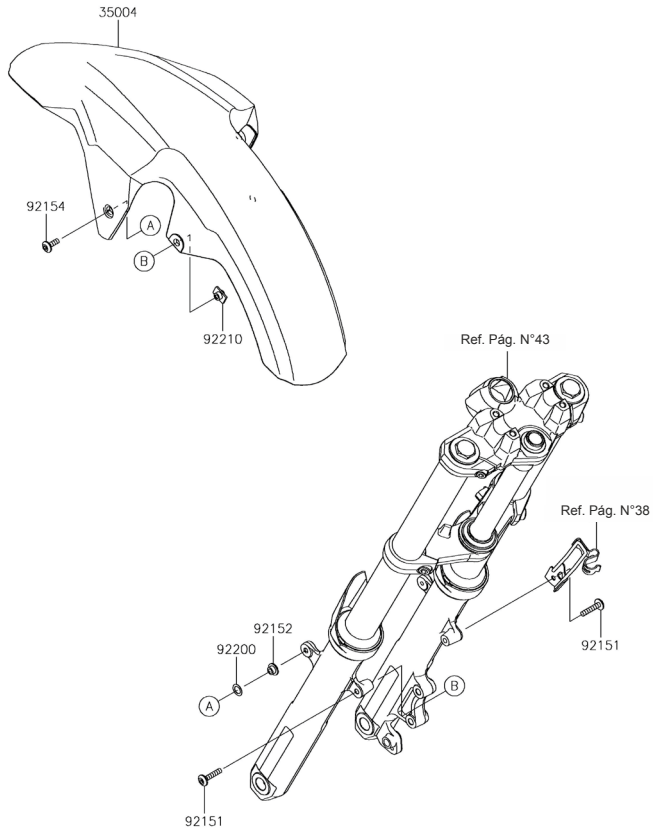

Fig N°	Parte No.	Descripción	18
			CJF
35004	35004-0363-45L	Guardabarro Delantero Negro	1
92151	92151-1605	Tornillo 6x30	2
92152	92152-234B	Buje 6.2x16x6.6	2
92154	92154-1291	Tornillo 6x18	2
92200	92200-0157	Arandela 10.4x15.9x0.5	2
92210	92210-1564	Tuerca 6 mm.	2

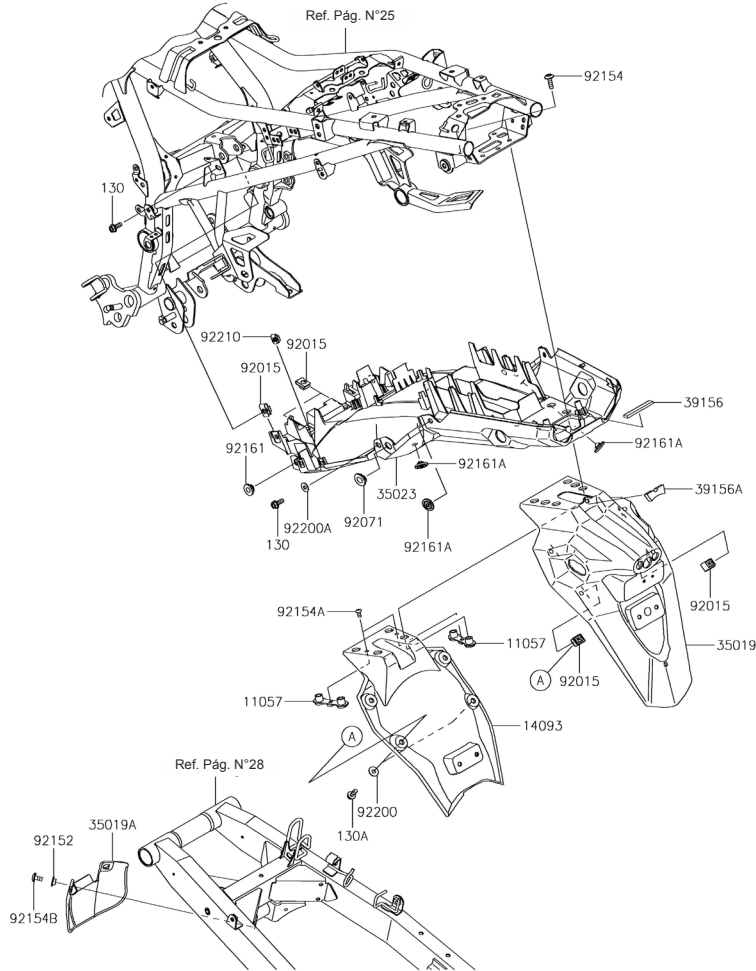
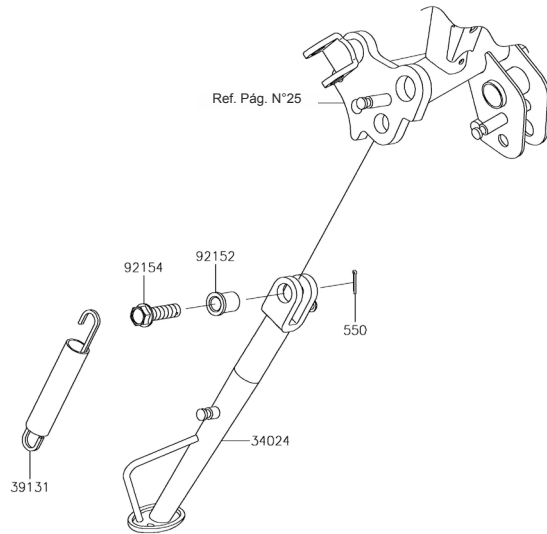

Fig N°	Parte No.	Descripción	18
			CJF
11057	11057-0556	Soporte Guardabarro Trasero Externo	2
14093	14093-0552	Cubierta Guardabarro Trasero Externo	1
35019	35019-0632	Guardabarro Trasero Externo	1
35019A	35019-0634	Protector Brazo Oscilante	1
35023	35023-0427	Guardabarro Trasero Interno	1
39156	39156-0820	Antivibrante 9x60x4	1
39156A	39156-2211	Antivibrante	1
92015	92015-1602	Tuerca 6 mm.	8
92071	92071-0766	Antivibrante 20x24x7.5	2
92152	92152-2296	Buje	2
92154	92154-0918	Tornillo 6x20	4
92154A	92154-1547	Tornillo 5x10	2
92154B	92154-2355	Tornillo 6x12	2
92161	92161-1531	Antivibrante	2
92161A	92161-1685	Antivibrante 8x22x10	4
92200	92200-0430	Arandela 6.5x17x1	4
92200A	92200-0796	Arandela 6.5x16x1.0	2
92210	92210-0817	Tuerca 5 mm.	2
130	130BA0616	Tornillo 6x16	4
130A	130BB0616	Tornillo 6x16	4

Fig N°	Parte No.	Descripción	18
			CJF

34024	34024-0144	Gato Lateral	1
39131	39131-0002	Resorte Gato Lateral	1
92152	92152-2299	Buje 10.2x18x20.1	1
92154	92154-1539	Tornillo 10x37	1
550	550AA2015	Pin 2.0x15	1



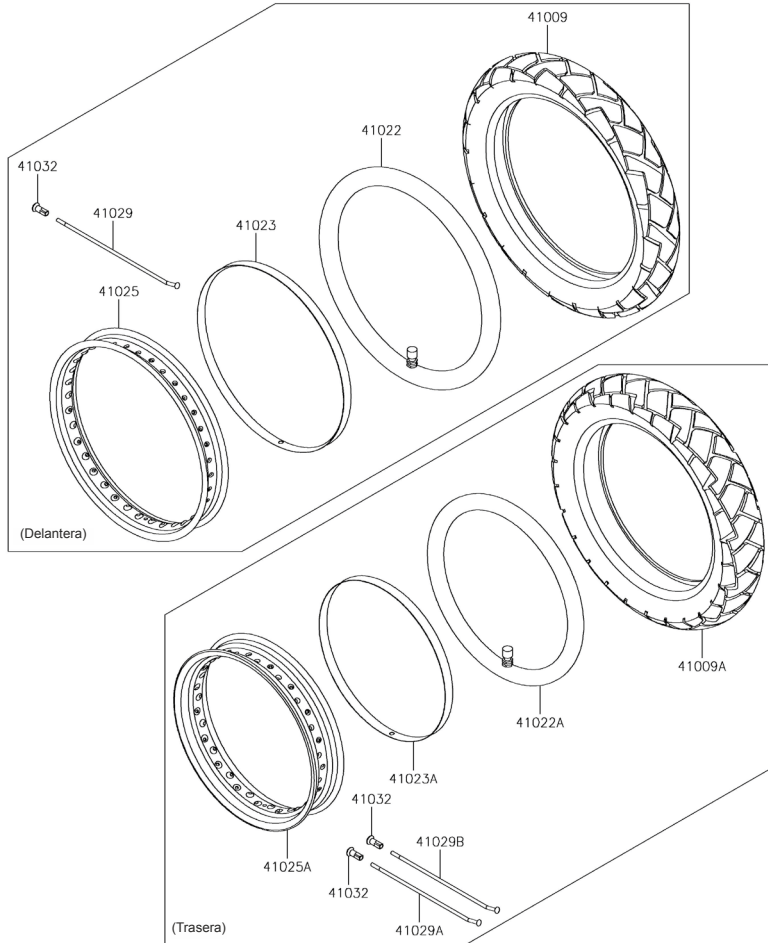

Fig N°	Parte No.	Descripción	18
			CJF
41009	100/90-19-GP210-TL	Llanta Del. 100/90-19 57S GP-210F	1
41009A	130/80-17-GP210-TL	Llanta Tras. 130/80-17 65S GP-210R	1
41022	41022-0084	Neumatico 100/90-19	1
41022A	41022-0085	Neumatico 130/80-17	1
41023	41023-0038	Protector Neumatico 25-19	1
41023A	41023-0039	Protector Neumatico 25-17	1
41025	41025-0373-WA	Rin Delantero 2.15x19	1
41025A	41025-0374-WA	Rin Trasero 3.00x17	1
41029	41029-0087	Radio Delantero Interno 196x164.5	36
41029A	41029-0088	Radio Trasero Interno 175x163.5	18
41029B	41029-0089	Radio Trasero Interno 172x159	18
41032	41032-0005	Cabeza Radio	72

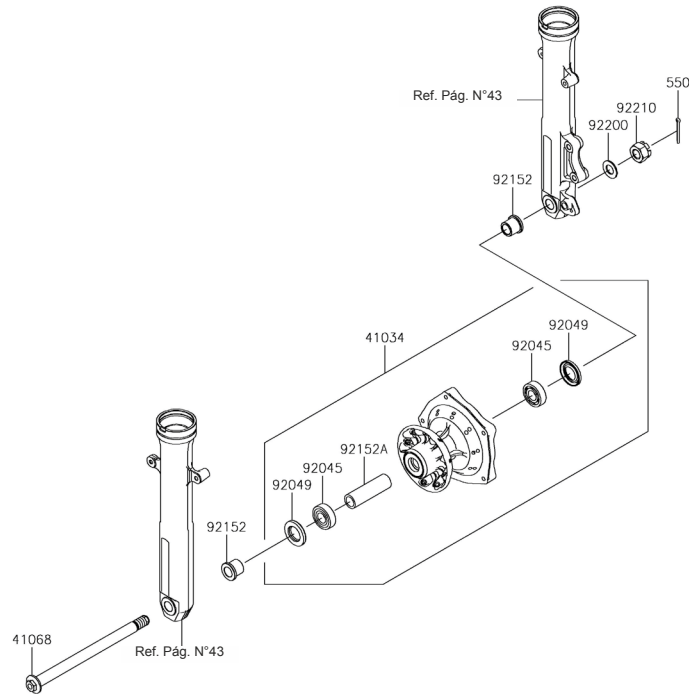

Fig N°	Parte No.	Descripción	18
			CJF
41034	41034-0587-458	Campana Delantera Completa	1
41068	41068-0623	Eje Rueda Delantera 17x249	1
92045	92045-0732	Rodamiento de Bolas 17x40x12	2
92049	92049-0794	Retenedor	2
92152	92152-2290	Buje 17x24x23	2
92152A	92152-2291	Buje	1
92200	92200-1842	Arandela 16.2x30x2.0	1
92210	92210-1171	Tuerca 16 mm.	1
550	550AA4035	Pin 4.0x35	1

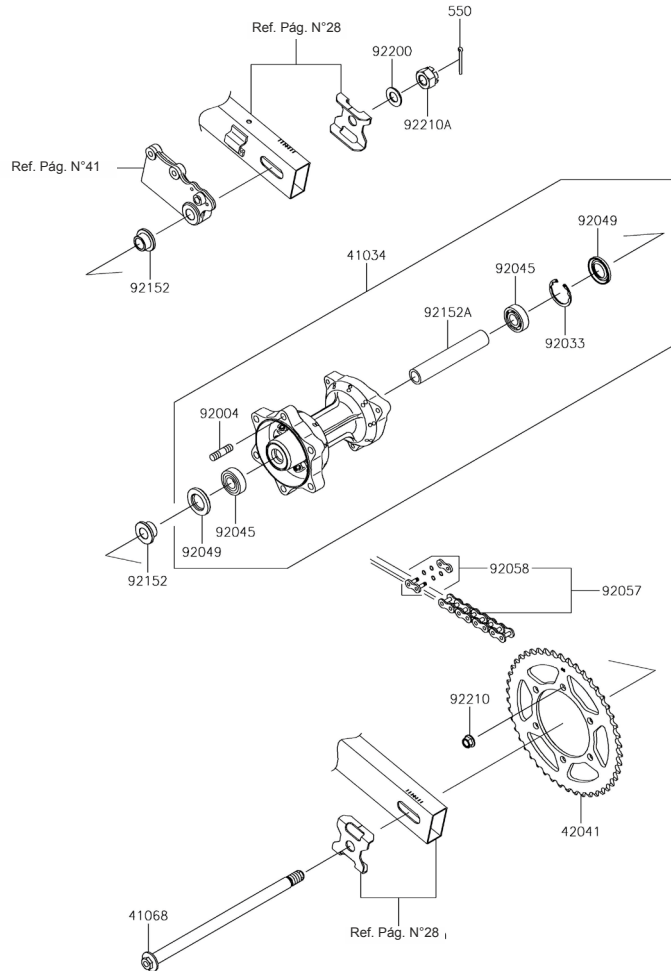

Fig N°	Parte No.	Descripción	18
			CJF
41034	41034-0588-458	Campana Trasera Completa	1
41068	41068-0624	Eje Rueda Trasera 17x312	1
42041	42041-0120	Sprocket 46T	1
92004	92004-0048	Esparrago 10x19	6
92033	92033-1040	Pin Seguridad 40 mm.	1
92045	92045-0732	Rodamiento de Bolas 17x40x12	2
92049	92049-0794	Retenedor	2
92057	92057-0647	Cadena EK520RMx112L	1
92058	92058-0037	Empate Cadena	1
92152	92152-2292	Buje 17x24x16	2
92152A	92152-2317	Buje 17.1x24x141	1
92200	92200-1842	Arandela 16.2x30x2.0	1
92210	92210-0276	Tuerca 10 mm.	6
92210A	92210-1171	Tuerca 16 mm.	1
550	550AA4035	Pin 4.0X35	1

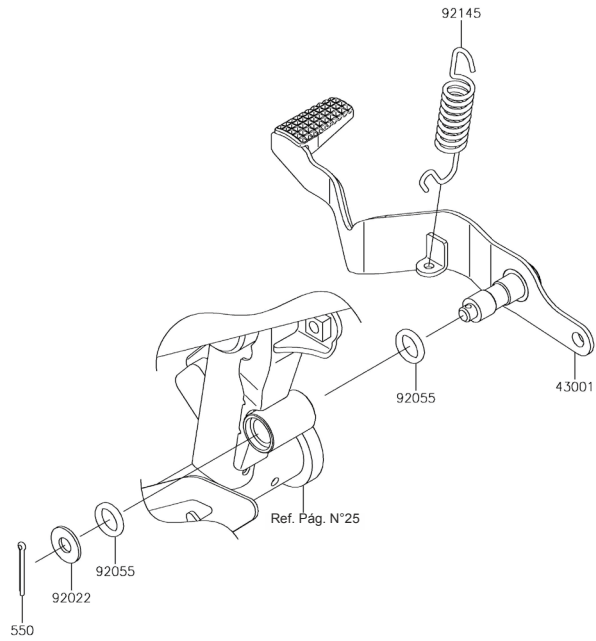

Fig N°	Parte No.	Descripción	18
			CJF
43001	43001-0750	Pedal Freno	1
92022	92022-1561	Arandela 8.5x20x1.6	1
92055	92055-0168	Anillo Retenedor 18.5 mm.	2
92145	92145-0230	Resorte Pedal Freno	1
550	550AA2525	Pin 2.5x25	1

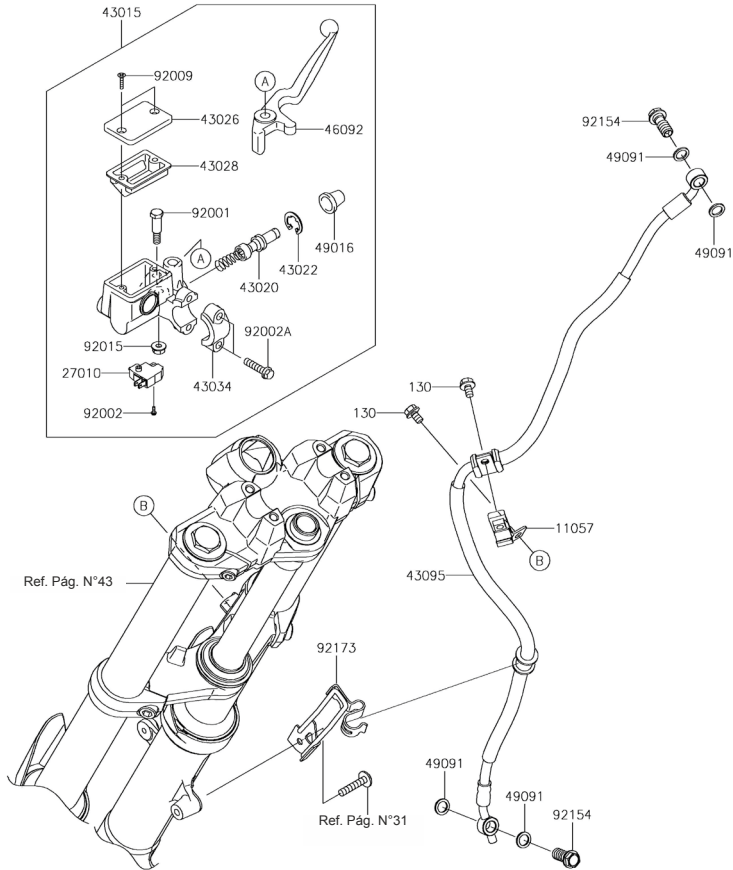

Fig N°	Parte No.	Descripción	18
			CJF
11057	11057-0629	Guía Manguera Freno Delantero	1
27010	27010-0762	Swiche Stop	1
43015	43015-0676	Bomba Freno Delantero	1
43020	43020-0022	Pistón Bomba Freno	1
43022	43022-1010	Pin Bomba Freno	1
43026	43026-1074	Tapa Bomba Freno	1
43028	43028-1061	Diafragma	1
43034	43034-1016	Abrazadera Bomba Freno	1
43095	43095-1445	Manguera Freno Delantero 916 mm.	1
46092	46092-1203	Leva Freno Delantero	1
49016	49016-1044	Guardapolvo	1
49091	49091-0001	Arandela Tornillo Aceite 10.1x14.5x1.5	4
92001	92001-1728	Tornillo Leva Freno	1
92002	92002-1323	Tornillo 4x12	1
92002A	92002-1894	Tornillo	2
92009	92009-1458	Tornillo Tapa Bomba Freno 4 mm.	2
92015	92015-1233	Tuerca 6 mm.	1
92154	92154-2560	Tornillo Manguera Freno 10x23	2
92173	92173-1654	Guía Manguera Freno Delantero	1
130	130BA0610	Tornillo 6x10	2

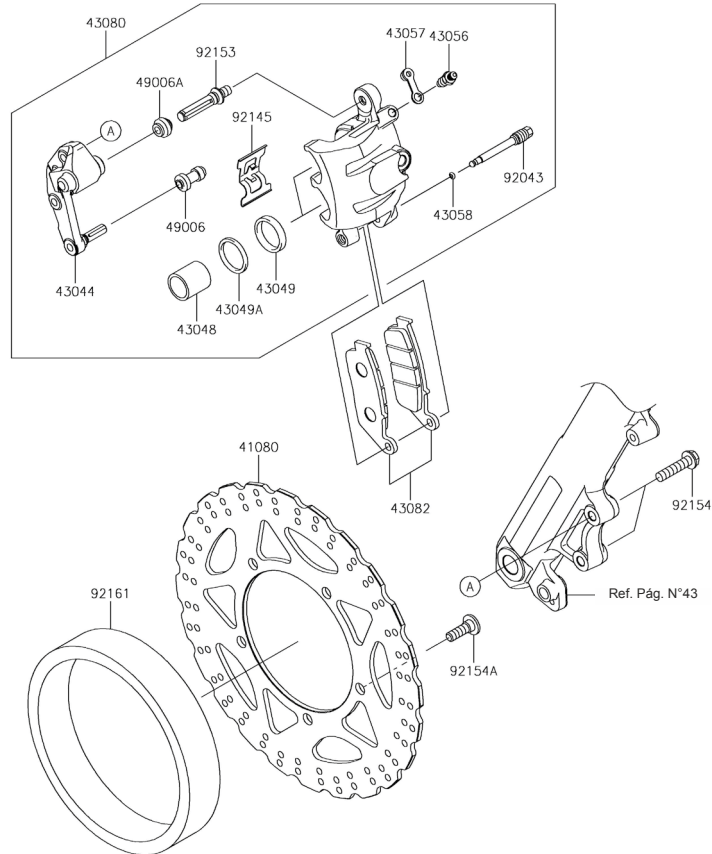

Fig N°	Parte No.	Descripción	18
			CJF
41080	41080-0672-11H	Disco de Freno Delantero Negro	1
43044	43044-0083	Soporte Caliper Delantero	1
43048	43048-0030	Pistón Caliper	2
43049	43049-1060	Empaque	2
43049A	43049-1061	Empaque	2
43056	43056-0004	Tornillo Sangrador Caliper	1
43057	43057-1001	Tapón	1
43058	43058-1100	Pin Seguridad	1
43080	43080-0180-DJ	Caliper Delantero Negro	1
43082	43082-0173	Pastas Freno Delantero	1
49006	49006-1088	Guardapolvo Caliper	1
49006A	49006-1242	Guardapolvo Caliper	1
92043	92043-0820	Pasador Caliper	1
92145	92145-0524	Resorte Pastas Freno	1
92153	92153-1872	Pasador Caliper	1
92154	92154-1646	Tornillo 8x35	2
92154A	92154-2534	Tornillo 8x26	5
92161	92161-1925	Protector Disco Freno Del. 168x192x36	1

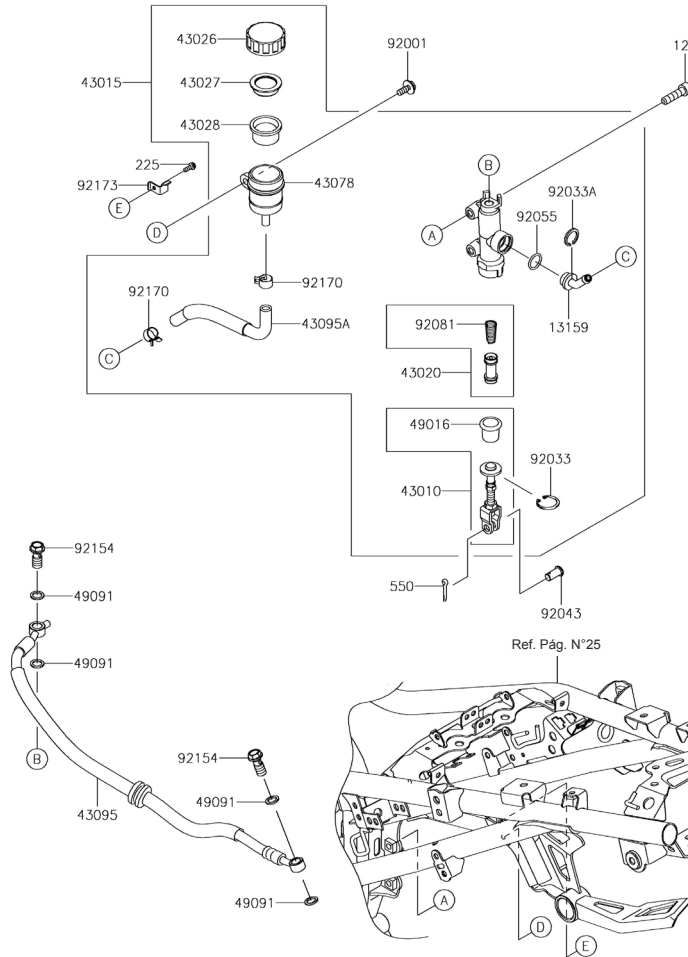

Fig N°	Parte No.	Descripción	18
			CJF
13159	13159-0008	Conector Cilindro Bomba Freno	1
43010	43010-0021	Unión Bomba Freno Trasero	1
43015	43015-0656	Bomba Freno Trasero	1
43020	43020-0023	Pistón Bomba Freno	1
43026	43026-0009	Tapa Bomba Freno Trasero	1
43027	43027-1053	Empaque Tapa Bomba Freno Trasero	1
43028	43028-1065	Diafragma Bomba Freno	1
43078	43078-0040	Tanque Líquido de Frenos	1
43095	43095-1446	Manguera Freno Trasero	1
43095A	43095-1449	Manguera Freno Trasero	1
49016	49016-1103	Acople Unión Bomba Freno	1
49091	49091-0001	Arandela Tornillo Aceite 10.1x14.5x1.5	4
92001	92001-1860	Tornillo 6x16	1
92033	92033-0079	Pin Seguridad 20.9x24.6x1.2	1
92033A	92033-1186	Pin Seguridad 20.5 mm.	1
92043	92043-0104	Pin Pasador 8x17	1
92055	92055-0741	Anillo Retenedor 14.8x2.4	1
92081	92081-1737	Resorte Bomba Freno	1
92154	92154-2560	Tornillo 10x23	2
92170	92170-1091	Abrazadera	2
92173	92173-0028	Abrazadera	1
120	120CA0830	Tornillo 8x30	2
225	225AB0412	Tornillo 4x12	1
550	550AA2015	Pin 2.0x15	1

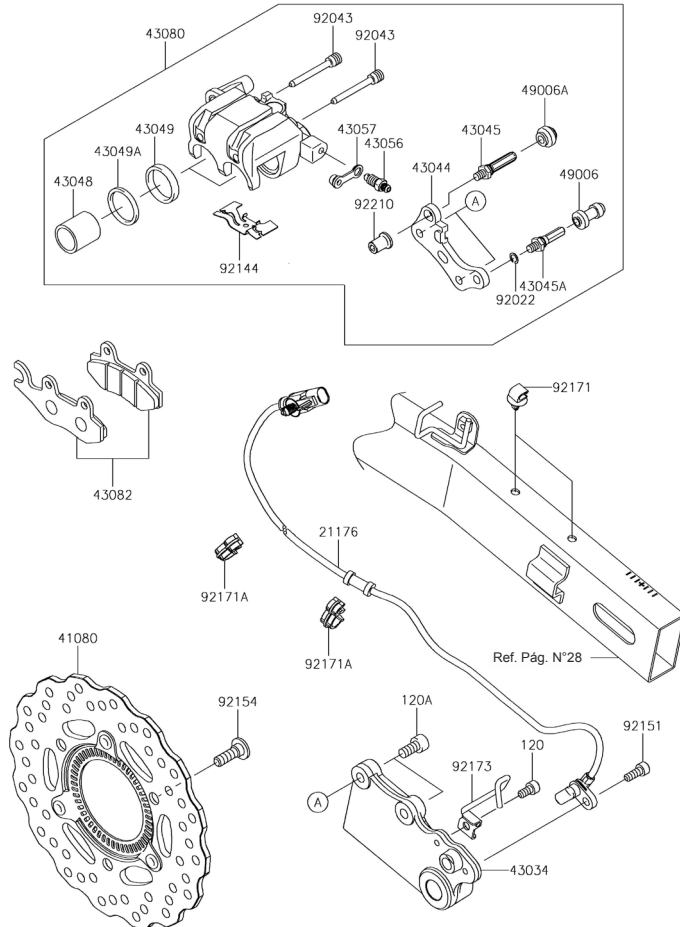

Fig N°	Parte No.	Descripción	18
			CJF
21176	21176-0843	Sensor de Velocidad	1
41080	41080-0671-11H	Disco de Freno Trasero	1
43034	43034-0135	Soporte Caliper Trasero	1
43044	43044-1112	Soporte Caliper	1
43045	43045-0004	Pasador Caliper	1
43045A	43045-1010	Pasador Caliper	1
43048	43048-1066	Pistón Caliper	2
43049	43049-1063	Empaque	2
43049A	43049-1064	Empaque	2
43056	43056-0004	Tornillo Sangrador Caliper	1
43057	43057-1001	Tapón	1
43080	43080-0126-DJ	Caliper Trasero Negro	1
43082	43082-0172	Pastas Freno Trasero	1
49006	49006-1088	Guardapolvo Caliper	1
49006A	49006-1242	Guardapolvo Caliper	1
92022	92022-1373	Pin Seguridad	1
92043	92043-1416	Pasador Caliper	2
92144	92144-1847	Resorte Pastas Freno	1
92151	92151-1166	Tornillo	1
92154	92154-2534	Tornillo 8x26	3
92171	92171-0640	Abrazadera	2
92171A	92171-1703	Abrazadera	2
92173	92173-1670	Guía Sensor Velocidad	1
92210	92210-0615	Tuerca	1
120	120CA0612	Tornillo 6X12	1
120A	120CA0816	Tornillo 8x16	2

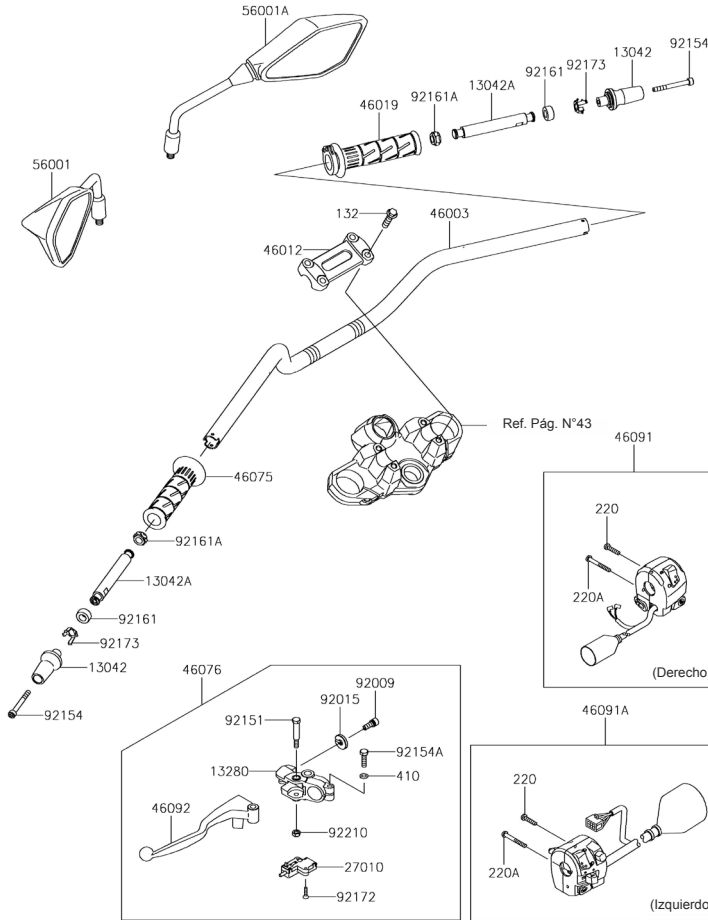

Fig N°	Parte No.	Descripción	18
			CJF
13042	13042-0742	Buje Manubrio Externo	2
13042A	13042-0761	Buje Manubrio Interno	2
13280	13280-0105	Soporte Leva Clutch	1
27010	27010-0729	Swiche Clutch	1
46003	46003-0696-18R	Manubrio Negro	1
46012	46012-0010-18R	Soporte Superior Manubrio	1
46019	46019-0060	Carretel Acelerador	1
46075	46075-0564	Caucho Manillar Izquierdo	1
46076	46076-0143	Soporte y Leva Clutch	1
46091	46091-0352	Comando Derecho	1
46091A	46091-0353	Comando Izquierdo	1
46092	46092-0571	Leva Clutch	1
56001	56001-0299	Espejo Izquierdo	1
56001A	56001-0300	Espejo Derecho	1
92009	92009-1134	Tornillo Tensor Cable	1
92015	92015-1197	Tuerca Tornillo Tensor Cable	1
92151	92151-1986	Tornillo Leva Clutch	1
92154	92154-1299	Tornillo 6x55	2
92154A	92154-1422	Tornillo 6x22	1
92161	92161-1926	Antivibrante	2
92161A	92161-1930	Antivibrante 10x16x10	2
92172	92172-0788	Tornillo 3x16	2
92173	92173-1386	Guía Buje Manubrio	2
92210	92210-0006	Tuerca 6 mm.	1
132	132BC0830	Tornillo 8x30	4
220	220AB0522	Tornillo 5x22	2
220A	220AB0540	Tornillo 5x40	2
410	410AB0600	Arandela 6 mm.	1

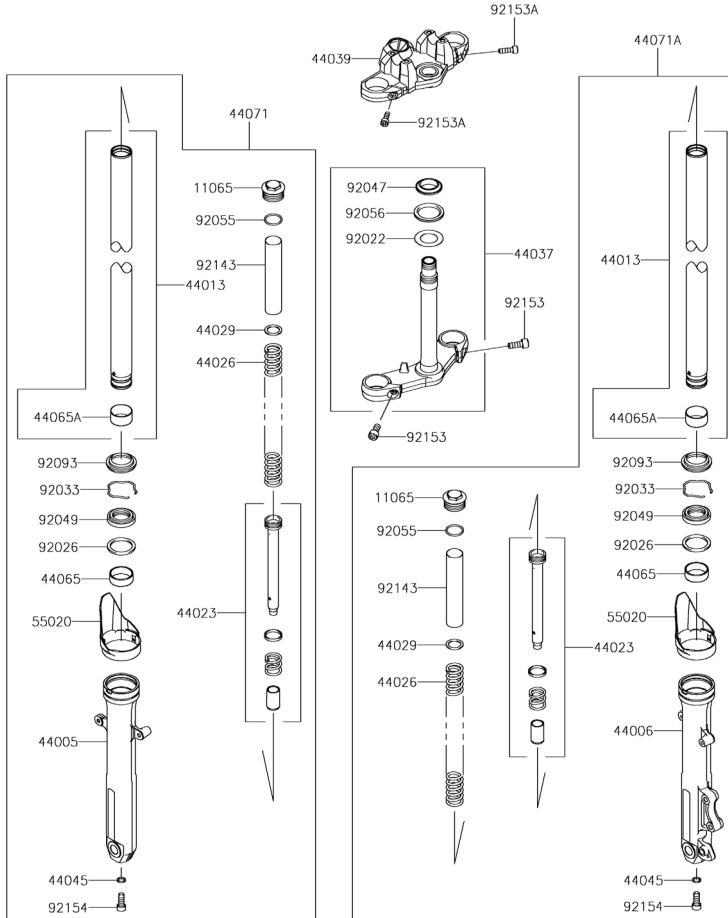

Fig N°	Parte No.	Descripción	18
			CJF
11065	11065-0997	Tapón Tubo Telescópico	2
44005	44005-0117-18R	Camisa Tubo Telescópico Izq. Negra	1
44006	44006-0114-18R	Camisa Tubo Telescópico Der. Negra	1
44013	44013-0305	Tubo Telescópico	2
44023	44023-0140	Cilindro Interno Tubo Telescópico	2
44026	44026-0210	Resorte Tubo Telescópico	2
44029	44029-1131	Arandela	2
44037	44037-0171-21	Espiga Central Negra	1
44039	44039-0169-18R	Cabeza Espiga Negra	1
44045	44045-051	Arandela Sellado	2
44065	44065-0030	Buje Tubo Telescópico	2
44065A	44065-0036	Buje Tubo Telescópico	2
44071	44071-1306-18R	Telescópico Izquierdo Negro Completo	1
44071A	44071-1307-18R	Telescópico Derecho Negro Completo	1
55020	55020-1996	Protector Tubo Telescópico	2
92022	92022-231	Arandela 30.5x50x0.6	1
92026	92026-1276	Arandela Espaciadora	2
92033	92033-1222	Pin Tubo Telescópico	2
92047	92047-012	Cuna Dirección	1
92049	92049-0125	Retenedor	2
92055	92055-1420	Anillo Retenedor	2
92056	92056-003	Retenedor	1
92093	92093-0035	Guardapolvo Suspensión	2
92143	92143-1251	Buje 150 mm.	2
92153	92153-0301	Tornillo 10x25	2
92153A	92153-1625	Tornillo 8x25	2
92154	92154-2551	Tornillo	2

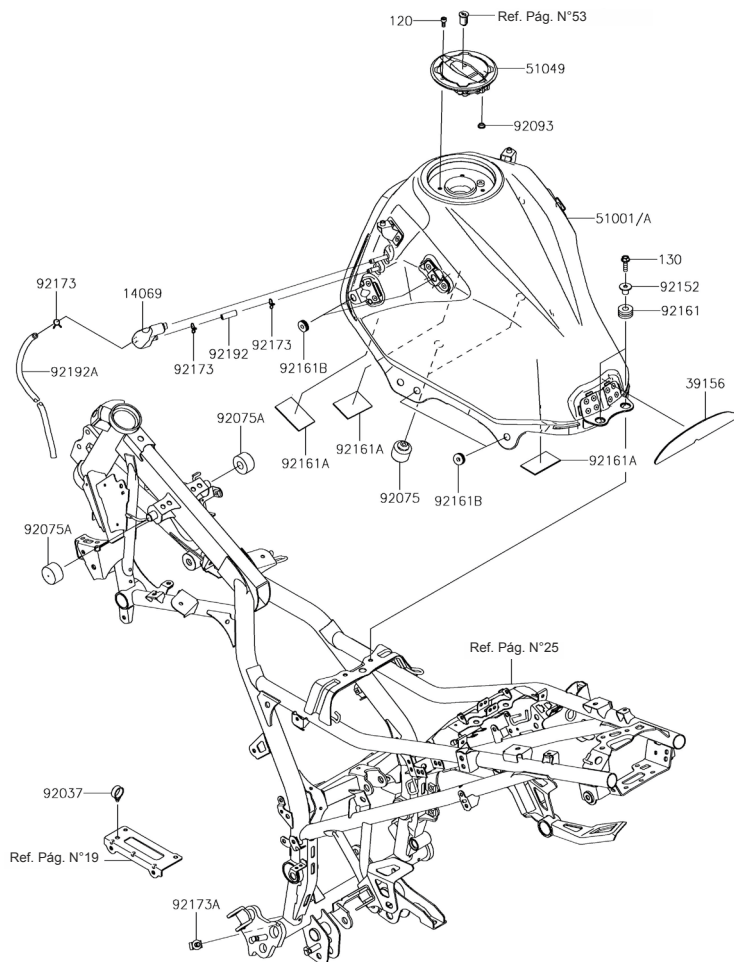

Fig N°	Parte No.	Descripción	18
			CJF
14069	14069-0011	Desfogue	1
39156	39156-2210	Protector 34x210x2	1
51001	51001-0843-45W	Tanque Gasolina Gris	1
51001A	51001-0843-51P	Tanque Gasolina Verde	1
51049	51049-0735	Tapa Tanque Gasolina	1
92037	92037-1827	Abrazadera	1
92075	92075-1002	Antivibrante	2
92075A	92075-1115	Antivibrante	2
92093	92093-1030	Anillo Retenedor Tapa Tanque Gasolina	1
92152	92152-0332	Buje 6.5x10x13.1	2
92161	92161-0927	Antivibrante 10x24x12	2
92161A	92161-1883	Antivibrante	3
92161B	92161-1911	Antivibrante 6x19x5.6	8
92173	92173-0049	Abrazadera	3
92173A	92173-0736	Abrazadera 12 mm.	1
92192	92192-0910	Conducto 5x9x26	1
92192A	92192-1732	Conducto 5x9x1040	1
120	120CA0512	Tornillo 5x12	4
130	130BA0622	Tornillo 6x22	2

Fig N°	Parte No.	Descripción	18
			CJF
53003	53003-0439-MA	Forro Sillín	1
53066	53066-0547-MA	Sillín	1
92075	92075-015	Antivibrante Sillín	6
92161	92161-0855	Antivibrante Sillín 10x20x8	2
92161A	92161-1685	Antivibrante Sillín 8x22x10	2

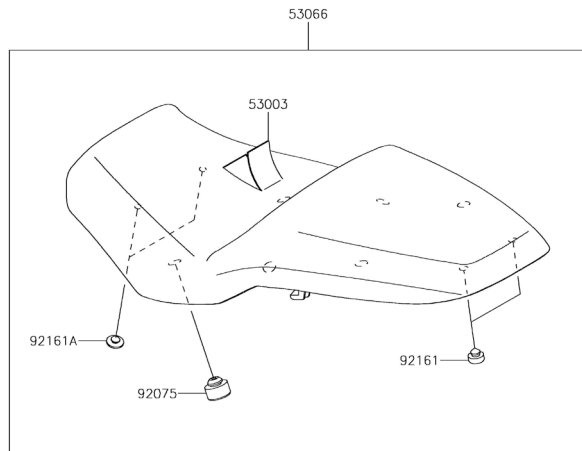
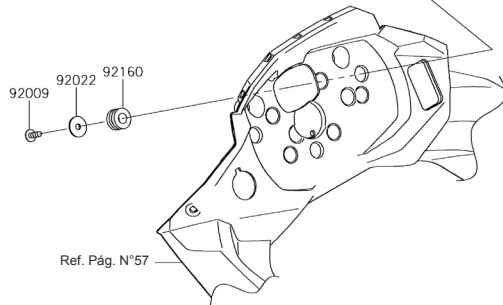
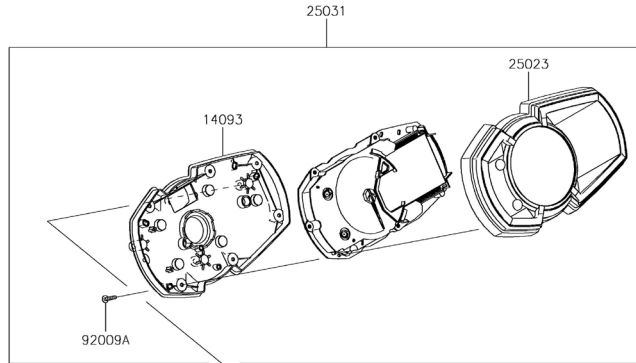

Fig N°	Parte No.	Descripción	18
			CJF
14093	14093-0513	Cubierta Inferior Velocímetro	1
25023	25023-0129	Cubierta Superior Velocímetro	1
25031	25031-0740	Velocímetro Completo	1
92009	92009-1197	Tornillo Cubierta Velocímetro 5x14	3
92009A	92009-1391	Tornillo Cubierta Velocímetro 3x16	9
92022	92022-1405	Arandela 5.5x20x1.2	3
92160	92160-1167	Antivibrante Velocímetro 10x20x12	3



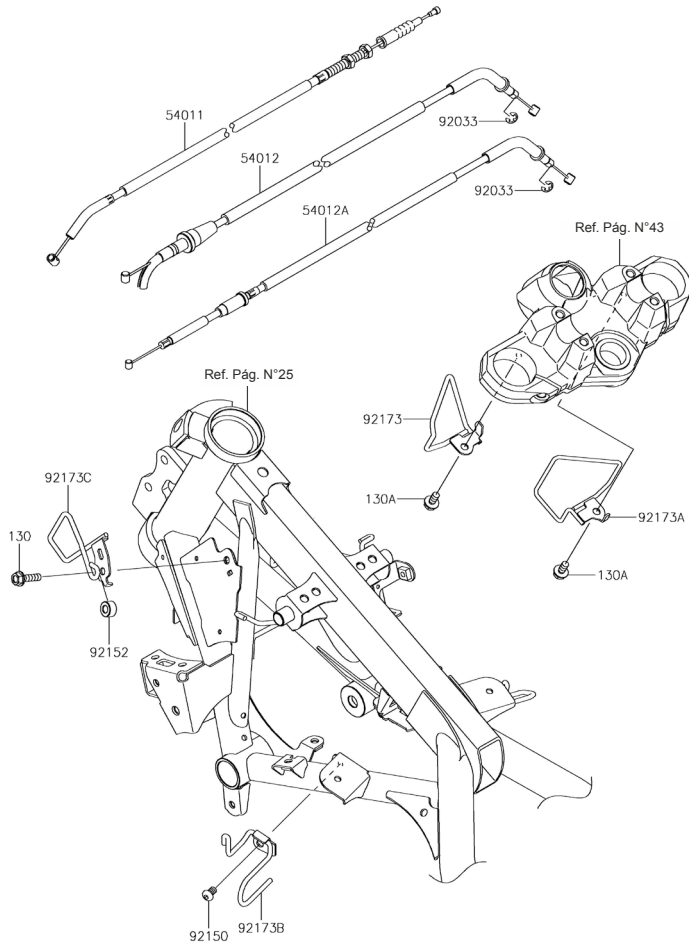

Fig N°	Parte No.	Descripción	18
			CJF
54011	54011-0622	Cable Clutch	1
54012	54012-0650	Cable Acelerador Apertura	1
54012A	54012-0651	Cable Acelerador Retorno	1
92033	92033-0787	Pin de Seguridad	2
92150	92150-1577	Tornillo 6x10	1
92152	92152-2352	Buje 6.5x14x8	1
92173	92173-1629	Guía Superior Izquierda	1
92173A	92173-1630	Guía Superior Derecha	1
92173B	92173-1631	Guía Cable Acelerador	1
92173C	92173-1813	Guía Cable Clutch	1
130	130BA0622	Tornillo 6x22	1
130A	130BB0612	Tornillo 6x12	2

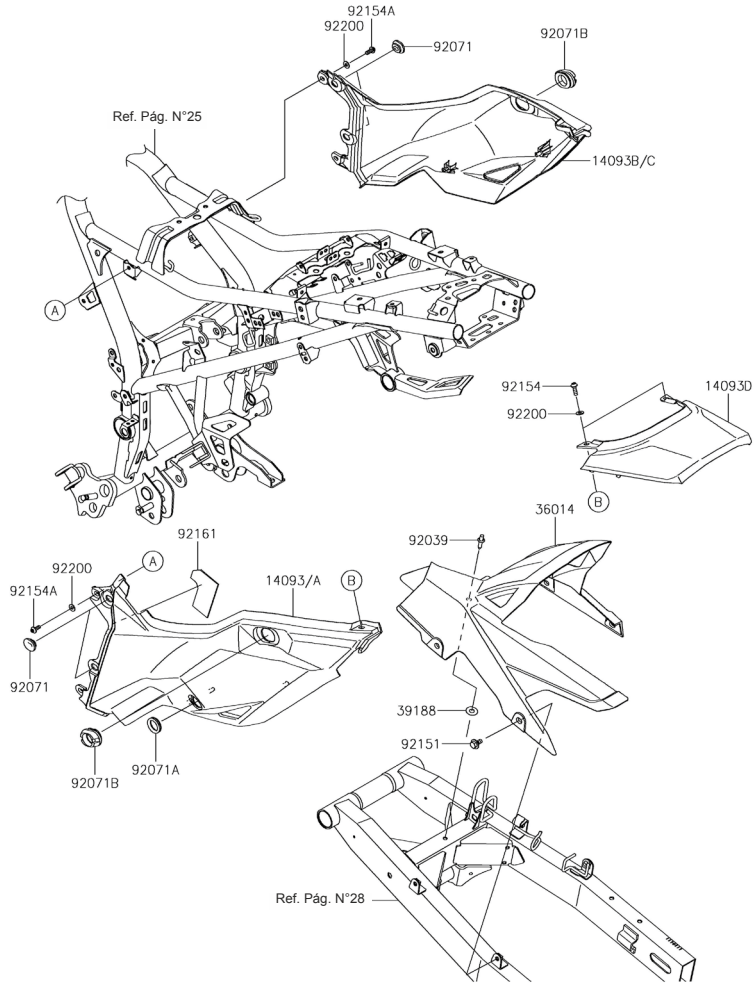

Fig N°	Parte No.	Descripción	18
			CJF
14093	14093-0554-45L	Cubierta Sillín Izquierda Negra	1
14093A	14093-0554-45W	Cubierta Sillín Izquierda Gris	1
14093B	14093-0555-45L	Cubierta Sillín Derecha Negra	1
14093C	14093-0555-45W	Cubierta Sillín Derecha Gris	1
14093D	14093-0556	Cubierta Sillín Central	1
36014	36014-0569	Guardacadena	1
39188	39188-0046	Antivibrante 8x19	1
92039	92039-0709	Remache	1
92071	92071-0766	Tapón 20x24x7.5	4
92071A	92071-0767	Antivibrante 19.4x22.4x5.9	1
92071B	92071-0772	Antivibrante 26.4x42.4x15.8	2
92151	92151-1703	Tornillo 6x13	4
92154	92154-0209	Tornillo 5x16	2
92154A	92154-0917	Tornillo 5x12	4
92161	92161-2070	Adhesivo 54x70x2	1
92200	92200-0784	Arandela 5.2x12x1.0	6

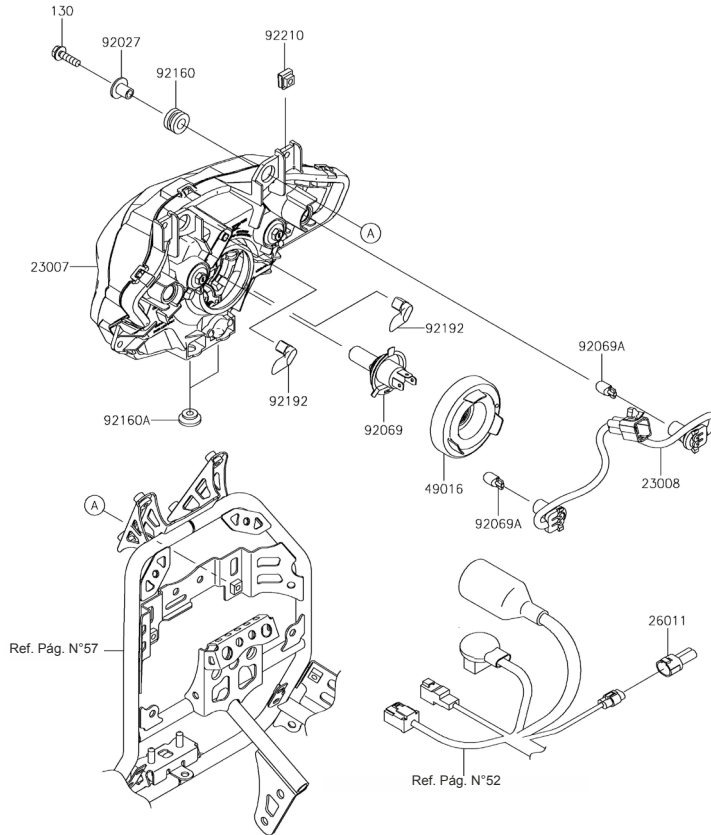

Fig N°	Parte No.	Descripción	18
			CJF
23007	23007-0207	Unidad Farola	1
23008	23008-0177	Soquete Bombillo Farola	1
26011	26011-0967	Terminal Cable	1
49016	49016-0627	Capuchón Bombillo Farola	1
92027	92027-1183	Buje 6.5x10x14.1	2
92069	92069-0050	Bombillo Farola 12V 60/55W-H4	1
92069A	92069-1016	Bombillo Piloto 12V-5W	2
92160	92160-1167	Antivibrante 10x20x12	2
92160A	92160-1613	Antivibrante	2
92192	92192-1528	Conducto de Respiración	2
92210	92210-0776	Tuerca 5 mm.	2
130	130BA0622	Tornillo 6x22	2

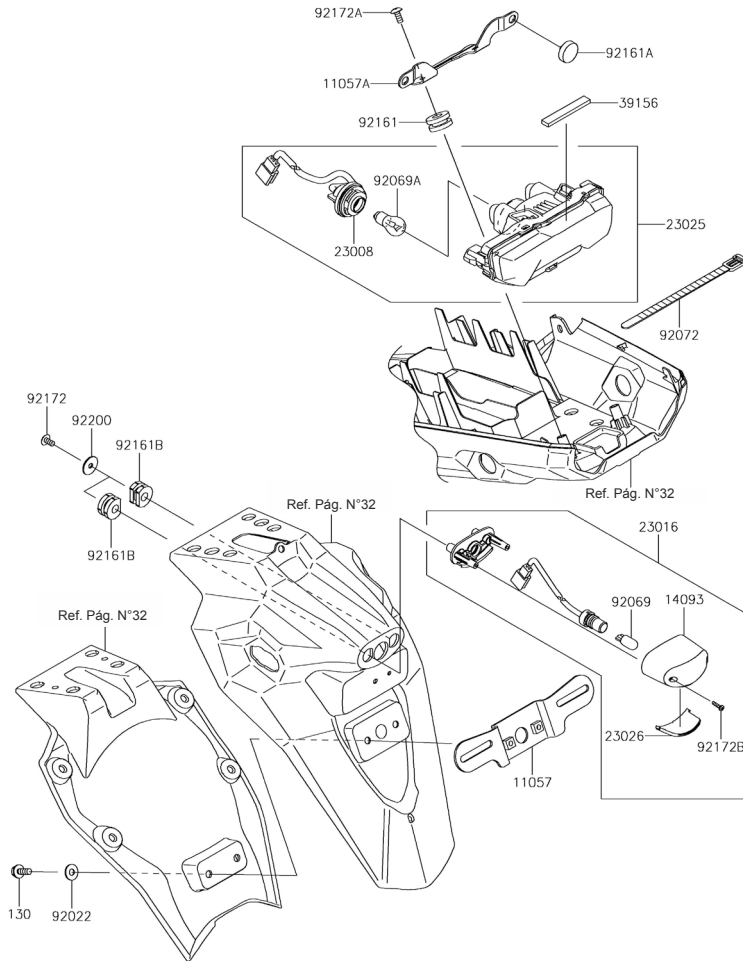

Fig N°	Parte No.	Descripción	18
			CJF
11057	11057-1045	Soporte Porta Placa	1
11057A	11057-1351	Soporte Stop	1
14093	14093-0525	Cubierta Luz Placa	1
23008	23008-0182	Soquete Bombillo Stop	1
23016	23016-0600	Luz Placa Completa	1
23025	23025-0363	Stop Completo	1
23026	23026-0025	Vidrio Inferior Luz Placa	1
39156	39156-0820	Antivibrante 9x60x4	1
92022	92022-1093	Arandela 6.5x16x1.0	2
92069	92069-1016	Bombillo Luz Placa 12V-5W 12V 5W	1
92069A	92069-1084	Bombillo Stop 12V-21/5W	1
92072	92072-1293	Abrazadera 140 mm.	1
92161	92161-0163	Antivibrante	2
92161A	92161-0336	Antivibrante	2
92161B	92161-0776	Antivibrante	2
92172	92172-0427	Tornillo 5x16	2
92172A	92172-0821	Tornillo 5x12	2
92172B	92172-0904	Tornillo 4x12	2
92200	92200-0284	Arandela 5.5x20x1.2	2
130	130BA0616	Tornillo 6x16	2

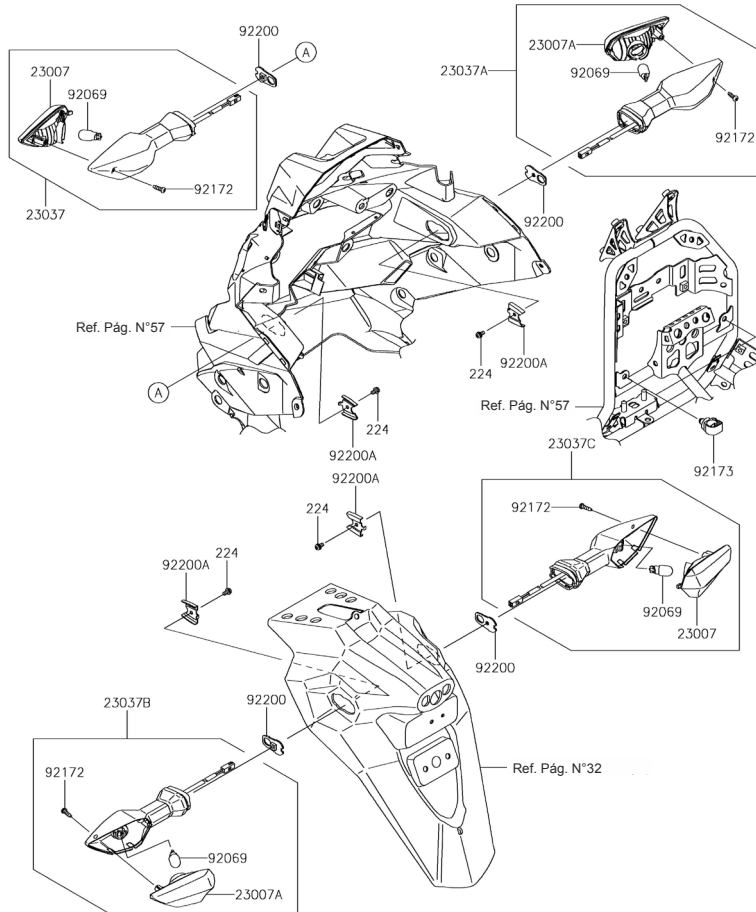

Fig N°	Parte No.	Descripción	18
			CJF
23007	23007-0205	Vidrio Direccional Del. Izq. Tras. Der.	2
23007A	23007-0206	Vidrio Direccional Del. Der. Tras. Izq.	2
23037	23037-0330	Direccional Delantera Izquierda	1
23037A	23037-0331	Direccional Delantera Derecha	1
23037B	23037-0348	Direccional Trasera Izquierda	1
23037C	23037-0349	Direccional Trasera Derecha	1
92069	92069-0090	Bombillo Direccional 12V-10W	4
92172	92172-1117	Tornillo 4x14	4
92173	92173-0736	Abrazadera 12 mm.	2
92200	92200-0854	Platina Direccional 4 mm.	4
92200A	92200-0855	Platina Direccional	4
224	224AB0408	Tornillo 4x8	4

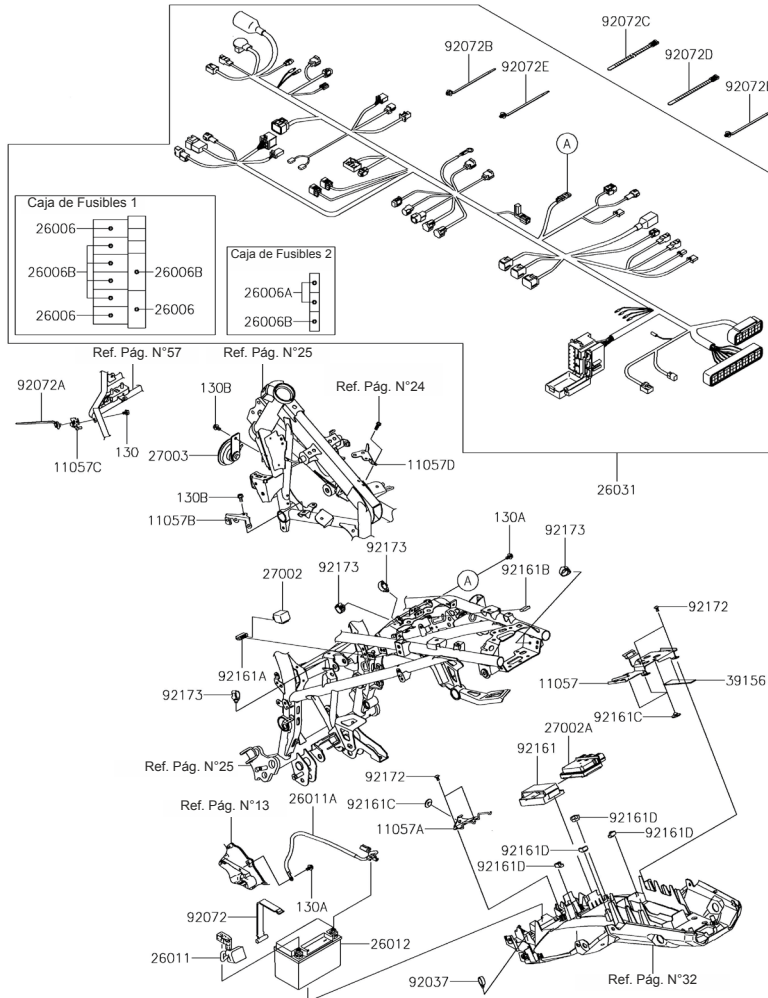

Fig N°	Parte No.	Descripción	18
			CJF
11057	11057-0558	Platina Soporte E.C.U	1
11057A	11057-0559	Platina Soporte Guardabarro Trasero	1
11057B	11057-0566	Platina Soporte Izquierda	1
11057C	11057-0703	Platina Soporte Relay	1
11057D	11057-1220	Platina Soporte Derecha	1
26006	26006-0001	Fusible 15A	3
26006A	26006-1077	Fusible 5A	2
26006B	26006-1078	Fusible 10A	6
26011	26011-0960	Cable Batería (+)	1
26011A	26011-0961	Cable Batería (-)	1
26012	MF12V9-1A-AUTECO	Batería 12V 8AH (Seca)	1
	YTX9-BS-GEL-AUTECO	Batería 12V 8AH (Gel)	1
26031	26031-2374	Instalación Eléctrica	1
27002	27002-0006	Flasher Direccional	1
27002A	27002-0028	Relay Arranque	1
27003	27003-0124	Pito	1
39156	39156-2145	Antivibrante 28x112x2	1
92037	92037-1827	Abrazadera	1
92072	92072-0749	Banda Batería	1
92072A	92072-0807	Abrazadera	1
92072B	92072-0813	Abrazadera	11
92072C	92072-1237	Abrazadera 250 mm.	1
92072D	92072-1293	Abrazadera 140 mm.	5
92072E	92072-1414	Abrazadera 170 mm.	11
92161	92161-0203	Antivibrante Relay Arranque	1
92161A	92161-1443	Antivibrante 15x25x8.5	1
92161B	92161-1472	Antivibrante	1
92161C	92161-1685	Antivibrante 8x22x10	4
92161D	92161-1909	Antivibrante	4
92172	92172-0262	Tornillo 5x10	4
92173	92173-0868	Abrazadera	4
130	130BA0608	Tornillo 6x8	1
130A	130BA0610	Tornillo 6x10	2
130B	130BA0612	Tornillo 6x12	2

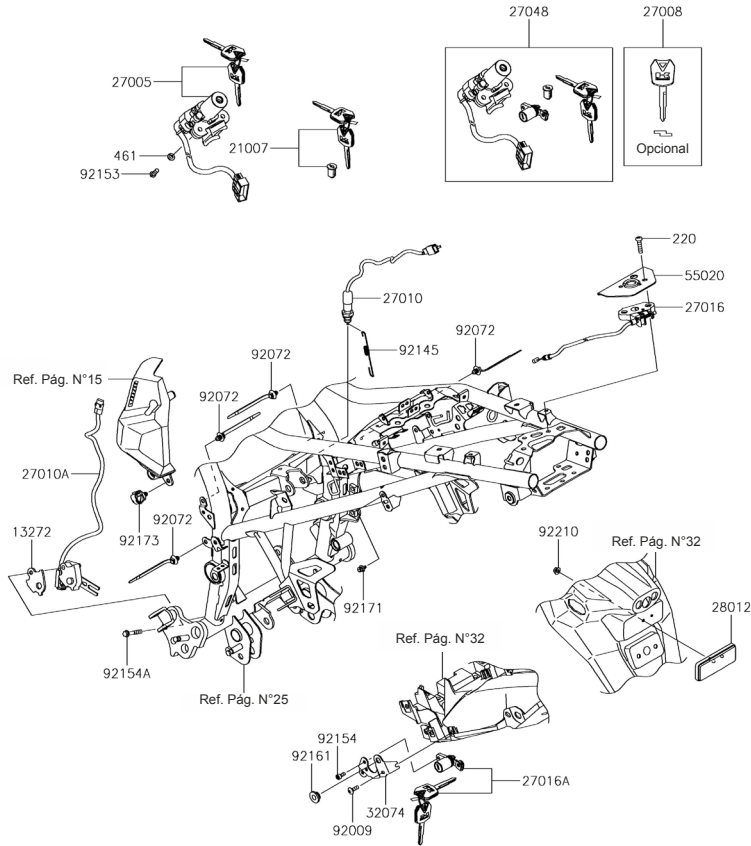

Fig N°	Parte No.	Descripción	18
			CJF
13272	13272-1330	Platina Soporte Swiche Gato Lateral	1
21007	21007-5082	Seguro Tapa Tanque Gasolina	1
27005	27005-5162	Swiche de Encendido (Solo)	1
27008	27008-0053	Llave en Blanco (Opcional)	1
27010	27010-0726	Swiche Stop	1
27010A	27010-0845	Swiche Gato Lateral	1
27016	27016-0089	Seguro Sillín	1
27016A	27016-5398	Seguro Sillín	1
27048	27048-5139	Swiche de Encendido (Completo)	1
28012	28012-1077	Reflectivo	1
32074	32074-0022	Platina Soporte Seguro Sillín	1
55020	55020-1987	Platina Soporte Seguro Sillín	1
92009	92009-1654	Tornillo 5x16	2
92072	92072-1414	Abrazadera 170 mm.	4
92145	92145-0144	Resorte Swiche Stop	1
92153	92153-0967	Tornillo 6x16	2
92154	92154-0933	Tornillo 5x12	2
92154A	92154-1009	Tornillo 6x35	1
92161	92161-1531	Antivibrante	1
92171	92171-0939	Abrazadera	1
92173	92173-0736	Abrazadera 12 mm.	1
92210	92210-0007	Tuerca 5 mm.	1
220	220AA0625	Tornillo 6x25	2
461	461DA0600	Arandela 6 mm.	2

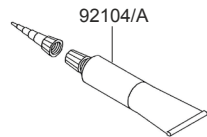
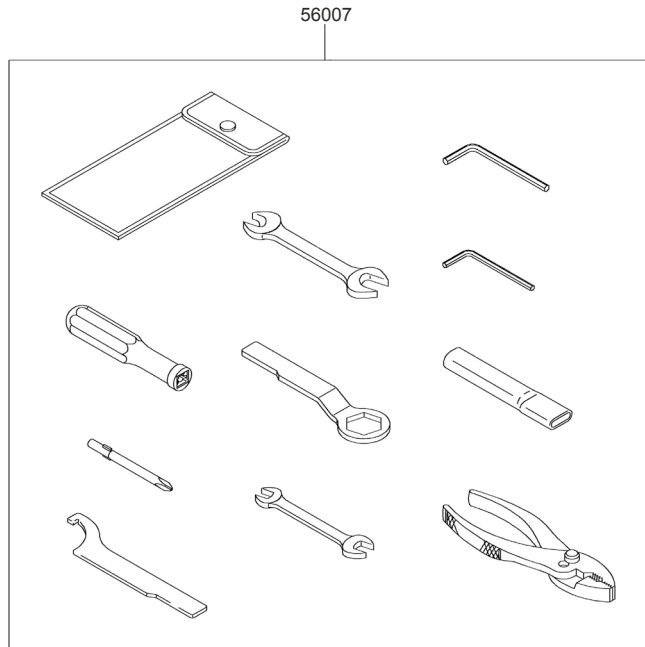

Fig N°	Parte No.	Descripción	18
			CJF

56007	56007-0157	Estuche de Herramienta	1
92104	92104-0004	Pegante Empaques	1
92104A	92104-1064	Pegante Empaques	1

Fig N°	Parte No.	Descripción	18
			CJF

56054	56054-2239	Calcomanía Sup. Cubierta Lateral	2
56054A	56054-2250	Calcomanía Inf. Cubierta Lateral	2
56054B	56054-2261	Calcomanía Visor Carenaje	1

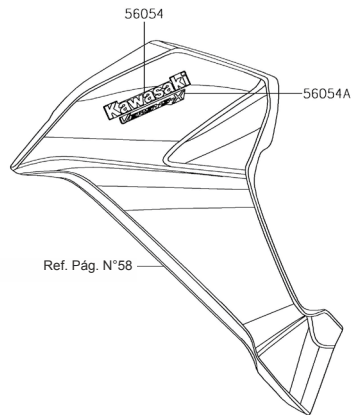
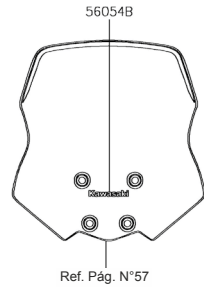
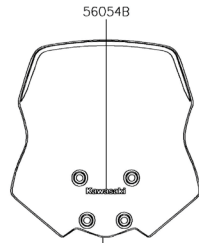
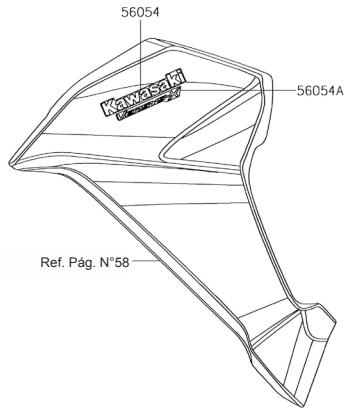

Fig N°	Parte No.	Descripción	18
			CJF

56054	56054-2239	Calcomanía Sup. Cubierta Lateral	2
56054A	56054-2240	Calcomanía Inf. Cubierta Lateral	2
56054B	56054-2261	Calcomanía Visor Carenaje	1



Ref. Pág. N°57



Ref. Pág. N°58

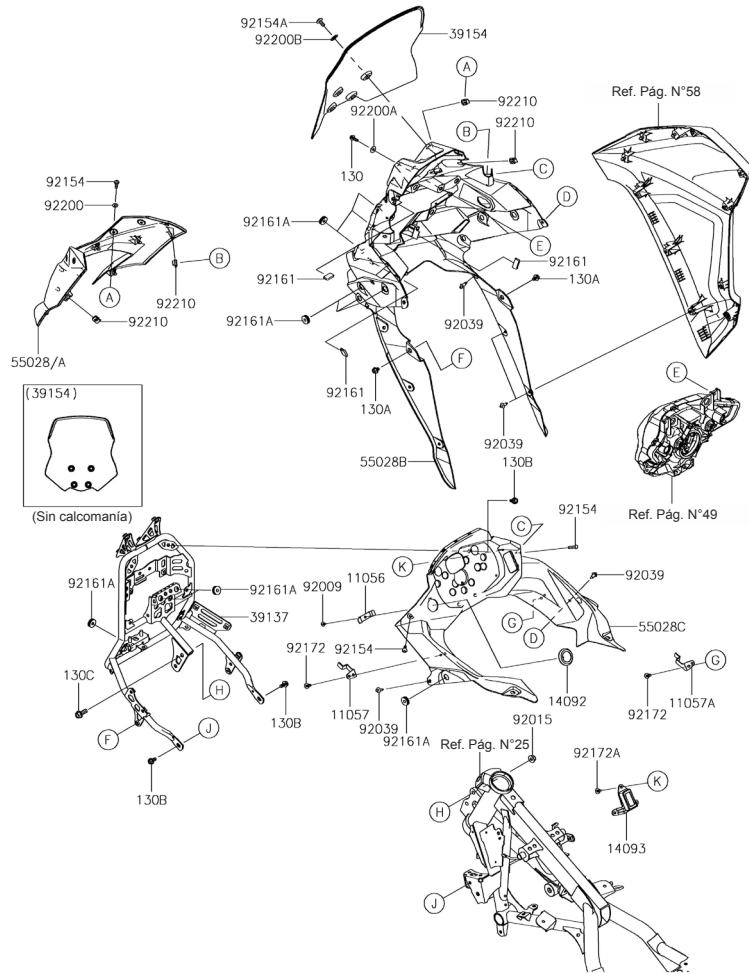

Fig N°	Parte No.	Descripción	18
			CJF
11056	11056-4313	Platina Soporte Cubierta Velocimetro	1
11057	11057-0913	Platina Soporte Cubierta Velocimetro Izq.	1
11057A	11057-0914	Platina Soporte Cubierta Velocimetro Der.	1
14092	14092-0214	Tapon Cubierta Velocimetro	1
14093	14093-0565	Tapa Cubierta Velocimetro	1
39137	39137-0680	Soporte Carenaje	1
39154	39154-0358	Visor	1
55028	55028-0624-45W	Carenaje Superior Gris	1
55028A	55028-0624-51P	Carenaje Superior Verde	1
55028B	55028-0625	Carenaje Delantero Interno	1
55028C	55028-0630	Cubierta Velocimetro	1
92009	92009-1155	Tornillo 4x8	1
92015	92015-1014	Tuerca 8 mm.	2
92039	92039-0707	Remache	8
92154	92154-0209	Tornillo 5x16	6
92154A	92154-0932	Tornillo 6x14	4
92161	92161-1367	Antivibrante 12x23	3
92161A	92161-1911	Antivibrante 6x19x5.6	17
92172	92172-0821	Tornillo 5x12	4
92172A	92172-0864	Tornillo 5X10	3
92200	92200-0006	Arandela 5.3x11.5x0.5	4
92200A	92200-0456	Arandela 5.2x15x1.0	2
92200B	92200-1890	Arandela 11.4x18x1	4
92210	92210-0817	Tuerca 5 mm.	6
130	130BA0514	Tornillo 5x14	2
130A	130BA0608	Tornillo 6x8	2
130B	130BB0612	Tornillo 6x12	4
130C	130CA0820	Tornillo 8x20	2

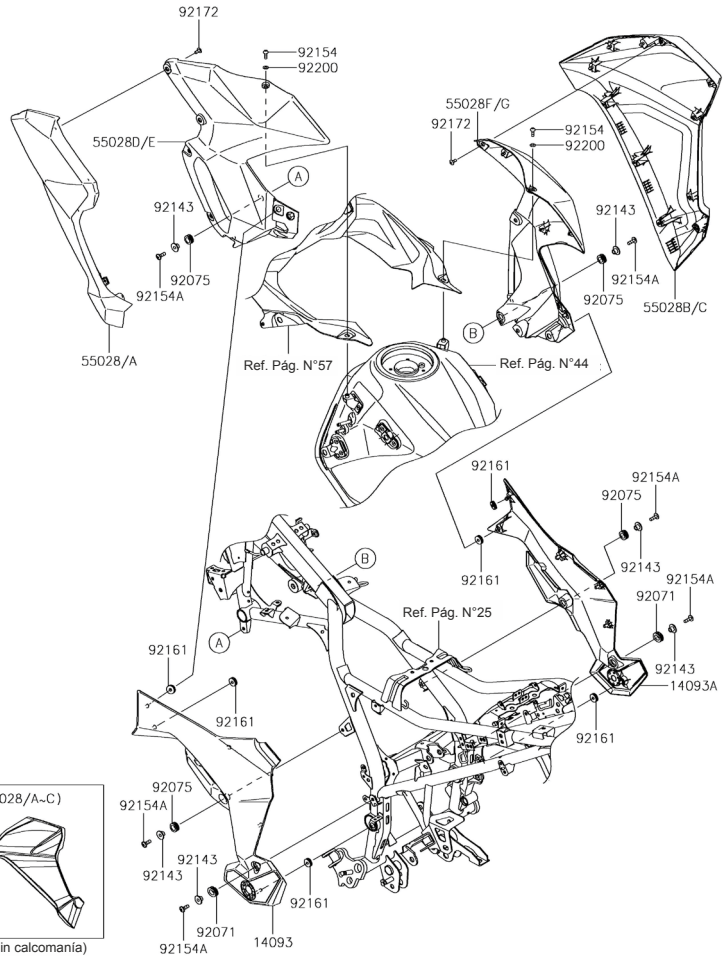

Fig N°	Parte No.	Descripción	18
			CJF
14093	14093-0558	Tapa Lateral Izquierda	1
14093A	14093-0559	Tapa Lateral Derecha	1
55028	55028-0626-45W	Carenaje Lateral Izquierdo Gris	1
55028A	55028-0626-51P	Carenaje Lateral Izquierdo Verde	1
55028B	55028-0627-45W	Carenaje Lateral Derecho Gris	1
55028C	55028-0627-51P	Carenaje Lateral Derecho Verde	1
55028D	55028-0628-45L	Cubierta Lat. Tanque Gas. Izq. Negro	1
55028E	55028-0628-45W	Cubierta Lat. Tanque Gas. Izq. Gris	1
55028F	55028-0629-45L	Cubierta Lat. Tanque Gas. Der. Negro	1
55028G	55028-0629-45W	Cubierta Lat. Tanque Gas. Der. Gris	1
92071	92071-0768	Antivibrante 20x24x8	2
92075	92075-1634	Antivibrante	4
92143	92143-1016	Buje	6
92154	92154-0209	Tornillo 5x16	2
92154A	92154-2340	Tornillo 6x18	6
92161	92161-1911	Antivibrante 6x19x5.6	6
92172	92172-0821	Tornillo 5x12	10
92200	92200-0006	Arandela 5.3x11.5x0.5	2

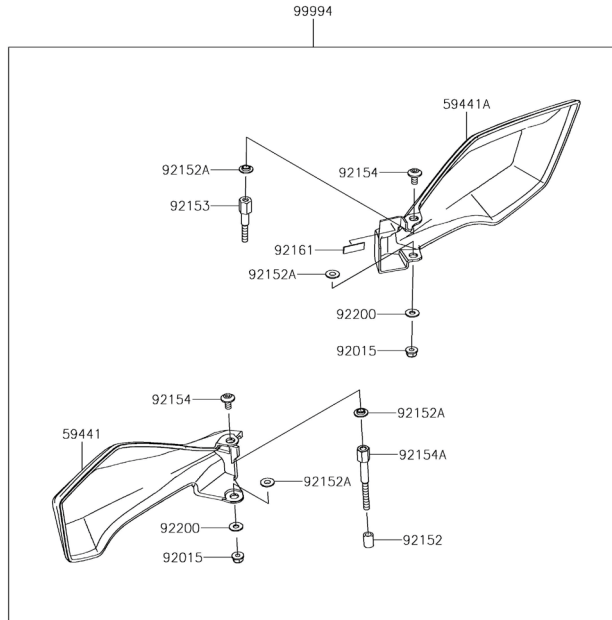

Fig N°	Parte No.	Descripción	18
			CJF
59441	59441-0043	Cortaviento Izquierdo	1
59441A	59441-0044	Cortaviento Derecho	1
92015	92015-1603	Tuerca 6 mm.	2
92152	92152-2302	Buje 6.5x10.5x14	1
92152A	92152-2314	Buje 6.5x15x3.4	4
92153	92153-0790	Tornillo Ajuste Cortaviento Derecho	1
92154	92154-0951	Tornillo 6x12	2
92154A	92154-2359	Tornillo Ajuste Cortaviento Izquierdo	1
92161	92161-1985	Antivibrante 10x30x1	1
92200	92200-1762	Arandela 6.2x15x1.2	2
99994	99994-0992	Kit Cortavientos	1

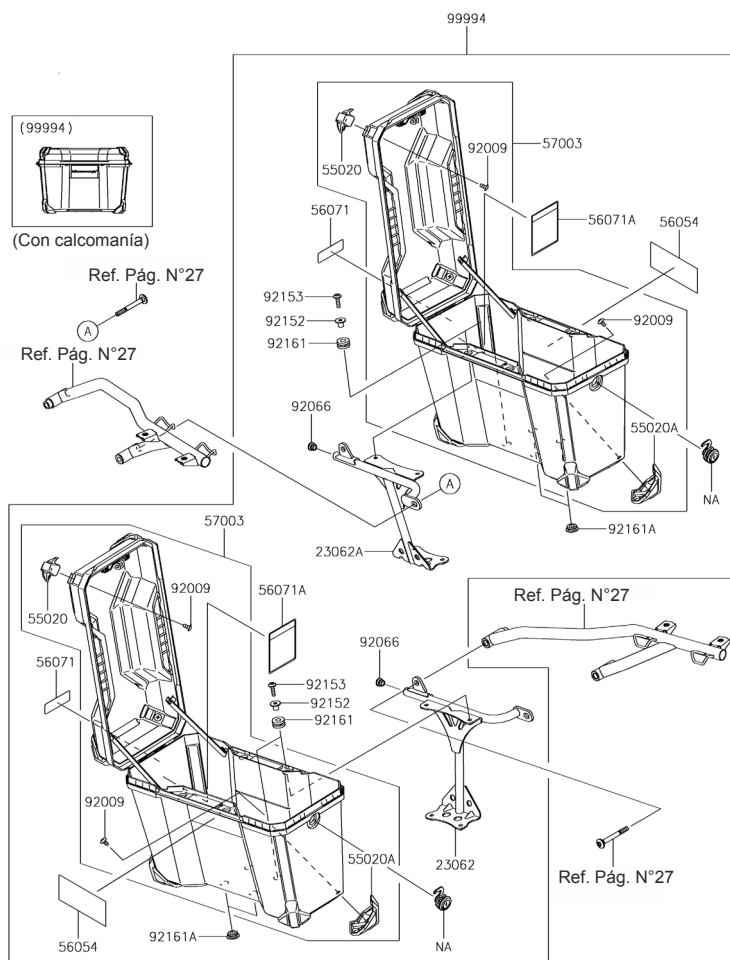

Fig N°	Parte No.	Descripción	18
			CJF
23062	23062-0965	Soporte Maletero Izquierdo	1
23062A	23062-0966	Soporte Maletero Derecho	1
55020	55020-2174	Protector Superior	8
55020A	55020-2175	Protector Inferior	8
56054	56054-2241	Calcomanía "VERSYS-X"	2
56071	56071-0457	Calcomanía Precaución	2
56071A	56071-0724	Calcomanía Precaución	2
57003	57003-0152	Maletero (Solo)	2
92009	92009-1480	Tornillo 6x12	16
92066	92066-1184	Tapón Soporte Maletero	2
92152	92152-0332	Buje 6.5x10x13.1	8
92153	92153-1267	Tornillo 6x23	8
92161	92161-0927	Antivibrante 10x24x12	8
92161A	92161-1910	Antivibrante	4
99994	99994-0993	Kit Maleteros	1

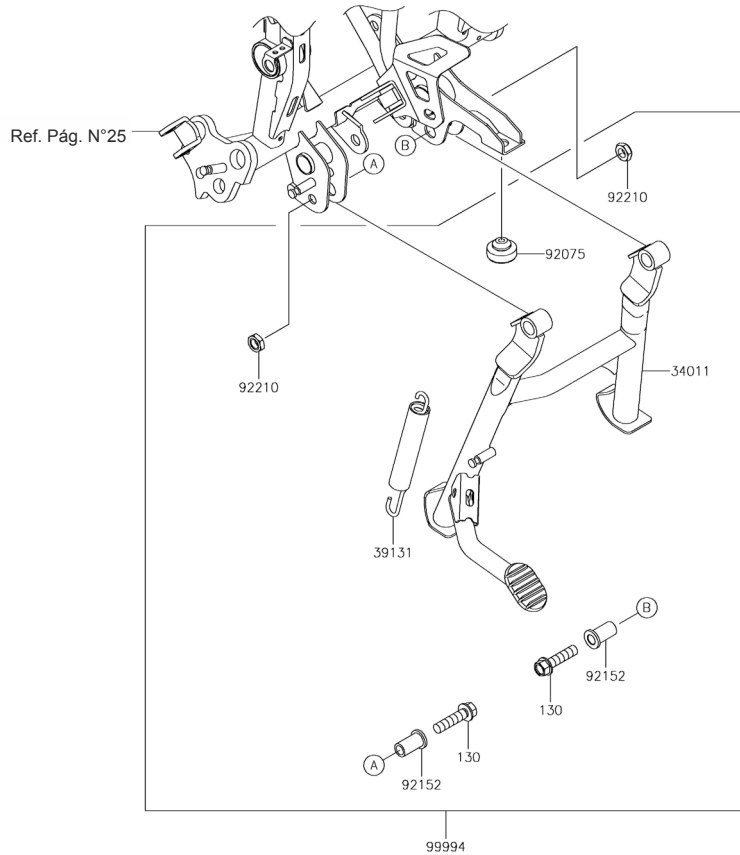

Fig N°	Parte No.	Descripción	18
			CJF
34011	34011-0036	Gato Central	1
39131	39131-0001	Resorte Gato Central	1
92075	92075-1045	Antivibrante	1
92152	92152-2350	Buje 10.2x14.7x28.8	2
92210	92210-0784	Tuerca 10 mm.	2
99994	99994-0995	Kit Gato Central	1
130	130CB1040	Tornillo 10x40	2

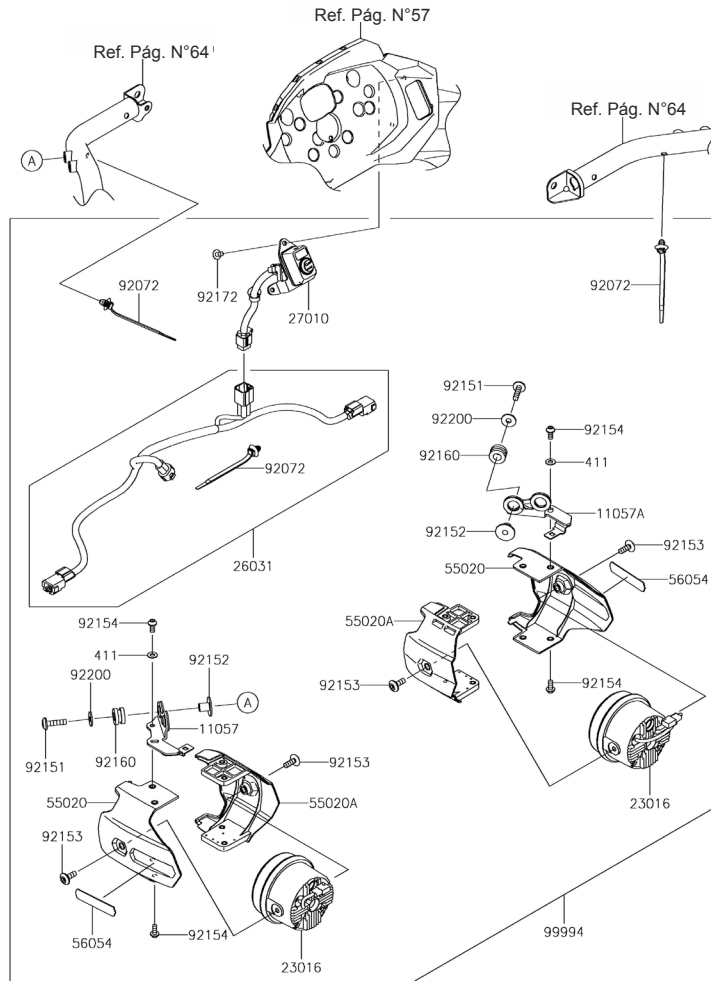
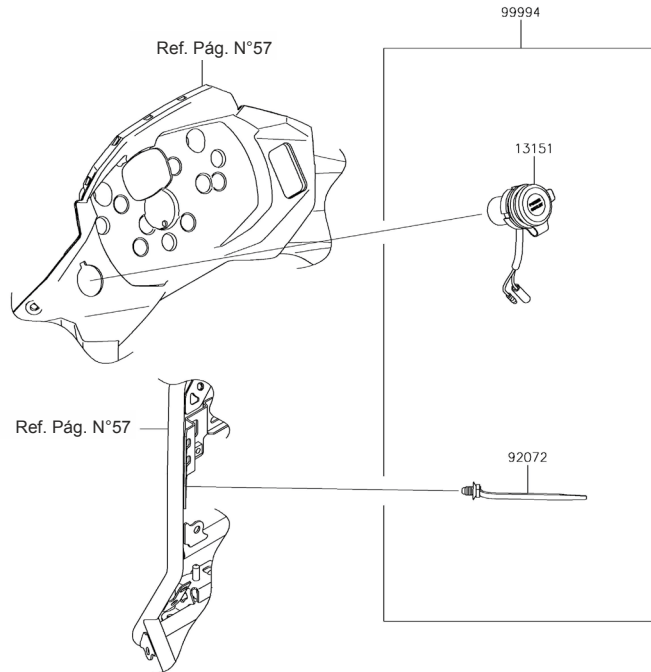

Fig N°	Parte No.	Descripción	18
			CJF
11057	11057-0624	Soporte Exploradora Izquierda	1
11057A	11057-0625	Soporte Exploradora Derecha	1
23016	23016-0599	Exploradora (Sola)	2
26031	26031-2337	Instalación Conexión Exploradoras	1
27010	27010-0850	Swiche Conexión Exploradoras	1
55020	55020-1825	Protector Exploradoras Externo	2
55020A	55020-1826	Protector Exploradoras Interno	2
56054	56054-1695	Calcomanía "KAWASAKI"	2
92072	92072-1414	Abrazadera 170 mm.	6
92151	92151-1611	Tornillo 6x25	4
92152	92152-2204	Buje 6.5x10x13.6	4
92153	92153-1526	Tornillo 6x16	4
92154	92154-0917	Tornillo 5x12	8
92160	92160-1167	Antivibrante 10x20x12	4
92172	92172-0864	Tornillo 5x10	3
92200	92200-0766	Arandela 6.5x18x1.6	4
99994	99994-0996	Kit Exploradoras	1
411	411AB0500	Arandela 5 mm.	4

Fig N°	Parte No.	Descripción	18
			CJF

13151	13151-0566	Swiche de Corriente DC 12V	1
92072	92072-1414	Abrazadera 170 mm.	1
99994	99994-0997	Kit Swiche Corriente DC 12V	1



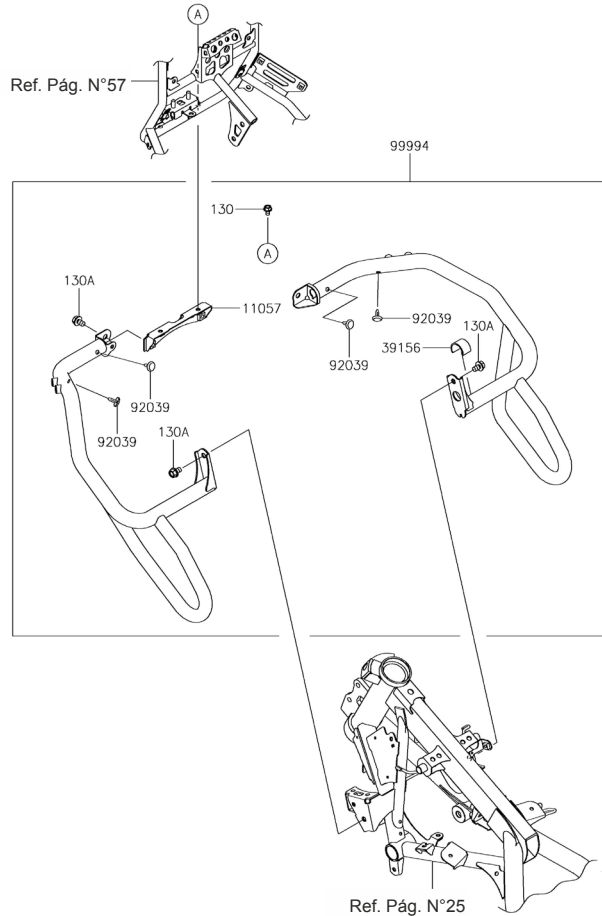
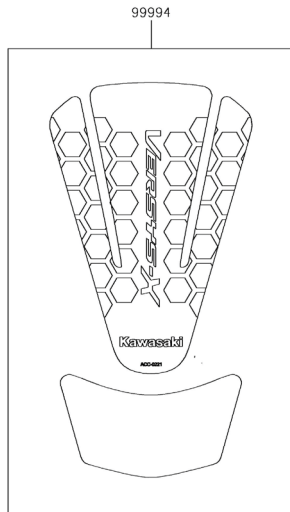

Fig N°	Parte No.	Descripción	18
			CJF
11057	11057-0597	Soporte Protector Motor	1
39156	39156-1909	Antivibrante 50x18x2	1
92039	92039-3787	Remache	4
99994	99994-0998	Kit Protector Motor	1
130	130BB0610	Tornillo 6x10	2
130A	130BB0812	Tornillo 8x12	4

Fig N°	Parte No.	Descripción	18
			CJF
99994	99994-1000	Kit Protector Tanque	1



Ref. Pág. N°44

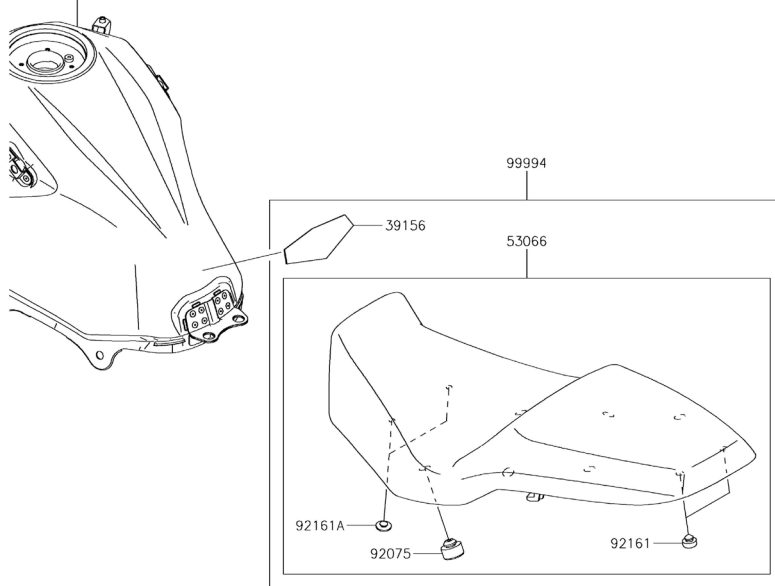
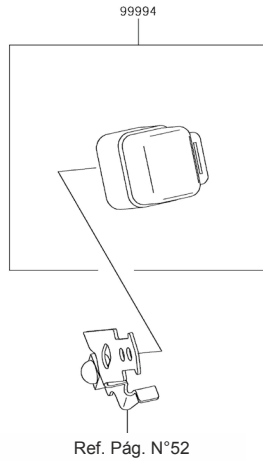

Fig N°	Parte No.	Descripción	18
			CJF
39156	39156-0801	Protector Tanque Gasolina	1
53066	53066-0566-MA	Sillin Doble Altura	1
92075	92075-015	Antivibrante	6
92161	92161-0855	Antivibrante 10x20x8	2
92161A	92161-1685	Antivibrante 8x22x10	2
99994	99994-1002	Kit Sillin Doble Altura	1

Fig N°	Parte No.	Descripción	18
			CJF
99994	99994-1004	Kit Relay	1



ÍNDICE NUMÉRICO DE REFERENCIAS

Parte N°	Fig No.	Pág No.	Parte N°	Fig No.	Pág No.	Parte N°	Fig No.	Pág No.	Parte N°	Fig No.	Pág No.	Parte N°	Fig No.	Pág No.
100/90-19-GP210-TL	41009	34	11061-0791	11061A	5	13042-0742	13042	42	13107-0743	13107	22	13280-0105	13280	42
11004-0734	11004	1	11061-0792	11061	7	13042-0759	13042	30	13127-0051	13127	10	13280-0261	13280	22
11005-0682	11005	3	11061-0793	11061	15	13042-0761	13042A	42	13128-0693	13128	10	13280-0301	13280A	22
11008-0748	11008	1	11061-0794	11061A	19	13087-0558	13087	9	13140-1148	13140	11	13280-0882	13280	11
11009-1105	11009	13	11061-0795	11061	24	13088-0590	13088	9	13140-1149	13140A	11	13280-0883	13280	4
11009-1145	11009	23	11061-0854	11061A	15	13088-0591	13088A	9	13144-0577	13144	10	13280-0884	13280A	4
11012-1362	11012	15	11061-0875	11061A	24	13089-0021	13089	9	13145-0556	13145	11	132BA0612	132	15
11012-1871-18R	11012	28	11065-0349	11065	2	13089-0558	13089A	9	13151-0566	13151	63	132BA0614	132	24
11013-0762	11013	4	11065-0967	11065	4	13091-1464	13091	11	13159-0008	13159	40	132BA0620	132	2
11038-0049	11038	4	11065-0969	11065	23	13095-0561	13095	9	13161-0560	13161	12	132BC0830	132	42
11056-4313	11056	57	11065-0997	11065	43	130BA0514	130	57	13187-0553	13187	9	14001-0688	14001	13
11057-0541	11057	19	12004-0749	12004	6	130BA0608	130	52	13193-1002	13193	22	14013-004	14013	13
11057-0542	11057A	19	12005-0770	12005	6	130BA0608	130A	57	13216-0880	13216	22	14014-0564	14014	11
11057-0556	11057	32	12009-1073	12009	6	130BA0610	130	38	13234-0598	13234	8	14014-0565	14014	13
11057-0558	11057	52	12011-1053	12011	6	130BA0610	130A	52	13236-0797	13236	12	14026-0133	14026	15
11057-0559	11057A	52	12021-0708	12021	2	130BA0612	130B	52	13239-0048	13239	11	14031-0562	14031	15
11057-0566	11057B	52	12032-0018	12032	6	130BA0616	130	4	13242-0151	13242	12	14032-0633	14032	15
11057-0597	11057	64	12046-0072	12046	7	130BA0616	130	32	13251-0038-HH	13251	8	14037-0781	14037	23
11057-0623	11057	15	12048-0084	12048	7	130BA0616	130	50	13262-0461	13262	10	14041-0601	14041	5
11057-0624	11057	62	12053-0102	12053	7	130BA0620	130	20	13262-0463	13262A	10	14069-0011	14069	44
11057-0625	11057A	62	12053-0191	12053A	7	130BA0622	130	44	13262-0464	13262B	10	14091-0724	14091	2
11057-0629	11057	38	12053-0235	12053B	7	130BA0622	130	47	13262-0465	13262C	10	14092-0214	14092	57
11057-0674	11057A	15	12053-0237	12053	15	130BA0622	130	49	13262-0466	13262D	10	14092-1002	14092	19
11057-0703	11057C	52	120CA0512	120	44	130BB0610	130	64	13262-0467	13262E	10	14093-0224	14093	24
11057-0913	11057	57	120CA0525	120	18	130BB0612	130A	47	13262-0468	13262F	10	14093-0513	14093	46
11057-0914	11057A	57	120CA0612	120	41	130BB0612	130B	57	13262-0469	13262G	10	14093-0525	14093	50
11057-1045	11057	50	120CA0816	120A	41	130BB0616	130A	32	13262-0470	13262H	10	14093-0548	14093	15
11057-1220	11057D	52	120CA0830	120	40	130BB0812	130A	64	13262-0922	13262I	10	14093-0549	14093A	15
11057-1351	11057A	50	120CB0610	120	22	130CA0820	130C	57	13272-0260	13272	1	14093-0552	14093	32
11061-0282	11061	2	130/80-17-GP210-TL	41009A	34	130CB1040	130	61	13272-0261	13272A	1	14093-0554-45L	14093	48
11061-0283	11061A	2	13001-0728	13001	3	130CC0620	130	12	13272-1257	13272	20	14093-0554-45W	14093A	48
11061-0417	11061	19	13002-1097	13002	3	13102-0073	13102	9	13272-1303	13272	9	14093-0555-45L	14093B	48
11061-0432	11061	5	13008-0047	13008	3	13107-0741	13107	19	13272-1330	13272	53	14093-0555-45W	14093C	48
11061-0790	11061	3	13031-0769	13031	8	13107-0742	13107	24	13272-2247	13272	27	14093-0556	14093D	48

ÍNDICE NUMÉRICO DE REFERENCIAS

Parte N°	Fig No.	Pág No.	Parte N°	Fig No.	Pág No.	Parte N°	Fig No.	Pág No.	Parte N°	Fig No.	Pág No.	Parte N°	Fig No.	Pág No.
14093-0557	14093	27	21176-0111	21176C	18	26011-0967	26011	49	34028-0351	34028D	30	41022-0084	41022	34
14093-0558	14093	58	21176-0832	21176	11	26031-2337	26031	62	35004-0363-45L	35004	31	41022-0085	41022A	34
14093-0559	14093A	58	21176-0839	21176D	18	26031-2374	26031	52	35019-0632	35019	32	41023-0038	41023	34
14093-0565	14093	57	21176-0843	21176	41	27002-0006	27002	52	35019-0634	35019A	32	41023-0039	41023A	34
16007-0028	16007	6	220AA0614	220	20	27002-0028	27002A	52	35023-0427	35023	32	41025-0373-WA	41025	34
16007-0708	16007	9	220AA0625	220	53	27003-0124	27003	52	36014-0569	36014	48	41025-0374-WA	41025A	34
16014-0002	16014	16	220AB0522	220	42	27005-5162	27005	53	39007-0407	39007	29	41029-0087	41029	34
16021-0027	16021	16	220AB0540	220A	42	27008-0053	27008	53	39061-0735	39061	23	41029-0088	41029A	34
16065-0120	16065	1	224AB0408	224	51	27010-0099	27010	22	39062-0693	39062	24	41029-0089	41029B	34
16073-0053	16073	22	225AB0412	225	40	27010-0726	27010	53	39062-0769	39062	23	41032-0005	41032	34
16073-0129	16073	16	23007-0205	23007	51	27010-0729	27010	42	39062-0770	39062A	23	41034-0587-458	41034	35
16085-0133	16085	9	23007-0206	23007A	51	27010-0762	27010	38	39062-0773	39062A	24	41034-0588-458	41034	36
16097-0008	16097	19	23007-0207	23007	49	27010-0845	27010A	53	39062-0793	39062B	24	41068-0623	41068	35
16115-1068	16115	15	23008-0177	23008	49	27010-0850	27010	62	39062-0794	39062C	24	41068-0624	41068	36
16126-0744	16126	4	23008-0182	23008	50	27010-1313	27010	19	39111-0349	39111	29	41080-0671-11H	41080	41
16130-0002	16130	19	23016-0599	23016	62	27016-0089	27016	53	39131-0001	39131	61	41080-0672-11H	41080	39
16142-0707	16142	19	23016-0600	23016	50	27016-5398	27016A	53	39131-0002	39131	33	410AA1000	410	27
16142-0708	16142	24	23025-0363	23025	50	27048-5139	27048	53	39137-0680	39137	57	410AB0600	410	42
16154-0711	16154	19	23026-0025	23026	50	28012-1077	28012	53	39154-0358	39154	57	411AB0500	411	62
16160-0762	16160	24	23037-0330	23037	51	31064-0164	31064	16	39156-0801	39156	66	42036-0816	42036	28
16163-0840	16163	16	23037-0331	23037A	51	32074-0022	32074	53	39156-0820	39156	32	42036-1077	42036	29
16165-0013	16165	13	23037-0348	23037B	51	32155-0029	32155	19	39156-0820	39156	50	42036-1078	42036A	29
21003-0175	21003	20	23037-0349	23037C	51	32190-0740	32190	26	39156-1909	39156	64	42036-1102	42036B	29
21007-0569	21007	20	23062-0965	23062	60	33001-0684-18R	33001	28	39156-2145	39156	52	42041-0120	42041	36
21007-5082	21007	53	23062-0966	23062A	60	33032-1134	33032	28	39156-2198	39156	23	43001-0750	43001	37
21039-0005	21039	22	25023-0129	25023	46	33040-0030-18R	33040	28	39156-2210	39156	44	43010-0021	43010	40
21040-0003	21040	22	25031-0740	25031	46	33040-0088-18R	33040A	28	39156-2211	39156A	32	43015-0656	43015	40
21066-0753	21066	20	26006-0001	26006	52	33040-1116	33040B	28	39178-0272	39178	5	43015-0676	43015	38
21163-0717	21163	22	26006-1006	26006	22	34011-0036	34011	61	39188-0046	39188	48	43020-0022	43020	38
21171-0033	21171	21	26006-1077	26006A	52	34024-0144	34024	33	39192-0590	39192	24	43020-0023	43020	40
21175-1256	21175	18	26006-1078	26006B	52	34028-0334	34028	30	39192-0600	39192A	24	43022-1010	43022	38
21176-0009	21176	18	26011-0958	26011	22	34028-0335	34028A	30	39192-0604	39192B	24	43026-0009	43026	40
21176-0026	21176A	18	26011-0960	26011	52	34028-0349	34028B	30	39193-0571	39193	13	43026-1074	43026	38
21176-0048	21176B	18	26011-0961	26011A	52	34028-0350	34028C	30	39193-0583	39193A	13	43027-1053	43027	40

ÍNDICE NUMÉRICO DE REFERENCIAS

Parte N°	Fig No.	Pág No.	Parte N°	Fig No.	Pág No.	Parte N°	Fig No.	Pág No.	Parte N°	Fig No.	Pág No.	Parte N°	Fig No.	Pág No.
43028-1061	43028	38	44037-0171-21	44037	43	49034-0567	49034	19	55028-0624-45W	55028	57	59256-0554	59256	24
43028-1065	43028	40	44039-0169-18R	44039	43	49040-0758	49040	17	55028-0624-51P	55028A	57	59441-0043	59441	59
43034-0135	43034	41	44045-051	44045	43	49044-0015	49044	24	55028-0625	55028B	57	59441-0044	59441A	59
43034-1016	43034	38	44065-0030	44065	43	49047-0625	49047	11	55028-0626-45W	55028	58	59502-0611	59502	23
43044-0083	43044	39	44065-0036	44065A	43	49047-0626	49047A	11	55028-0626-51P	55028A	58	600A0500	600	10
43044-1112	43044	41	44071-1306-18R	44071	43	49054-1056	49054	24	55028-0627-45W	55028B	58	610A0406	610	11
43045-0004	43045	41	44071-1307-18R	44071A	43	49063-1055	49063	24	55028-0627-51P	55028C	58	670B2016	670	24
43045-1010	43045A	41	45014-0580-37S	45014	29	49065-0711	49065	19	55028-0628-45L	55028D	58	670B2018	670A	24
43048-0030	43048	39	46003-0696-18R	46003	42	49069-0825	49069	5	55028-0628-45W	55028E	58	670D2010	670	7
43048-1066	43048	41	46012-0010-18R	46012	42	49078-0077	49078	6	55028-0629-45L	55028F	58	670D2018	670	11
43049-1060	43049	39	46019-0060	46019	42	49085-0006	49085	23	55028-0629-45W	55028G	58	92001-1728	92001	38
43049-1061	43049A	39	46019-0070-18R	46019	27	49091-0001	49091	38	55028-0630	55028C	57	92001-1793	92001	8
43049-1063	43049	41	46019-0071-18R	46019A	27	49091-0001	49091	40	550AA2015	550	33	92001-1860	92001	40
43049-1064	43049A	41	46075-0564	46075	42	49106-0818	49106	5	550AA2015	550	40	92001-1905	92001	30
43056-0004	43056	39	46076-0143	46076	42	49118-0742	49118	7	550AA2525	550	37	92002-1323	92002	38
43056-0004	43056	41	46091-0352	46091	42	49118-0743	49118A	7	550AA4035	550	35	92002-1894	92002A	38
43057-1001	43057	39	46091-0353	46091A	42	51001-0843-45W	51001	44	550AA4035	550	36	92004-0040	92004	1
43057-1001	43057	41	46092-0571	46092	42	51001-0843-51P	51001A	44	554DA0600	554	27	92004-0048	92004	36
43058-1100	43058	39	46092-1203	46092	38	51044-0853	51044	17	56001-0299	56001	42	92005-0777	92005	24
43078-0040	43078	40	46098-016	46098	25	51049-0735	51049	44	56001-0300	56001A	42	92009-1134	92009	42
43078-0587	43078	23	46102-0573	46102	9	52005-1009	52005	15	56007-0157	56007	54	92009-1155	92009	57
43080-0126-DJ	43080	41	461DA0600	461	22	53003-0439-MA	53003	45	56054-1695	56054	62	92009-1197	92009	46
43080-0180-DJ	43080	39	461DA0600	461	53	53066-0547-MA	53066	45	56054-2239	56054	55	92009-1391	92009A	46
43082-0172	43082	41	482EA0100	482	30	53066-0566-MA	53066	66	56054-2239	56054	56	92009-1458	92009	38
43082-0173	43082	39	482EA5000	482A	30	54011-0622	54011	47	56054-2240	56054A	56	92009-1480	92009	60
43095-1445	43095	38	49002-0009	49002	1	54012-0650	54012	47	56054-2241	56054	60	92009-1654	92009	53
43095-1446	43095	40	49006-1088	49006	39	54012-0651	54012A	47	56054-2250	56054A	55	92015-1014	92015	57
43095-1449	43095A	40	49006-1088	49006	41	55020-0317	55020	28	56054-2261	56054B	55	92015-1197	92015	42
44005-0117-18R	44005	43	49006-1242	49006A	39	55020-1825	55020	62	56054-2261	56054B	56	92015-1233	92015	38
44006-0114-18R	44006	43	49006-1242	49006A	41	55020-1826	55020A	62	56071-0457	56071	60	92015-1364	92015	28
44013-0305	44013	43	49016-0627	49016	49	55020-1987	55020	53	56071-0724	56071A	60	92015-1367	92015	22
44023-0140	44023	43	49016-1044	49016	38	55020-1996	55020	43	57003-0152	57003	60	92015-1387	92015	5
44026-0210	44026	43	49016-1103	49016	40	55020-2174	55020	60	59051-0721	59051	19	92015-1415	92015	26
44029-1131	44029	43	49033-0558	49033	16	55020-2175	55020A	60	59051-0722	59051	22	92015-1476	92015A	22

ÍNDICE NUMÉRICO DE REFERENCIAS

Parte N°	Fig No.	Pág No.	Parte N°	Fig No.	Pág No.	Parte N°	Fig No.	Pág No.	Parte N°	Fig No.	Pág No.	Parte N°	Fig No.	Pág No.
92015-1527	92015	8	92028-1857	92028A	10	92045-0735	92045	10	92055-1354	92055	19	92072-0813	92072B	52
92015-1602	92015	32	92028-1858	92028B	10	92045-0826	92045	11	92055-1370	92055B	22	92072-1237	92072C	52
92015-1603	92015	59	92033-0079	92033	40	92045-1013	92045A	10	92055-1420	92055	43	92072-1293	92072	50
92015-1658	92015A	28	92033-015	92033	10	92046-0034	92046	15	92056-003	92056	43	92072-1293	92072D	52
92015-1700	92015	15	92033-026	92033A	10	92046-0607	92046	10	92057-0595	92057	7	92072-1414	92072E	52
92015-1946	92015B	28	92033-0732	92033	3	92046-0610	92046	28	92057-0647	92057	36	92072-1414	92072	53
92015-1963	92015	10	92033-0787	92033	47	92047-011	92047	25	92058-0037	92058	36	92072-1414	92072	62
92016-028	92016	9	92033-1040	92033	36	92047-012	92047	43	92066-0002	92066	1	92072-1414	92072	63
92022-1093	92022	50	92033-1186	92033A	40	92048-006	92048	25	92066-0003	92066	13	92075-015	92075	45
92022-1116	92022	9	92033-1222	92033	43	92048-008	92048A	25	92066-0748	92066	15	92075-015	92075	66
92022-112	92022	10	92037-1827	92037	44	92049-0125	92049	43	92066-0767	92066	19	92075-1002	92075	44
92022-1373	92022	41	92037-1827	92037	52	92049-0731	92049	13	92066-0785	92066	25	92075-1045	92075	27
92022-1380	92022	30	92038-001	92038	8	92049-0794	92049	35	92066-1110	92066A	13	92075-1045	92075	61
92022-1405	92022	46	92039-0707	92039	57	92049-0794	92049	36	92066-1184	92066	60	92075-1115	92075A	44
92022-1561	92022	37	92039-0709	92039	48	92049-1109	92049	29	92066-1220	92066	27	92075-1634	92075	58
92022-1582	92022	28	92039-3787	92039	64	92049-1254	92049	28	92066-1246	92066	11	92075-1690	92075	23
92022-161	92022A	10	92042-007	92042	1	92049-1349	92049	6	92066-1252	92066B	13	92081-076	92081	12
92022-1827	92022	12	92042-014	92042	19	92049-1559	92049A	13	92068-006	92068	16	92081-159	92081	22
92022-1827	92022	19	92042-031	92042	13	92049-1560	92049	15	92069-0050	92069	49	92081-1612	92081	30
92022-231	92022	43	92043-0104	92043	40	92055-0016	92055	18	92069-0090	92069	51	92081-1620	92081	16
92022-304	92022	3	92043-0746	92043	27	92055-0124	92055	16	92069-1016	92069A	49	92081-1737	92081	40
92026-0115	92026	9	92043-0820	92043	39	92055-0136	92055	22	92069-1016	92069	50	92090-007	92090	25
92026-0153	92026	22	92043-0907	92043	30	92055-0168	92055	37	92069-1084	92069A	50	92093-0035	92093	43
92026-0734	92026A	9	92043-0924	92043A	30	92055-0195	92055	2	92070-0031	92070	21	92093-0587	92093	23
92026-1217	92026	12	92043-1263	92043	15	92055-049	92055	15	92071-0705	92071	22	92093-0698	92093	4
92026-1276	92026	43	92043-1264	92043	1	92055-0728	92055	17	92071-0712	92071	5	92093-0699	92093A	4
92027-1183	92027	49	92043-1264	92043	3	92055-0732	92055	29	92071-0766	92071	32	92093-1030	92093	44
92027-1440	92027	12	92043-1309	92043	13	92055-0733	92055	13	92071-0766	92071	48	92104-0004	92104	54
92028-1422	92028	8	92043-132	92043	22	92055-0734	92055A	15	92071-0767	92071A	48	92104-1064	92104A	54
92028-1423	92028A	8	92043-1416	92043	41	92055-0735	92055	24	92071-0768	92071	58	92122-006	92122	22
92028-1424	92028B	8	92043-4009	92043	2	92055-0736	92055A	24	92071-0772	92071B	48	92122-0557	92122	19
92028-1564	92028	10	92045-0067	92045	9	92055-0741	92055	40	92072-0012	92072	16	92122-0557	92122	24
92028-1597	92028	29	92045-0732	92045	35	92055-1146	92055B	15	92072-0749	92072	52	92139-0773	92139	9
92028-1598	92028A	29	92045-0732	92045	36	92055-1276	92055A	22	92072-0807	92072A	52	92139-0782	92139	8

ÍNDICE NUMÉRICO DE REFERENCIAS

Parte N°	Fig No.	Pág No.	Parte N°	Fig No.	Pág No.	Parte N°	Fig No.	Pág No.	Parte N°	Fig No.	Pág No.	Parte N°	Fig No.	Pág No.
92139-0783	92139A	8	92151-1703	92151	48	92153-1774	92153	1	92154-1009	92154A	53	92154-2551	92154	43
92139-0784	92139B	8	92151-1986	92151	42	92153-1775	92153A	1	92154-1055	92154B	19	92154-2556	92154A	1
92139-0786	92139C	8	92152-0332	92152	44	92153-1810	92153	27	92154-1140	92154A	15	92154-2556	92154B	23
92139-0787	92139D	8	92152-0332	92152	60	92153-1851	92153	22	92154-1189	92154	14	92154-2557	92154E	24
92139-0788	92139E	8	92152-0658	92152	30	92153-1866	92153A	22	92154-1212	92154	24	92154-2558	92154	5
92139-0790	92139F	8	92152-0846	92152	23	92153-1872	92153	39	92154-1291	92154	31	92154-2559	92154A	11
92139-0791	92139G	8	92152-1545	92152A	30	92153-1886	92153	5	92154-1299	92154	42	92154-2560	92154C	13
92139-0792	92139H	8	92152-1562	92152	18	92153-1930	92153A	5	92154-1422	92154A	42	92154-2560	92154	38
92139-0793	92139	10	92152-2204	92152	62	92153-1986	92153	12	92154-1539	92154	33	92154-2560	92154	40
92139-0872	92139A	10	92152-2283	92152A	23	92154-0071	92154	15	92154-1547	92154A	32	92154-2561	92154B	11
92140-0008	92140	25	92152-2290	92152	35	92154-0175	92154	22	92154-1646	92154	39	92154-2561	92154C	19
92143-1016	92143	58	92152-2291	92152A	35	92154-0209	92154	48	92154-1773	92154B	15	92154-2832	92154A	14
92143-1251	92143	43	92152-2292	92152	36	92154-0209	92154	57	92154-1773	92154A	24	92160-1036	92160	12
92143-1968	92143	10	92152-2295	92152	5	92154-0209	92154	58	92154-1774	92154C	15	92160-1161	92160	29
92144-1074	92144	12	92152-2296	92152	15	92154-0235	92154	12	92154-1777	92154A	23	92160-1167	92160	46
92144-1847	92144	41	92152-2296	92152	32	92154-0246	92154	1	92154-1779	92154B	24	92160-1167	92160	49
92145-0144	92145	53	92152-2299	92152	33	92154-0359	92154	26	92154-2335	92154	17	92160-1167	92160	62
92145-0230	92145	37	92152-2302	92152	59	92154-0777	92154	13	92154-2339	92154	27	92160-1613	92160A	49
92145-0524	92145	39	92152-2314	92152A	59	92154-0784	92154	19	92154-2340	92154A	58	92161-0163	92161	50
92145-0656	92145	16	92152-2317	92152A	36	92154-0786	92154A	22	92154-2341	92154A	20	92161-0203	92161	52
92145-0723	92145	30	92152-234B	92152	31	92154-0807	92154	23	92154-2343	92154B	13	92161-0336	92161A	50
92145-1747	92145	12	92152-2350	92152	61	92154-0819	92154	7	92154-2346	92154D	15	92161-0685	92161	18
92145-1750	92145	9	92152-2352	92152	47	92154-0819	92154A	19	92154-2347	92154E	15	92161-0690	92161	24
92150-1301	92150	14	92153-0301	92153	43	92154-0917	92154A	48	92154-2349	92154C	24	92161-0691	92161A	24
92150-1548	92150A	14	92153-0531	92153	23	92154-0917	92154	62	92154-2351	92154D	24	92161-0776	92161B	50
92150-1577	92150	47	92153-0695	92153	24	92154-0918	92154	32	92154-2352	92154B	7	92161-0855	92161	45
92150-1684	92150	30	92153-0790	92153	59	92154-0932	92154A	57	92154-2355	92154B	32	92161-0855	92161	66
92150-1725	92150	7	92153-0793	92153	2	92154-0933	92154	53	92154-2359	92154A	59	92161-0927	92161	44
92151-1149	92151	28	92153-0927	92153	14	92154-0951	92154	59	92154-2509	92154A	26	92161-0927	92161	60
92151-1166	92151	41	92153-0967	92153	53	92154-0953	92154A	7	92154-2510	92154	29	92161-1367	92161	57
92151-1233	92151	3	92153-1267	92153	60	92154-0954	92154	11	92154-2511	92154A	29	92161-1424	92161	4
92151-1462	92151	14	92153-1526	92153	62	92154-0957	92154A	13	92154-2512	92154B	29	92161-1443	92161A	52
92151-1605	92151	31	92153-1625	92153A	43	92154-0962	92154	20	92154-2534	92154A	39	92161-1472	92161B	52
92151-1611	92151	62	92153-1632	92153A	14	92154-0997	92154	9	92154-2534	92154	41	92161-1497	92161	5

ÍNDICE NUMÉRICO DE REFERENCIAS

Parte N°	Fig No.	Pág No.	Parte N°	Fig No.	Pág No.	Parte N°	Fig No.	Pág No.	Parte N°	Fig No.	Pág No.	Parte N°	Fig No.	Pág No.
92161-1531	92161	32	92172-0427	92172	50	92173-1653	92173C	4	92192-1744	92192B	4	92210-0615	92210	41
92161-1531	92161	53	92172-0788	92172	42	92173-1654	92173	38	92192-1763	92192C	4	92210-0776	92210	49
92161-1685	92161	27	92172-0790	92172	18	92173-1670	92173	41	92200-0006	92200	57	92210-0784	92210	61
92161-1685	92161A	32	92172-0803	92172	4	92173-1714	92173D	4	92200-0006	92200	58	92210-0817	92210	32
92161-1685	92161A	45	92172-0812	92172	11	92173-1811	92173A	15	92200-0157	92200	31	92210-0817	92210	57
92161-1685	92161C	52	92172-0821	92172A	50	92173-1813	92173C	47	92200-0284	92200	50	92210-0858	92210	25
92161-1685	92161A	66	92172-0821	92172	57	92180-1014	92180	6	92200-0386	92200	22	92210-1171	92210	35
92161-1810	92161	15	92172-0821	92172	58	92180-1016	92180A	6	92200-0430	92200	32	92210-1171	92210A	36
92161-1883	92161A	27	92172-0864	92172A	57	92180-1018	92180B	6	92200-0434	92200	12	92210-1242	92210	5
92161-1883	92161A	44	92172-0864	92172	62	92180-1020	92180C	6	92200-0456	92200A	57	92210-1247	92210	29
92161-1909	92161D	52	92172-0904	92172B	50	92180-1022	92180D	6	92200-0766	92200	62	92210-1323	92210	23
92161-1910	92161A	60	92172-1117	92172	51	92180-1024	92180E	6	92200-0784	92200	48	92210-1397	92210	28
92161-1911	92161B	44	92172-1144	92172A	4	92180-1026	92180F	6	92200-0788	92200	14	92210-1518	92210A	23
92161-1911	92161A	57	92173-0028	92173	40	92180-1028	92180G	6	92200-0789	92200	23	92210-1564	92210	31
92161-1911	92161	58	92173-0049	92173	44	92180-1030	92180H	6	92200-0790	92200	20	99994-0992	99994	59
92161-1925	92161	39	92173-0050	92173	23	92180-1032	92180I	6	92200-0796	92200	4	99994-0993	99994	60
92161-1926	92161	42	92173-0190	92173	4	92180-1034	92180J	6	92200-0796	92200A	32	99994-0995	99994	61
92161-1930	92161A	42	92173-0192	92173A	4	92180-1036	92180K	6	92200-0851	92200	10	99994-0996	99994	62
92161-1935	92161	30	92173-0193	92173B	4	92180-1038	92180L	6	92200-0854	92200	51	99994-0997	99994	63
92161-1972	92161B	27	92173-0736	92173A	44	92180-1040	92180M	6	92200-0855	92200A	51	99994-0998	99994	64
92161-1985	92161	59	92173-0736	92173	51	92180-1042	92180N	6	92200-0860	92200	1	99994-1000	99994	65
92161-1992	92161A	4	92173-0736	92173	53	92180-1044	92180O	6	92200-1389	92200A	10	99994-1002	99994	66
92161-2070	92161	48	92173-0833	92173	15	92180-1046	92180P	6	92200-1762	92200	59	99994-1004	99994	67
92170-1017	92170	4	92173-0861	92173	24	92180-1048	92180Q	6	92200-1842	92200	35	99999-0524	99999	17
92170-1091	92170	40	92173-0868	92173	52	92180-1050	92180R	6	92200-1842	92200	36	MF12V9-1A-AUTECO	26012	52
92171-0059	92171	5	92173-0919	92173	1	92180-1052	92180S	6	92200-1853	92200A	23	YTX9-BS-GEL-AUTECO		52
92171-0640	92171	41	92173-0942	92173	5	92180-1054	92180T	6	92200-1857	92200	11			
92171-0939	92171	53	92173-0956	92173A	1	92192-0225	92192	13	92200-1858	92200	25			
92171-1184	92171	23	92173-1386	92173	42	92192-0910	92192	44	92200-1890	92200B	57			
92171-1703	92171A	41	92173-1416	92173A	24	92192-1170	92192	16	92200-1892	92200	30			
92172-0064	92172	16	92173-1417	92173B	24	92192-1528	92192	49	92210-0006	92210	42			
92172-0129	92172A	16	92173-1629	92173	47	92192-1727	92192	4	92210-0007	92210	18			
92172-0262	92172	52	92173-1630	92173A	47	92192-1728	92192A	4	92210-0007	92210	53			
92172-0334	92172	22	92173-1631	92173B	47	92192-1732	92192A	44	92210-0276	92210	36			

FICHA TÉCNICA VERSIS-X 250

CARACTERÍSTICA	UNIDAD
Motor	4T, 2 Cilindros, DOHC
Cilindrada	249 cc
Diámetro x Carrera	62.0 x 41.2 mm
Indicé de Compresión	11.3:1
Potencia Máxima	33 HP @ 11500 RPM
Torque Máximo	21.7 Nm @ 10000 RPM
Bujía	NGK CR8E
Arranque	Eléctrico
Transmisión	Mecánica 6 Velocidades
Sistema de Alimentación	Inyección Electrónica
Sistema de Lubricación	Forzada, Cártér Húmedo
Sistema de Ignición	Batería y Bobina (Transistorizado)
Refrigeración	Líquido
FRENOS	
Freno Delantero	Disco (290 mm)
Freno Trasero	Disco (220 mm)
CAPACIDAD DEL TANQUE	
Lleno	17 litros (4,49 Galones)
Combustible	Extra
LLANTAS	
Llanta Delantera	100/90-19M/C 57S
Llanta Trasera	130/80-17M/C 65S
Rines	Radios
SUSPENSION	
Suspensión Delantera	Telescópica Hidráulica
Suspensión Trasera	Monoamortiguador
SISTEMA ELECTRICO	
Bombillos Farola	12V 60/55 W
Luz de Stop	12V 21/5 W
Luces Direccionales	12V 10 W
Velocímetro	LED
Pito	12 VDC
Batería	12V 8AH
DIMENSIONES	
Largo x Ancho x Alto	2170 mm x 860 mm x 1390 mm
Distancia Entre Ejes	1450 mm.
Altura al Piso	180 mm.
Peso en Seco	173 kg

VERSYS-X 250





Línea Gratuita Nacional
01 8000 52 00 90
servicioalcliente@auteco.com.co
www.auteco.com.co

