



# **CATÁLOGO DE PARTES**

## *MOTO ELÉCTRICA - SHIPPER ST*

[www.starker.com.co](http://www.starker.com.co)

**¡ENERGIZA TU VIDA!**

**#LANUEVAENERGÍA**

# NUESTRAS TIENDAS

Auteco electric esta energizando a Colombia desde sus tiendas, encuentra mayor información en la línea **01 8000 520090** y en el sitio web **[www.starker.com.co](http://www.starker.com.co)**

- 📍 Bogotá - Av las Américas # 68F - 57
- 📍 Bogotá - Av carrera 19 # 134 -65
- 📍 Bogotá - Av calle 80 # 82 A - 22
- 📍 Bogotá - Carrera 96 # 140 D - 13
- 📍 Medellín - Calle 37 # 50 - 9
- 📍 Palmira - Valle Carrera 28 # 28 - 37
- 📍 Cali - Valle Carrera 66 # 9 - 71

Starker

# # LaNuevaEnergía





# NUESTROS CENTROS DE SERVICIO AUTORIZADOS

Auteco electric esta energizando  
a Colombia desde sus tiendas,  
encuentra mayor información  
en la línea 01 8000 520090  
y en el sitio web [www.starker.com.co](http://www.starker.com.co)

- 📍 Bogotá - Av Calle 80 # 82 A - 22
- 📍 Bogotá - Av Carrera 19 # 134 - 65
- 📍 Medellín - Calle 38 # 52 - 34 (la bayadera)
- 📍 Palmira - Valle Carrera 28 # 28 - 37
- 📍 Cali - Valle Carrera 1 # 23 - 40



  
auteco<sup>®</sup>  
electric

 starker  
Energize Your Life



---

## PREFACIO

---

Es nuestro placer presentarles a ustedes el Catálogo de Partes.

Este Catálogo ha sido especialmente diseñado para ayudarle en la selección de las partes correctas con el fin de mantener el vehículo en las mejores condiciones.

Los repuestos originales están sujetos a un exigente estándar de control de calidad, por lo tanto es necesario que usted sólo use repuestos originales.

En nuestro constante esfuerzo para mejorar la eficiencia y desempeño de su vehículo, las especificaciones, diagramas y número de partes pueden cambiar sin previo aviso. Consecuentemente las descripciones de los repuestos en este Catálogo pueden no ser las finales y definitivas.



Las alteraciones y modificaciones que ocurren en la impresión de este Catálogo, serán informadas a nuestra red, a través de circulares de Servicio o en nuestra página web: [www.auteco.com.co](http://www.auteco.com.co) accediendo al link repuestos. Es requisito que usted actualice su Catálogo y haga las correcciones necesarias, una vez reciba dichas circulares. Lo anterior le asegurará un rápido y adecuado despacho de sus partes, pues las órdenes están siendo diligenciadas con las referencias más actualizadas.

En caso de necesitar asistencia técnica, comunicarse con el Distribuidor Autorizado o llamar al Departamento de Servicios Auteco.

# ÍNDICE

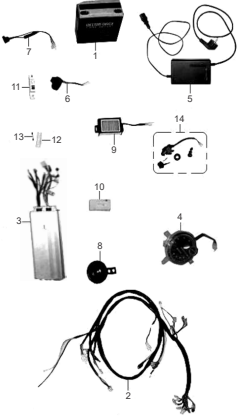
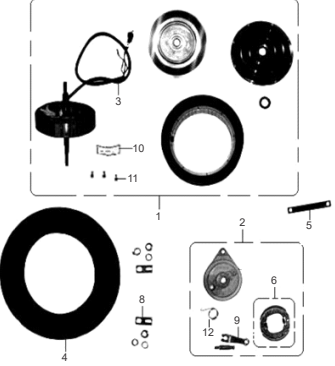
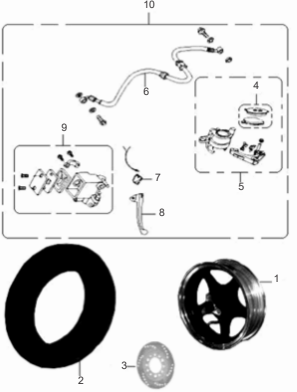

DESCRIPCIÓN	PÁG. N°
SISTEMA ELÉCTRICO .....	1
RUEDA TRASERA - MOTOR .....	2
RUEDA DELANTERA .....	3
CHASIS .....	4
SUSPENSIÓN DELANTERA .....	5
SUSPENSIÓN TRASERA .....	6
MANUBRIO .....	7
LUCES .....	8
PARTES PLÁSTICAS .....	9
GUARDABARROS Y TAPAS .....	10
PARRILLAS Y SOPORTES .....	11
INDICE DE REFERENCIAS .....	12

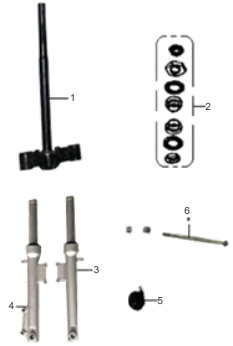
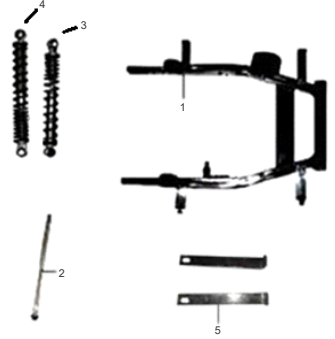
## ÍNDICE DE GRÁFICOS

					
<p><b>FIGURA N° 1: SISTEMA ELÉCTRICO</b></p>	<p><b>PAG 1</b></p>	<p><b>FIGURA N° 2: RUEDA TRASERA - MOTOR</b></p>	<p><b>PAG 2</b></p>	<p><b>FIGURA N° 3: RUEDA DELANTERA</b></p>	<p><b>PAG 3</b></p>
					
<p><b>FIGURA N° 4: CHASIS</b></p>	<p><b>PAG 4</b></p>	<p><b>FIGURA N° 5: SUSPENSIÓN DELANTERA</b></p>	<p><b>PAG 5</b></p>	<p><b>FIGURA N° 6: SUSPENSIÓN TRASERA</b></p>	<p><b>PAG 6</b></p>

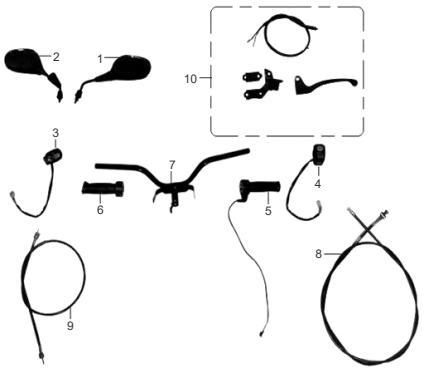
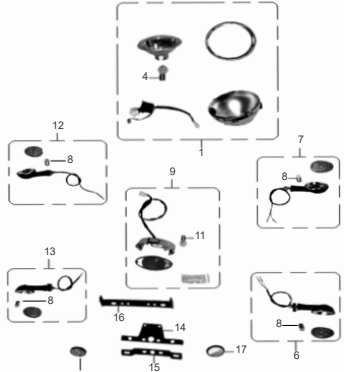

## ÍNDICE DE GRÁFICOS

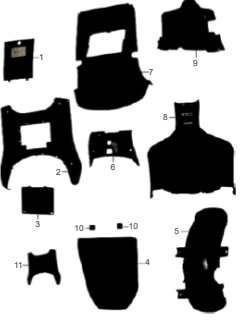
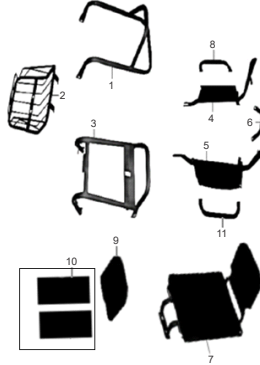
			
<b>FIGURA N° 7: MANUBRIO</b>	<b>PAG 7</b>	<b>FIGURA N° 8: LUCES</b>	<b>PAG 8</b>
			
<b>FIGURA N° 10: GUARDABARROS Y TAPAS</b>	<b>PAG 10</b>	<b>FIGURA N° 11: PARRILLAS Y SOPORTES</b>	<b>PAG 11</b>

**FIGURA N° 01: SISTEMA ELÉCTRICO**

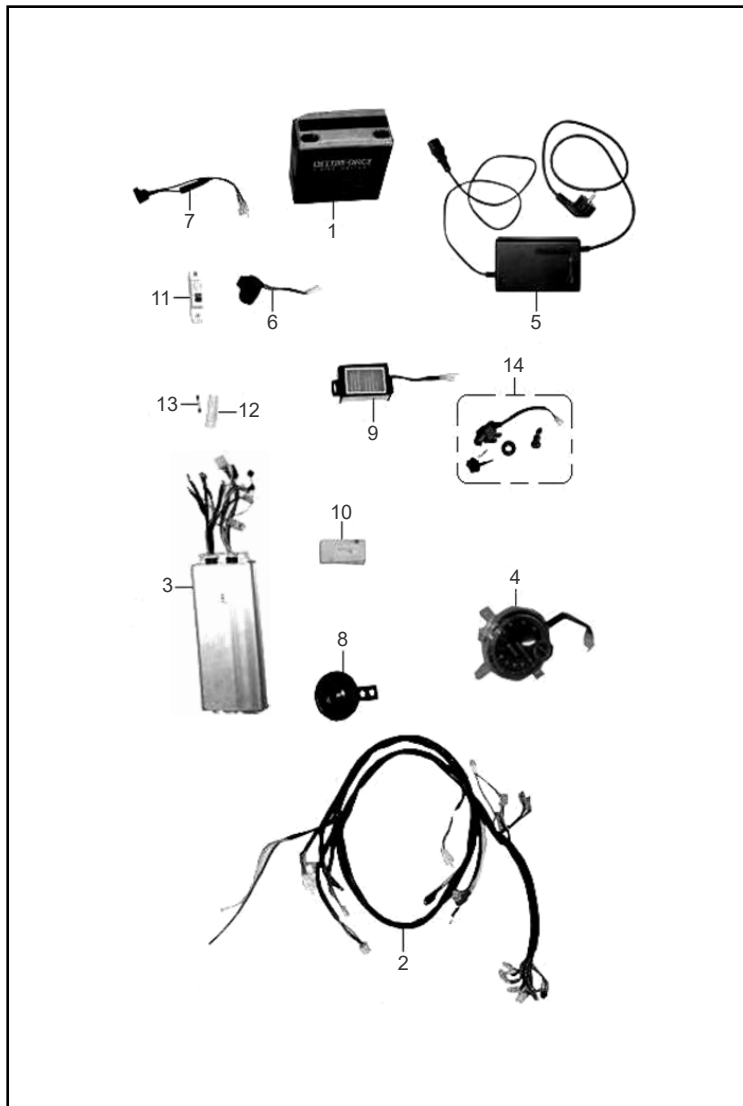

FIG. No.	PARTE No.	DESCRIPCIÓN	CANT. VEH.	OBSERVACIÓN
1	L1200000035	Set x 5 Batería 12V/24AH	1	
	L1200000035-1	Batería 12V/24AH	5	Individual
2	L1070000053	Ramal	1	
3	L1120000118	Controlador	1	
4	L7230000002	Velocímetro	1	
5	L1280000203	Cargador	1	
6	L1130000003	Flasher	1	
7	L1170000027	Toma de Carga	1	
8	L7210000013	Pito	1	
9	L1040000009	Convertidor	1	
10	L1340000022	Caja de Conexiones	1	
11	L1210000012	Breaker	1	
12	L1100000003	Caja de Fusible	1	
13	L1330000013	Fusible	1	
14	L1290000002	Kit Switch	1	
15	L1180000010	Cable Conexion Bateria	4	No Ilustrado
16	N0000003086	Antivibrante Bateria	1	No Ilustrado

FIGURA N° 02: RUEDA TRASERA - MOTOR

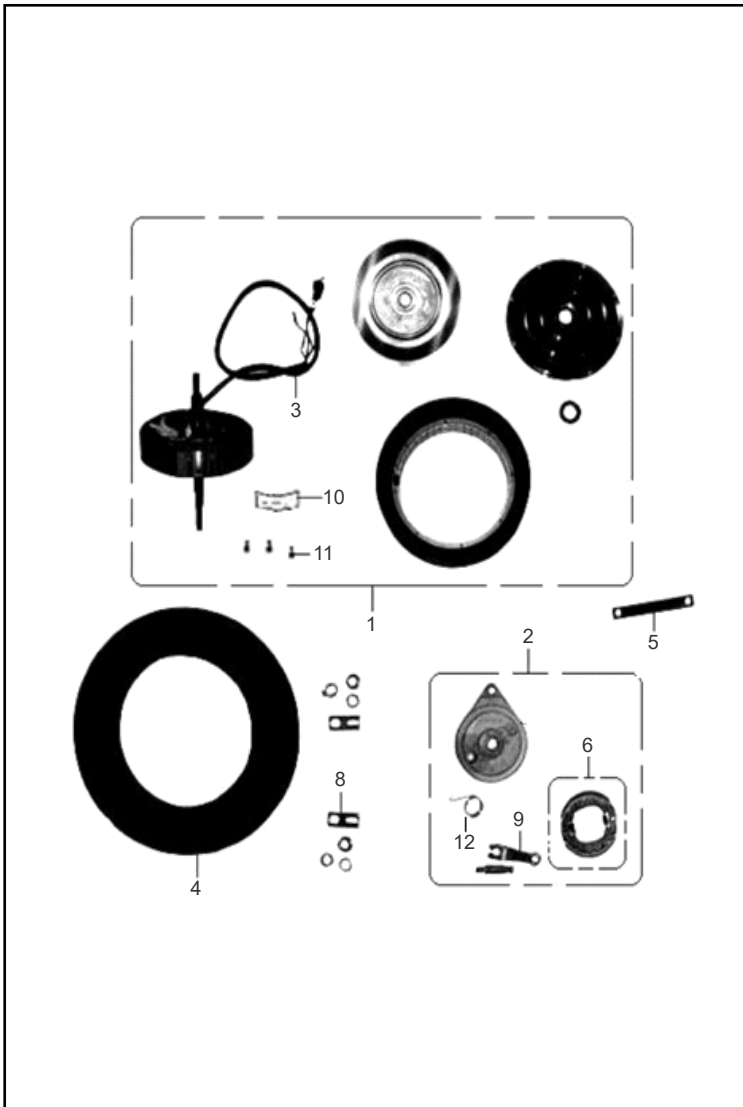

FIG. No.	PARTE No.	DESCRIPCIÓN	CANT. VEH.	OBSERVACIÓN
1	L1020000175	Motor con Porta Bandas	1	
2	L1020100007	Porta Bandas Completo	1	
3	L1070001299	Cable Motor	1	
4	L6030000012	Llanta 3.00-10	1	
5	L3140000002	Platina Porta Bandas	1	
6	L6080200006	Bandas Freno	1	
8	L1330000014	Platina Ajuste Motor	2	
9	L1010100006	Leva Porta Bandas Tras.	1	
10	L1020900021	Platina	1	
11	L1020400003	Sensor Hall	3	
12	L1020900025	Resorte	1	



**FIGURA N° 03: RUEDA DELANTERA**

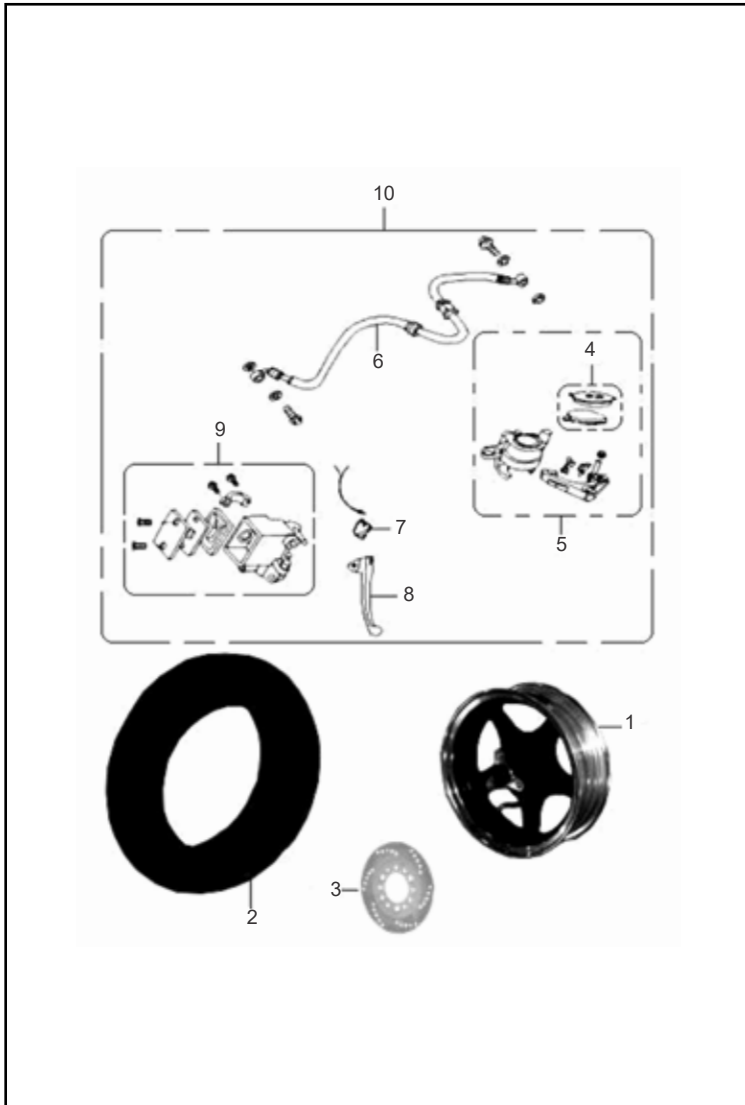

FIG. No.	PORTE No.	DESCRIPCIÓN	CANT. VEH.	OBSERVACIÓN
1	L6110000021	Rin Delantero	1	
2	L6030000012	Llanta 3.00-10	1	
3	L6090000220	Disco de Freno	1	
4	L6080300007	Pastas de Freno	1	
5	L6070500190	Caliper	1	
6	L6070700040	Conducto Bomba Freno	1	
7	L9510000441	Sensor	1	
8	L6120000151	Leva Freno Delantero	1	
9	L6070600099	Bomba de Freno Delantero	1	
10	L6070000245	Sistema de Freno Del. Completo	1	

FIGURA N° 04: CHASIS

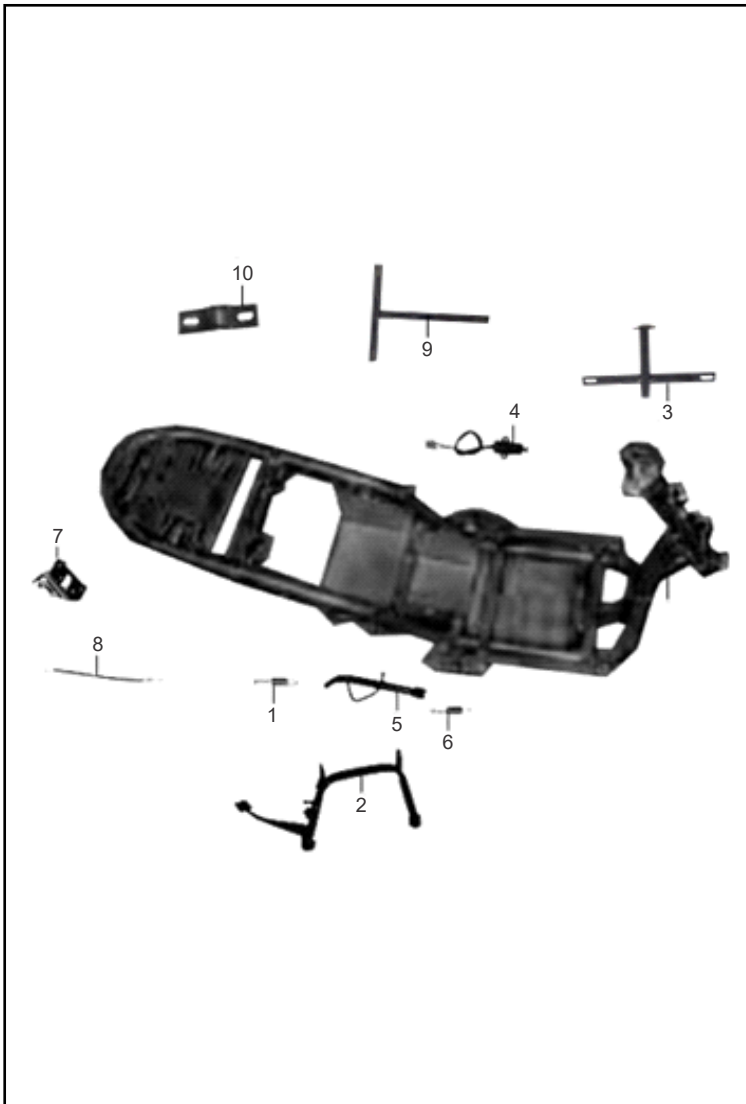

FIG. No.	PARTE No.	DESCRIPCIÓN	CANT. VEH.	OBSERVACIÓN
1	L9300000049	Resorte Doble 2.0x95	1	
2	L3050000024	Gato Central	1	
3	T1000946000	Varilla Fijación de Batería A	1	
4	L1140100006	Sensor Gato Lateral	1	
5	L3070000002	Gato Lateral	1	
6	L9300000050	Resorte Doble 2.0x100	1	
7	L3170000048	Seguro Sillín	1	
8	L4090000049	Cable Seguro Sillín	1	
9	T1000947000	Soporte Fijación Batería	1	
10	L8070000013	Platina	1	

FIGURA N° 05: SUSPENSIÓN DELANTERA

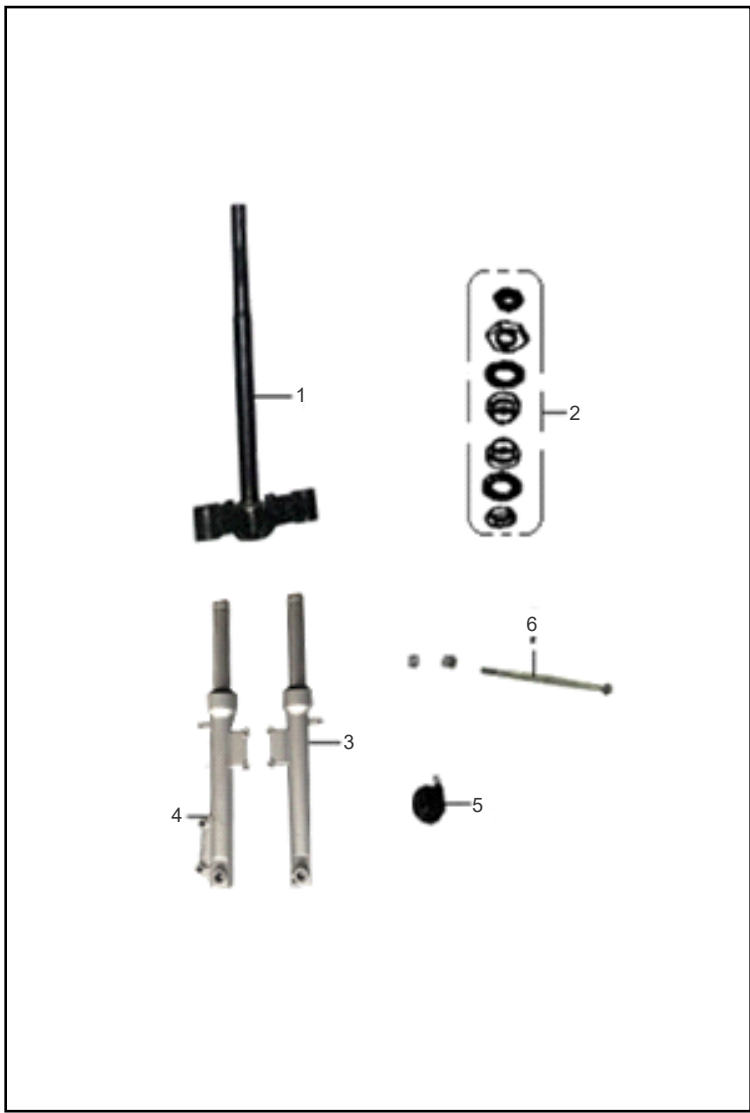

FIG. No.	PARTE No.	DESCRIPCIÓN	CANT. VEH.	OBSERVACIÓN
1	L3200300002	Espiga	1	
2	L4010000002	Kit Cunas	1	
3	L3200200398	Suspensión Derecha	1	
4	L3200100015	Suspensión Izquierda	1	
5	L6020000008	Caja Piñón Velocimetro	1	
6	L6010000241	Eje Delantero	1	





FIGURA N° 07: MANUBRIO

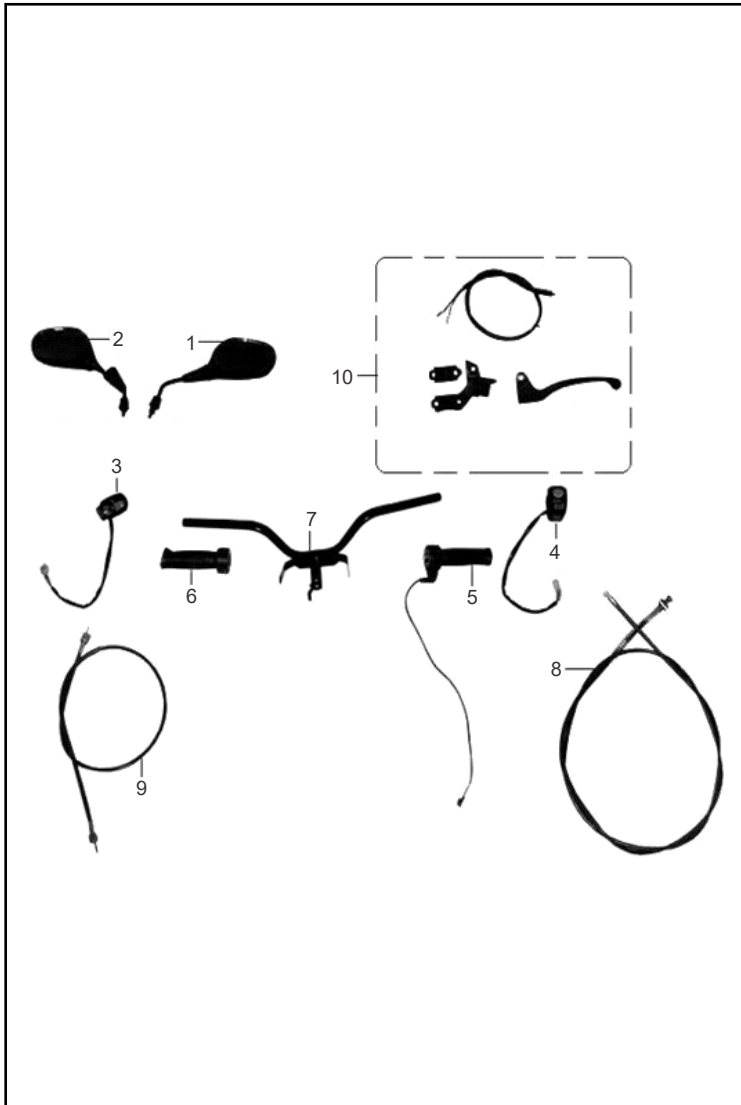

FIG. No.	PORTE No.	DESCRIPCIÓN	CANT. VEH.	OBSERVACIÓN
1	L8140000004	Espejo Izquierdo	1	
2	L8150000003	Espejo Derecho	1	
3	L1060100091	Comando Izquierdo	1	
4	L1060000008	Comando Derecho	1	
5	L1360000334	Manillar Acelerador	1	
6	L1350000201	Manillar Izquierdo	1	
7	L4030000031	Manubrio	1	
8	L6150000077	Cable de Freno Trasero	1	
9	L7250000026	Cable Kilometraje	1	
10	L6130000086	Leva Izquierda Completa	1	
11	L6120000151	Leva Freno Delantero	1	No Ilustrado

FIGURA N° 08: LUCES

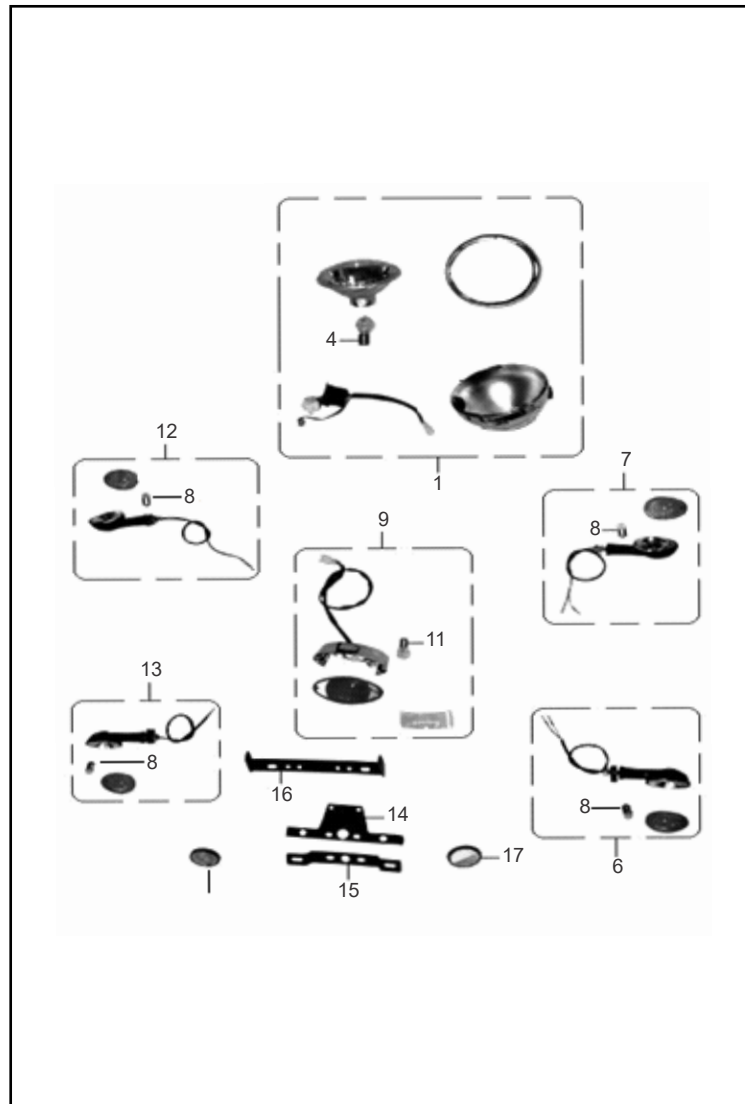

FIG. No.	PARTE No.	DESCRIPCIÓN	CANT. VEH.	OBSERVACIÓN
1	L7010000506	Farola Completa	1	
3	L7010100040	Bombillo Antiniebla	1	No Ilustrado
4	L7010100041	Bombillo	1	
6	L7060000077	Direccional Trasera Der.	1	
7	L7040000204	Direccional Delantera Der.	1	
8	L7010100042	Bombillo Direccionales	4	
9	L7070000014	Stop	1	
11	L7010100043	Bombillo Stop	1	
12	L7030000207	Direccional Delantera Izq.	1	
13	L7050000077	Direccional Tras. Izquierda	1	
14	L3150000001	Soporte Luz Stop	1	
15	L3100000003	Soporte Placa	1	
16	L3320000001	Soporte Reflector	1	
17	L7200000004	Reflectivo Trasero	1	
18	L7190000002	Reflectivo Lateral	2	No Ilustrado

**FIGURA N° 09: PARTES PLÁSTICAS**

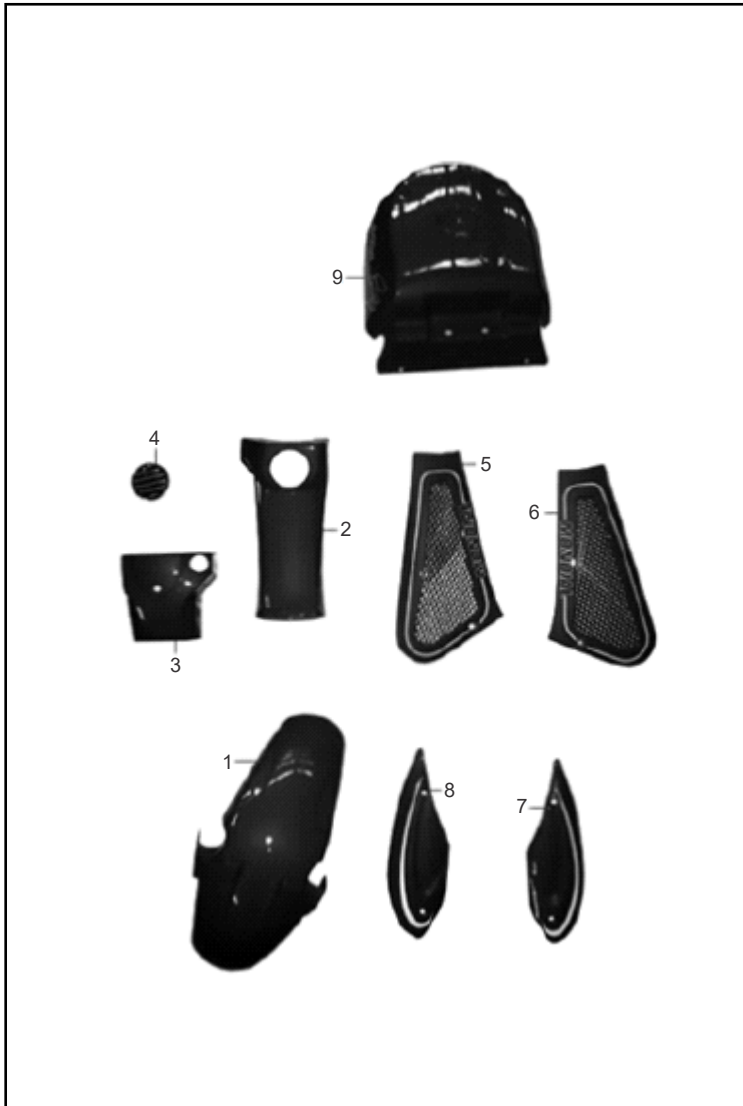

FIG. No.	PORTE No.	DESCRIPCIÓN	CANT. VEH.	OBSERVACIÓN
1	C1005885000	Guardabarro Delantero	1	
2	C1005883000	Cubierta Frontal	1	
3	C1005884000	Cubierta Interna	1	
4	C2005082000	Placa Cubierta Frontal	1	
5	C1005888000	Cubierta Sillín Izquierda	1	
6	C1005889000	Cubierta Sillín Derecha	1	
7	C1005886000	Cubierta Lateral Inf. Izq.	1	
8	C1005887000	Cubierta Lateral Inf. Der.	1	
9	C1005890000	Cubierta Inferior Sillín	1	
10	L8240000939	Calcomanía "STARKER" 3D	1	No Ilustrado

FIGURA N° 10: GUARDABARROS Y TAPAS

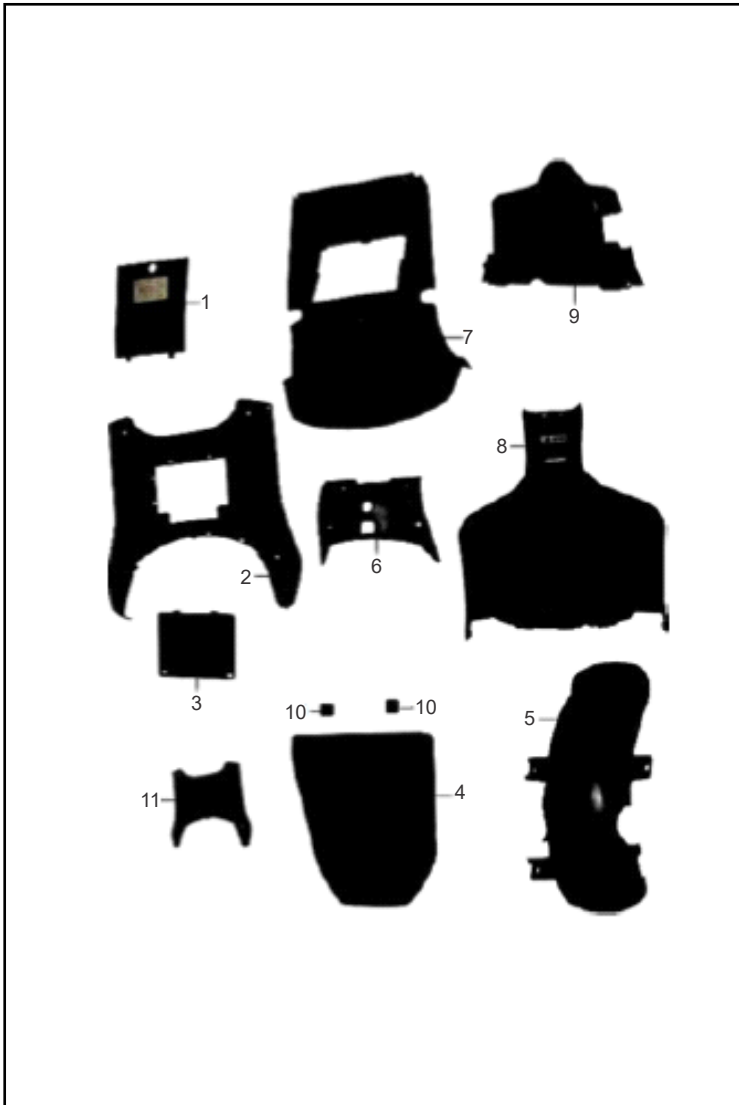

FIG. No.	PARTE No.	DESCRIPCIÓN	CANT. VEH.	OBSERVACIÓN
1	C2005084000	Tapa Interior Caja Guanterera	1	
2	C2005337000	Piso	1	
3	C2005083000	Tapa piso	1	
4	L8010000736	Sillín	1	
5	C2005335000	Guardabarro Trasero Interno	1	
6	C2005339000	Cubierta Frontal Caja Guanterera	1	
7	C2005338000	Cubierta Central	1	
8	C2005336000	Carenaje Interno	1	
9	C2000363000	Guardabarro inferior	1	
10	L9510000389	Antivibrante Sillín	2	
11	L8200000251	Tapete Piso	1	

FIGURA N° 11: PARRILLAS Y SOPORTES

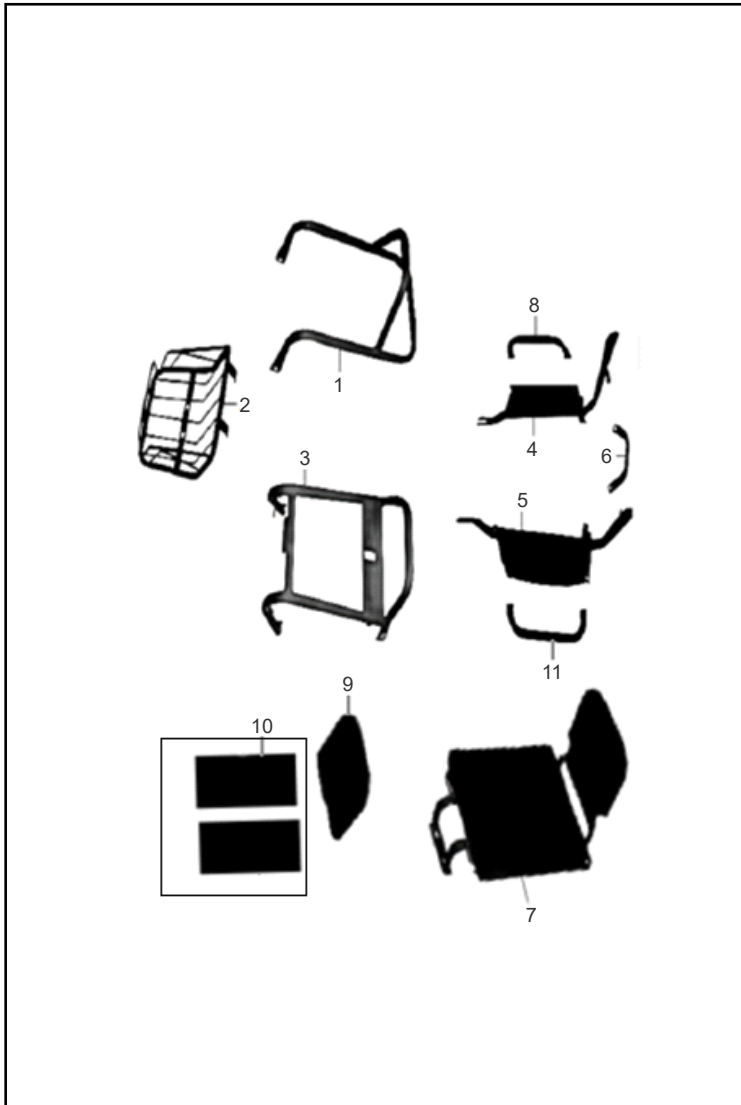

FIG. No.	PARTE No.	DESCRIPCIÓN	CANT. VEH.	OBSERVACIÓN
1	L8070000001	Soporte Sillín	1	
2	L8060000408	Canasta	1	
3	L3300000001	Soporte Sillín	1	
4	T1000710000	Reposapie Derecho	1	
5	T1000709000	Reposapie Izquierdo	1	
6	L3140000072	Soporte de Sujeción	1	
7	L3240000006	Base Sillín Trasero	1	
8	T1000716000	Parrilla de Carga Derecha	2	
9	L8050000294	Espaldar Parrillero	1	
10	L8010000742	Asistente de Asiento Trasero	2	
11	T1000711000	Parrilla de Carga Izquierda	1	
12	L8200000254	Tapete Reposapiés Izq. Y Der.	2	No Ilustrado
13	L9300000112	Resorte Reposapie	2	No Ilustrado
14	L8270001638	Kit Calcomanías Shipper St Negro/Verde	1	No Ilustrado
15	L8270001637	Kit Calcomanías Shipper St Blanco/Negro	1	No Ilustrado
16	L8240000984	CALCOMANIA AVISO	1	No Ilustrado

## ÍNDICE DE REFERENCIAS

PARTE No.	FIG. No.	PAG. No.
C1005883000	2	9
C1005884000	3	9
C1005885000	1	9
C1005886000	7	9
C1005887000	8	9
C1005888000	5	9
C1005889000	6	9
C1005890000	9	9
C2000363000	9	10
C2005082000	4	9
C2005083000	3	10
C2005084000	1	10
C2005335000	5	10
C2005336000	8	10
C2005337000	2	10
C2005338000	7	10
C2005339000	6	10
L1010100006	9	2
L1020000175	1	2
L1020100007	2	2
L1020400003	11	2
L1020900021	10	2
L1020900025	12	2
L1040000009	9	1
L1060000008	4	7

PARTE No.	FIG. No.	PAG. No.
L1060100091	3	7
L1070000053	2	1
L1070001299	3	2
L1100000003	12	1
L1120000118	3	1
L1130000003	6	1
L1140100006	4	4
L1170000027	7	1
L1180000010	15	1
L1200000035	1	1
L1200000035-1	1	1
L1210000012	11	1
L1280000203	5	1
L1290000002	14	1
L1330000013	13	1
L1330000014	8	2
L1340000022	10	1
L1350000201	6	7
L1360000334	5	7
L3040000017	1	6
L3050000024	2	4
L3070000002	5	4
L3080000004	5	6
L3100000003	15	8
L3140000002	5	2

PARTE No.	FIG. No.	PAG. No.
L3140000072	6	11
L3150000001	14	8
L3170000048	7	4
L3200100015	4	5
L3200200398	3	5
L3200300002	1	5
L3210000002	4	6
L3210000005	3	6
L3240000006	7	11
L3300000001	3	11
L3320000001	16	8
L4010000002	2	5
L4030000031	7	7
L4090000049	8	4
L6010000241	6	5
L6020000008	5	5
L6030000012	4	2
L6030000012	2	3
L6070000245	10	3
L6070500190	5	3
L6070600099	9	3
L6070700040	6	3
L6080200006	6	2
L6080300007	4	3
L6090000220	3	3

PARTE No.	FIG. No.	PAG. No.
L6110000021	1	3
L6120000151	8	3
L6120000151	11	7
L6130000086	10	7
L6150000077	8	7
L7010000506	1	8
L7010100040	3	8
L7010100041	4	8
L7010100042	8	8
L7010100043	11	8
L7030000207	12	8
L7040000204	7	8
L7050000077	13	8
L7060000077	6	8
L7070000014	9	8
L7190000002	18	8
L7200000004	17	8
L7210000013	8	1
L7230000002	4	1
L7250000026	9	7
L8010000736	4	10
L8010000742	10	11
L8050000294	9	11
L8060000408	2	11
L8070000001	1	11

PARTE No.	FIG. No.	PAG. No.
L8070000013	10	4
L8140000004	1	7
L8150000003	2	7
L8200000251	11	10
L8200000254	12	11
L8240000939	10	9
L8240000984	16	11
L8270001637	15	11
L8270001638	14	11
L9280000058	2	6
L9300000049	1	4
L9300000050	6	4
L9300000112	13	11
L9510000389	10	10
L9510000441	7	3
N0000003086	16	1
T1000709000	5	11
T1000710000	4	11
T1000711000	11	11
T1000716000	8	11
T1000946000	3	4
T1000947000	9	4



## FICHA TÉCNICA SHIPPER ST

CARACTERÍSTICAS	UNIDAD
Tipo Motor :	Motor HUB DC Sin Escobillas
Potencia Motor :	1200W
Velocidad Máxima :	45Km/h
Autonomía :	55Km
Suspensión Delantera :	Telescópica Hidráulica
Suspensión Trasera :	Doble Amortiguador Lateral (4 Amortiguadores)
<b>FRENOS</b>	
Freno Delantero :	Disco
Freno Trasero :	Campana
<b>LLANTAS</b>	
Llanta Delantera :	3.00-10 TL (Sin Neumático)
Llanta Trasera :	3.00-10 TL (Sin Neumático)
Rines :	Aspa
<b>SISTEMA ELÉCTRICO</b>	
Batería :	60V/24AH
Tiempo de Carga :	6-8 h
Tablero de Información :	Si
Tipo de Batería :	Pb Plomo-Ácido
Batería Removible (Si/No) :	No
<b>DIMENSIONES</b>	
Largo :	1830 mm
Ancho :	890 mm
Altura :	1250 mm
Peso en Seco (kg) :	103 Kg



# stärker MOTO ELÉCTRICA SHIPPER ST





 **stärker**<sup>®</sup>  
Energize Your Life |



[www.auteco.com.co](http://www.auteco.com.co)

Línea gratuita nacional: 018000 520090

