



ELIMINATOR
175 c.c.

Catálogo de Partes

PREFACIO

Es nuestro placer presentarles a ustedes el Catálogo de Partes.

Este Catálogo ha sido especialmente diseñado para ayudarle en la selección de las partes correctas con el fin de mantener el vehículo en las mejores condiciones.

Los repuestos originales están sujetos a un exigente estándar de control de calidad, por lo tanto es necesario que usted sólo use repuestos originales.

En nuestro constante esfuerzo para mejorar la eficiencia y desempeño de su vehículo, las especificaciones, diagramas y número de partes pueden cambiar sin previo aviso. Consecuentemente las descripciones de los repuestos en este Catálogo pueden no ser las finales y definitivas.

Las alteraciones y modificaciones que ocurran en la impresión de este catálogo, serán informadas a nuestra red, a través de circulares de Servicio. Es requisito que usted actualice su Catálogo y haga las correcciones necesarias, una vez reciba dichas circulares. Lo anterior le asegurará un rápido y adecuado despacho de sus partes, pues las órdenes están siendo diligenciadas con las referencias más actualizadas.

En caso de necesitar asistencia técnica, comunicarse con el Distribuidor Autorizado o llamar al Departamento de Servicios Auteco-Kawasaki.



BN175-A2/A3

**Motorcycle
Parts Catalog**

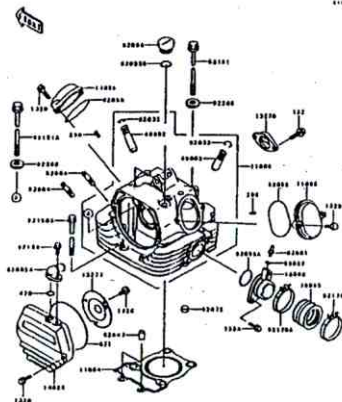

B-3 Cylinder Head

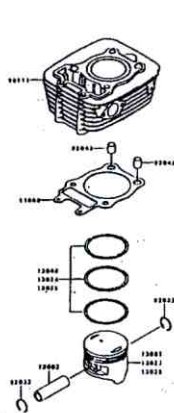

B-4 Cylinder/Piston(s)

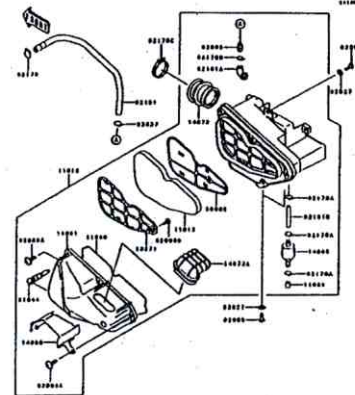

B-5 Air Cleaner

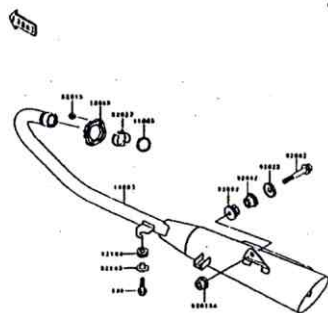

B-6 Muffler(s)

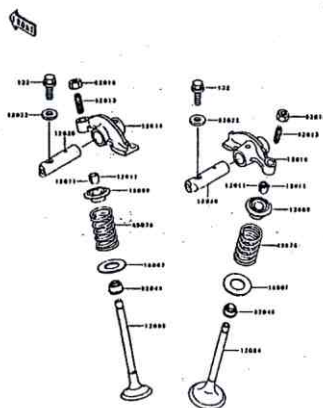

B-7 Valve(s)

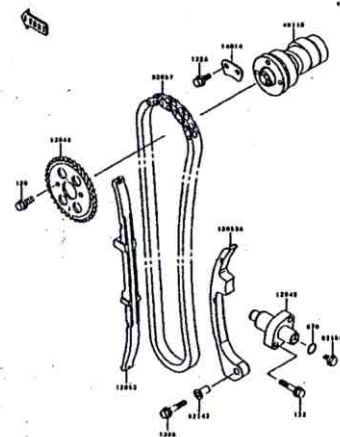

B-8 Camshaft(s)/Tensioner

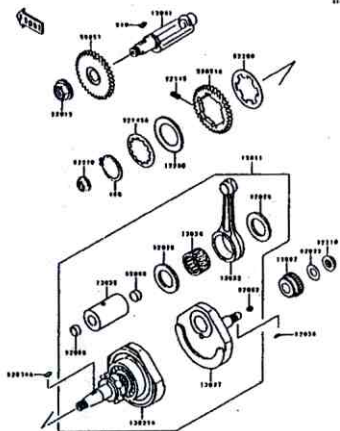

B-9 Crankshaft

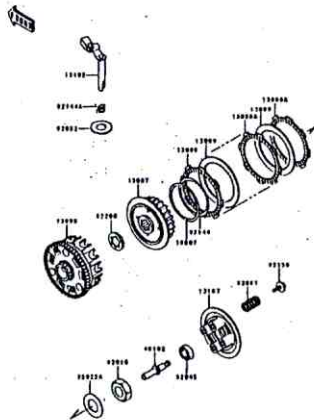

B-10 Clutch

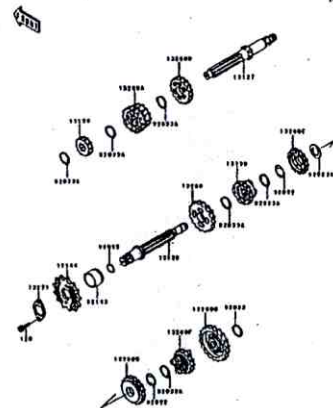

B-11 Transmission

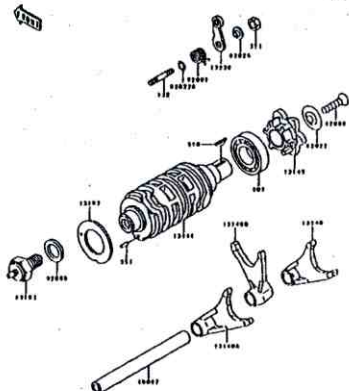

B-12 Gear Change Drum/Shift Fork(s)

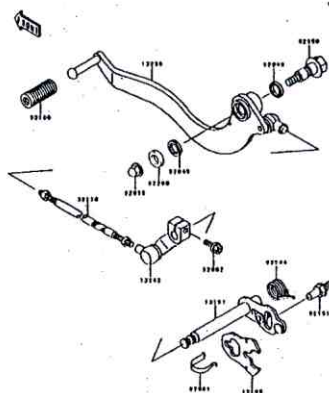

B-13 Gear Change Mechanism

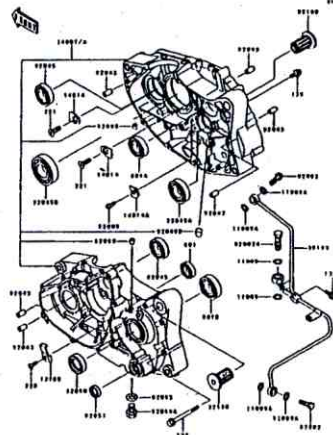

B-14 Crankcase

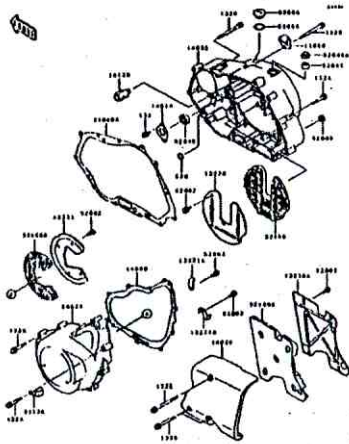

C-3 Engine Cover(s)

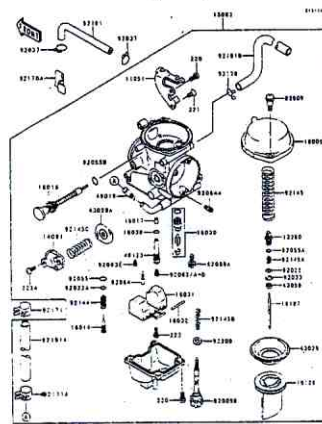

C-6 Carburetor(1/2)(BN175-A3)

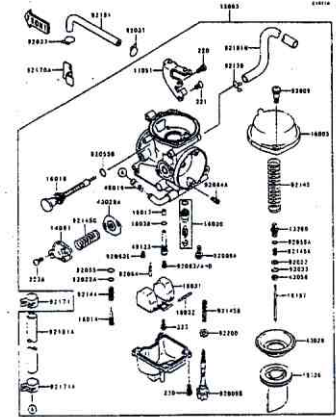

C-7 Carburetor(2/2)(BN175-A3)

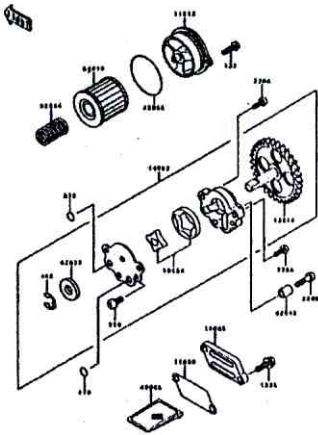

C-8 Oil Pump

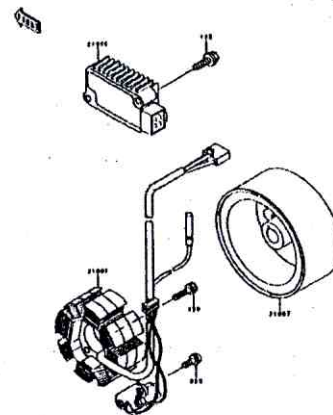

C-9 Generator

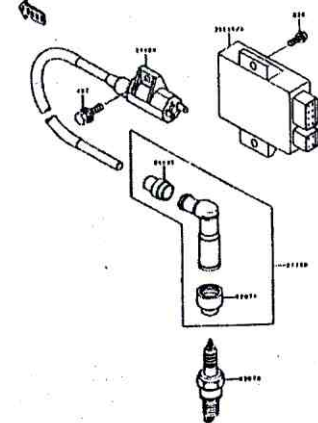

C-10 Ignition System

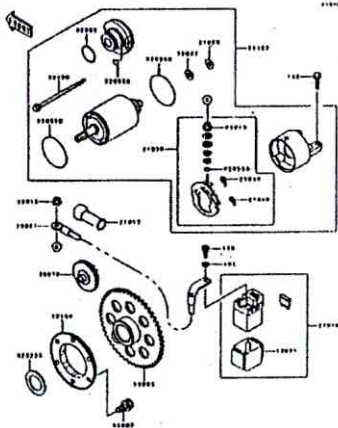

C-11 Starter Motor

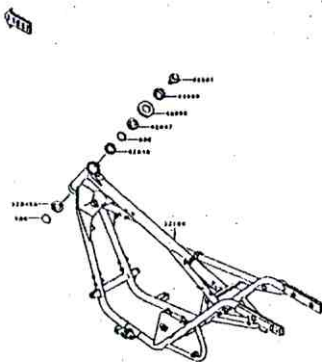

D-3 Frame

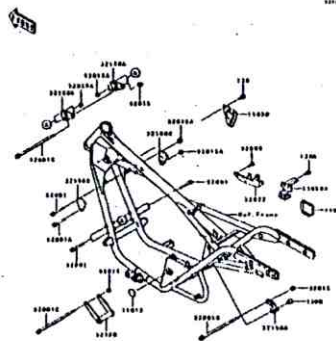

D-4 Frame Fittings

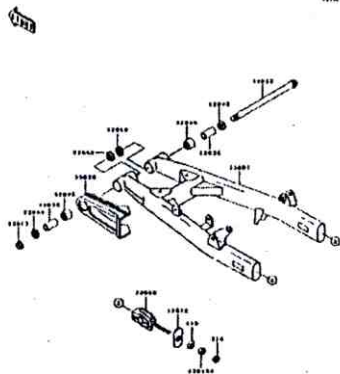

D-5 Swingarm

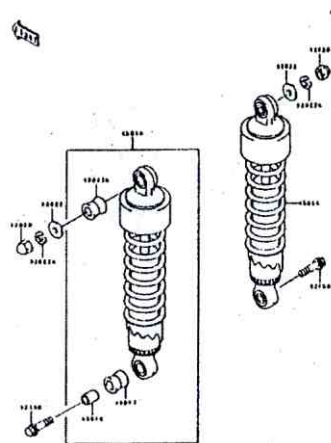

D-6 Suspension/Shock Absorber

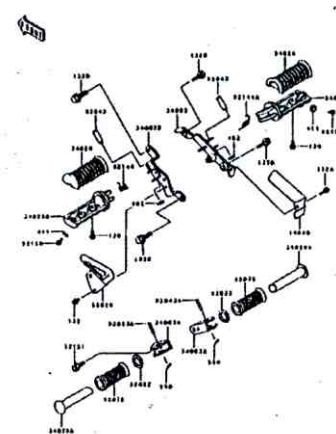

D-7 Footrests

This catalog covers:

'99~'00 BN175-A2/A3 Chassis

This grid covers:

Pictorial Index

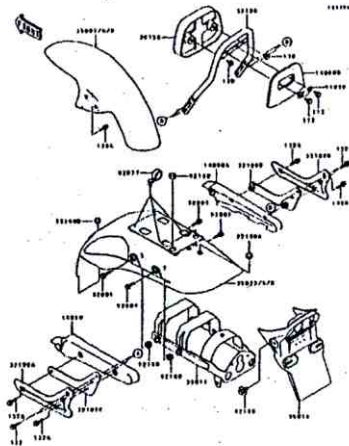

D-10 Fenders(BN175-A3)

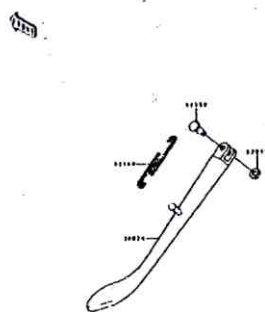

D-11 Stand(s)

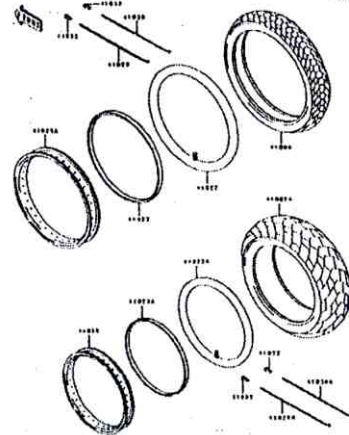

D-12 Tires

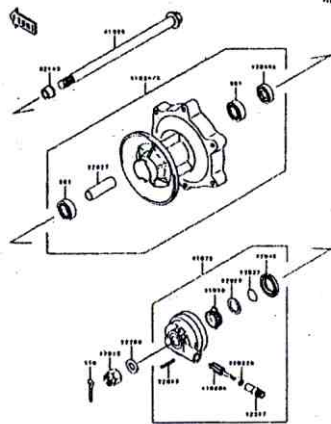

D-13 Front Hub

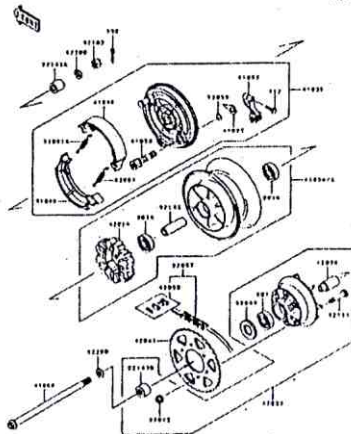

D-14 Rear Hub

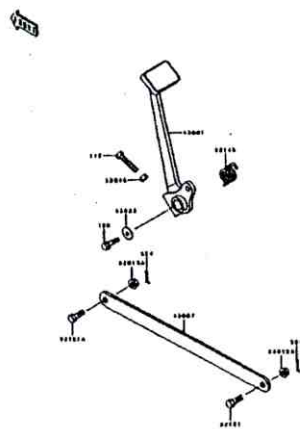

E-3 Brake Pedal

This catalog covers:

'99~'00 BN175-A2/A3 Chassis

This grid covers:

Pictorial Index

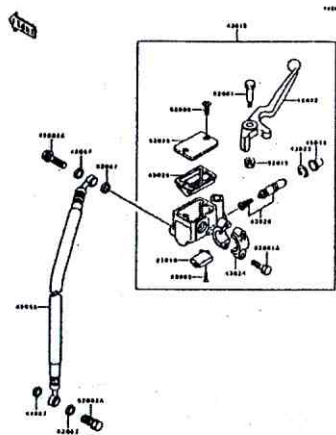

E-4 Front Master Cylinder

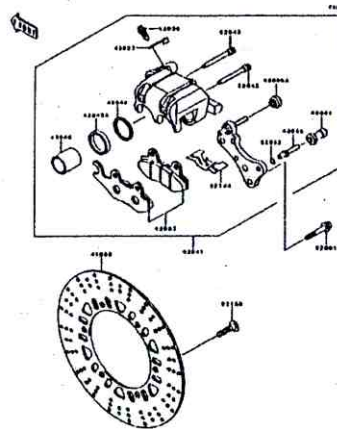

E-5 Front Brake

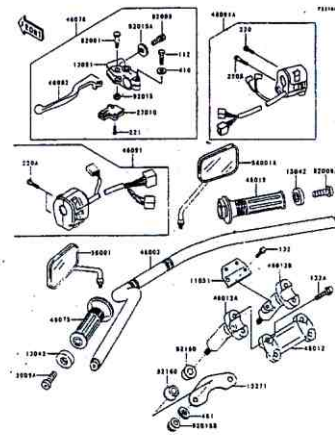

E-7 Handlebar(BN175-A3)

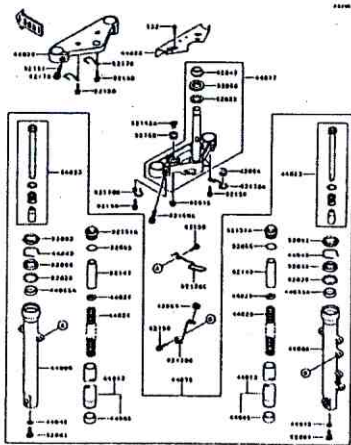

E-8 Front Fork

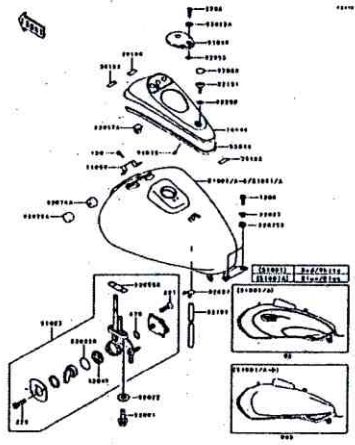

E-9 Fuel Tank

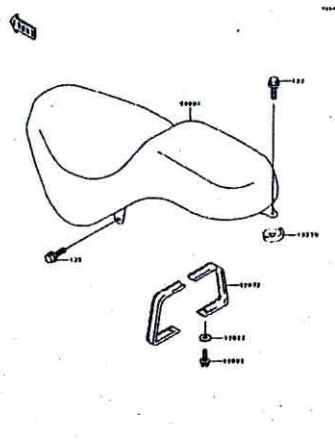

E-10 Seat

This catalog covers:
'99~'00 BN175-A2/A3 Chassis

This grid covers:
Pictorial Index

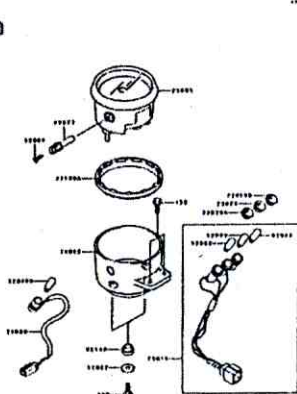

E-11 Meter(s)

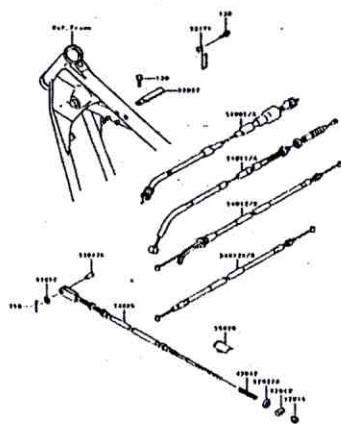

E-12 Cables

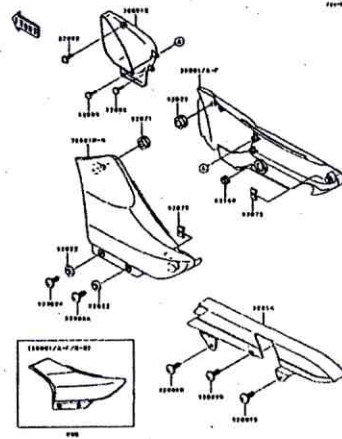

E-13 Side Covers/Chain Cover

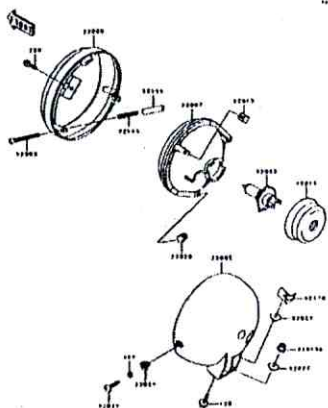

E-14 Headlight(s)

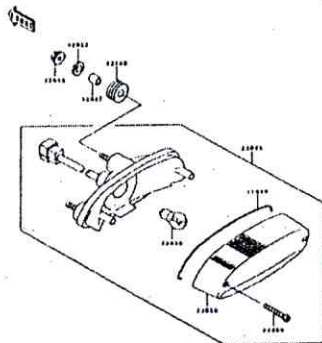

F-3 Taillight(s)

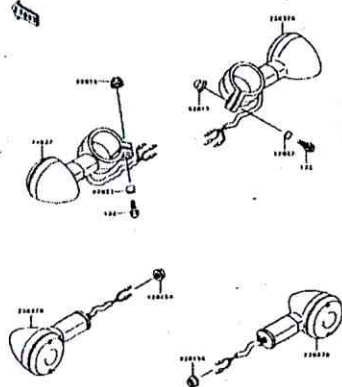

F-4 Turn Signals

This catalog covers:

'99~'00 BN175-A2/A3 Chassis

This grid covers:

Pictorial Index

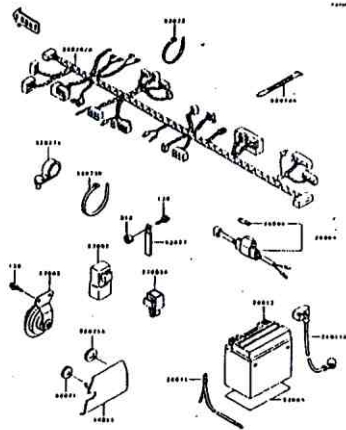

F-5 Chassis Electrical Equipment

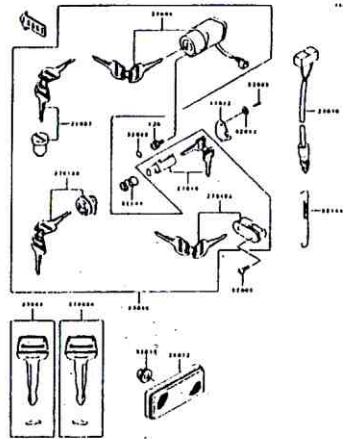

F-6 Ignition Switch

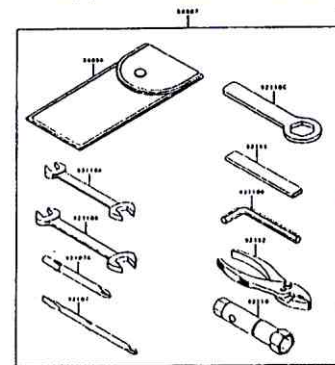

F-7 Owner's Tools

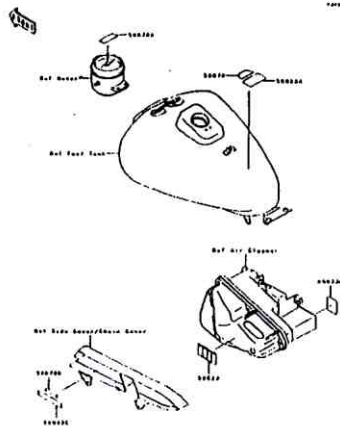

F-8 Labels

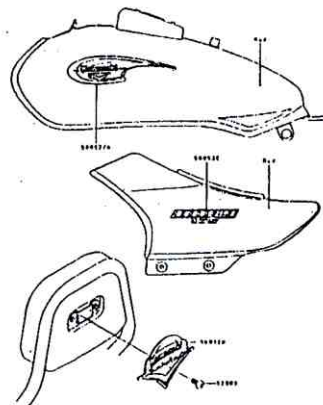

F-13/F-14 Decals(Red-Violet)

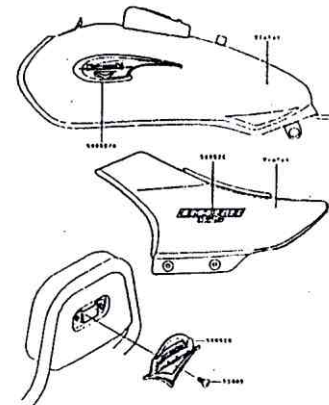

G-3/G-4 Decals(Boulogne-Black)

This catalog covers:

'99~'00 BN175-A2/A3 Engine

GRID NO.

B-3

This grid covers:

Cylinder Head

E1111

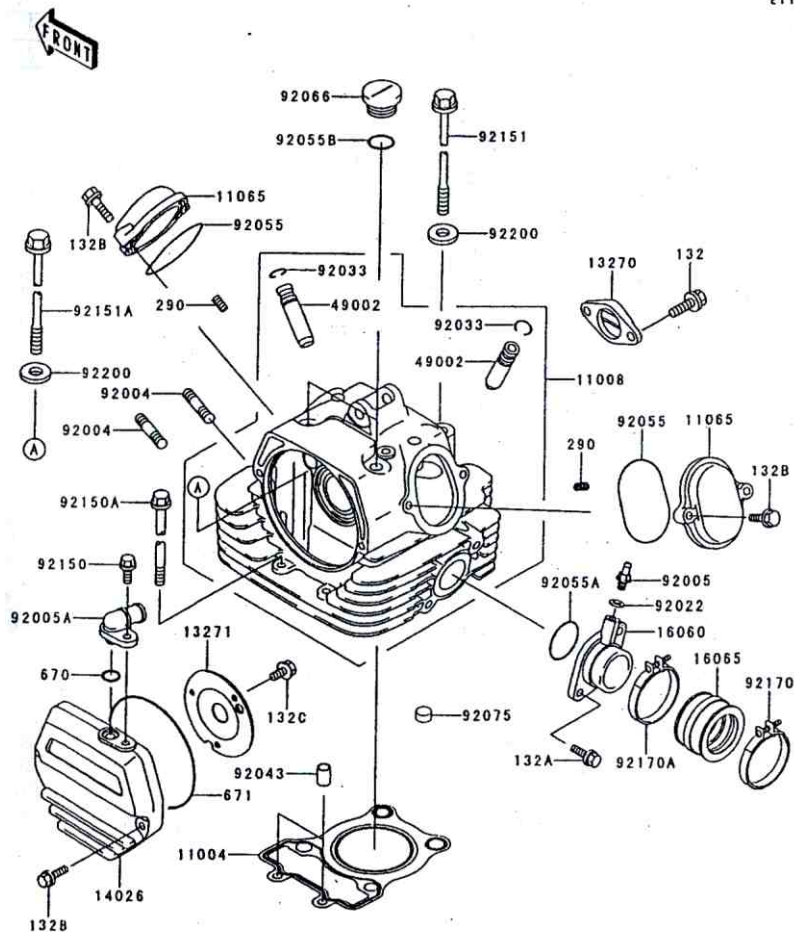

Ref. No.	Part No.	Description	Spec Code	Quantity-BN175			
				'99	'00		
				A2	A3		
11004	11004-1330	GASKET-HEAD	1	1			
11008	11008-1341	HEAD-COMP-CYLINDER	1	1			
11065	11065-1071	CAP,ROCKER CASE	2	2			
13270	13270-1910	PLATE	1	1			
13271	13271-1109	PLATE,BREATHER	1	1			
14026	14026-1256	COVER-CHAIN,CAM SPROCKET	1	1			
16060	16060-1081	PIPE-INTAKE	1	1			
16065	16065-1356	HOLDER-CARBURETOR	1	1			
49002	49002-1138	GUIDE-VALVE	AR	AR			
92004	92004-1121	STUD,8X30	2	2			
92005	92005-1337	FITTING	1	1			
92005A	92005-1342	FITTING,BREATHER	1	1			
92022	92022-077	WASHER,6.1X12X1	1	1			
92033	92033-1247	RING-SNAP	2	2			
92043	92043-4009	PIN,10.1X12X14	2	2			
92055	92055-112	RING-O,53.5X2.6	2	2			
92055A	92055-1256	RING-O,32MM	1	1			
92055B	92055-1325	RING-O,18.8X2.4	2	2			
92066	92066-1478	PLUG	2	2			
92075	92075-1089	DAMPER	30	30			
92150	92150-1394	BOLT,6X16	1	1			
92150A	92150-1986	BOLT,6X110	2	2			
92151	92151-1092	BOLT,9X228.5	2	2			
92151A	92151-1268	BOLT,9X188	2	2			
92170	92170-1387	CLAMP	1	1			
92170A	92170-1527	CLAMP,43MM	1	1			
92200	92200-1037	WASHER,9.5X18X1.2	4	4			
132	132V0614	BOLT-FLANGED-SMALL	2	2			
132A	132V0618	BOLT-FLANGED-SMALL	2	2			
132B	132V0625	BOLT-FLANGED-SMALL	6	6			
132C	132Y0612	BOLT-FLANGED-SMALL	3	3			
290	290Q0606	SCREW-SET-SOCKET,6X6	2	2			
670	670B1510	O RING,10MM	1	1			
671	671B2595	O RING,95MM	1	1			

This catalog covers:

'99~'00 BN175-A2/A3 Engine

GRID NO.

B-4

This grid covers:

Cylinder/Piston(s)

E1120

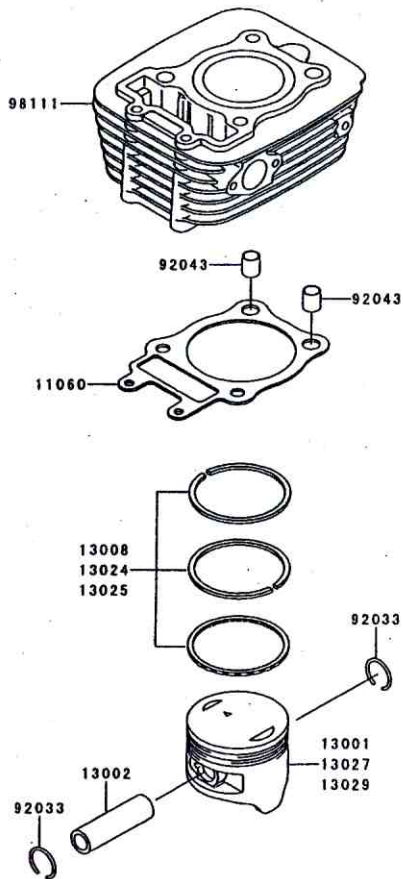

Ref. No.	Part No.	Description	Spec Code	Quantity-BN175			
				'99	'00		
				A2	A3		
11060	11060-1762	GASKET,CYLINDER BASE	1	1			
13001	13001-1506	PISTON-ENGINE,STD	1	1			
13002	13002-1003	PIN-PISTON	1	1			
13008	13008-1183	RING-SET-PISTON,STD	1	1			
13024	13024-1114	RING-SET-PISTON LL,O/S 1.00	AR	AR			
13025	13025-1142	RING-SET-PISTON L,O/S 0.50	AR	AR			
13027	13027-1197	PISTON-ENGINE LL,O/S 1.00	AR	AR			
13029	13029-1253	PISTON-ENGINE L,O/S 0.50	AR	AR			
92033	92033-1161	RING-SNAP,PISTON PIN	2	2			
92043	92043-4009	PIN,10.1X12X14	2	2			
98111	98111-1073	CYLINDER-COMP-ENGINE	1	1			

This catalog covers:

'99~'00 BN175-A2/A3 Engine

GRID NO.

B-5

This grid covers:

Air Cleaner

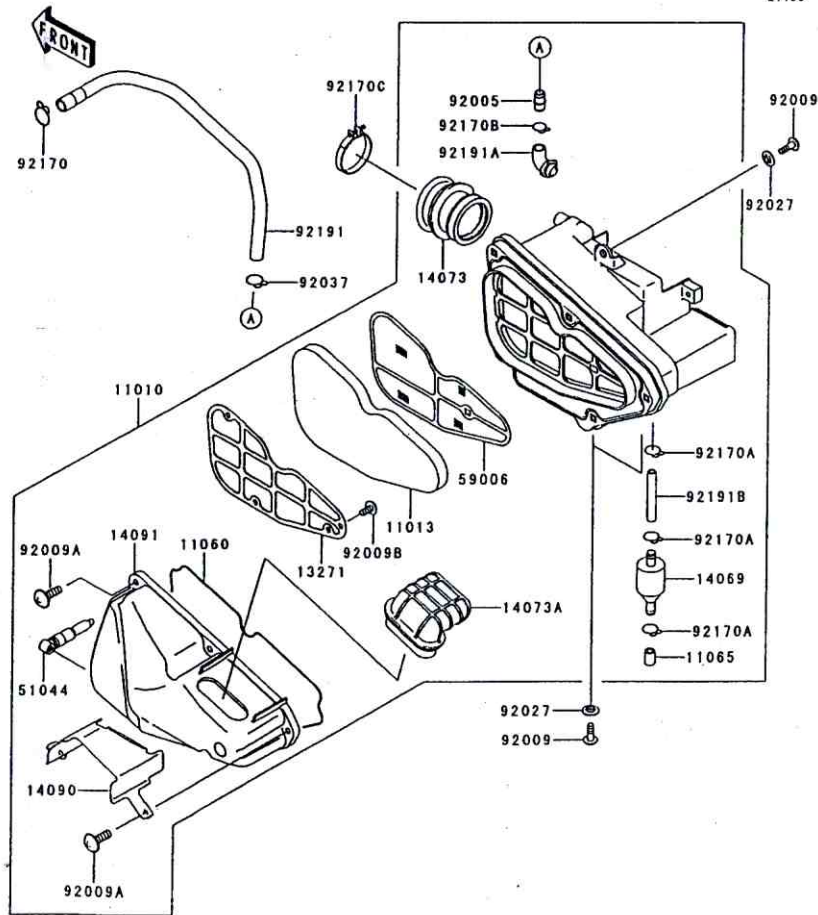

Ref. No.	Part No.	Description	Spec Code	Quantity-BN175			
				'99	'00		
				A2	A3		
11010	11010-1678	FILTER-ASSY-AIR		1	1		
11013	11013-1268	ELEMENT-AIR FILTER		1	1		
11060	11060-1808	GASKET,AIR FILTER		1	1		
11065	11065-1088	CAP,BREATHER		1	1		
13271	13271-1103	PLATE,ELEMENT		1	1		
14069	14069-1064	BREATHER		1	1		
14073	14073-1725	DUCT,CARBURETOR		1	1		
14073A	14073-1734	DUCT,INTAKE		1	1		
14090	14090-1977	COVER,INTAKE DUCT		1	1		
14091	14091-1113	COVER,AIR FILTER ELEMENT		1	1		
51044	51044-1196	TUBE-ASSY,DRAIN		1	1		
59006	59006-1057	ARRESTER-FLAME		1	1		
92005	92005-1247	FITTING		1	1		
92009	92009-1621	SCREW,6X16		3	3		
92009A	92009-1830	SCREW,6X18		5	5		
92009B	92009-1831	SCREW,TAPPING 5X10		3	3		
92027	92027-1757	COLLAR		3	3		
92037	92037-192	CLAMP,BREATHER TUBE		1	1		
92170	92170-1017	CLAMP		1	1		
92170A	92170-1796	CLAMP		3	3		
92170B	92170-1845	CLAMP		1	1		
92170C	92170-1864	CLAMP		1	1		
92191	92191-1162	TUBE,BREATHER		1	1		
92191A	92191-1208	TUBE,BREATHER		1	1		
92191B	92191-1241	TUBE,7X12X45		1	1		

This catalog covers:

'99~'00 BN175-A2/A3 Engine

GRID NO.

B-6

This grid covers:

Muffler(s)



E1140

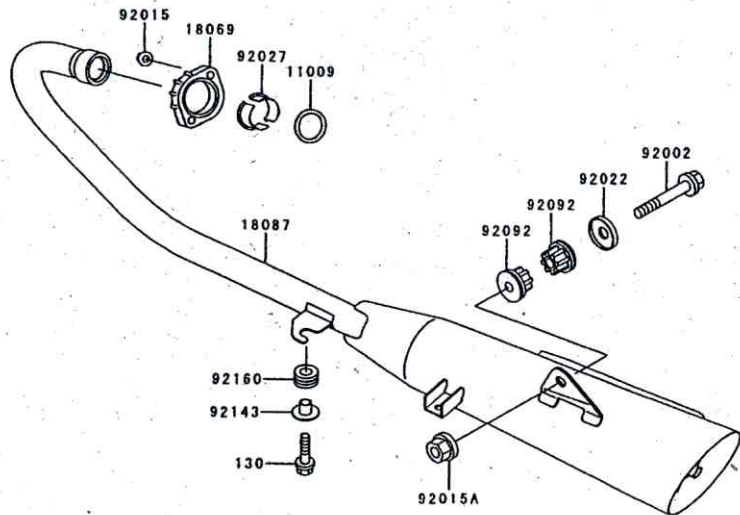

Ref. No.	Part No.	Description	Spec Code	Quantity-BN175			
				'99	'00		
				A2	A3		
11009	11009-1866	GASKET,EXHAUST PIPE HOLDER	1	1			
18069	18069-1014	HOLDER-EXHAUST PIPE	1	1			
18087	18087-1078	MUFFLER	1	1			
92002	92002-1826	BOLT,10X55	1	1			
92015	92015-1371	NUT,CAP,8MM	2	2			
92015A	92015-1387	NUT,FLANGED,10MM	1	1			
92022	92022-289	WASHER	1	1			
92027	92027-1142	COLLAR,L=14.5	2	2			
92092	92092-1013	BUSHING-RUBBER,MUFFLER	2	2			
92143	92143-1353	COLLAR	1	1			
92160	92160-1895	DAMPER	1	1			
130	130J0622	BOLT-FLANGED,6X22,BLACK	1	1			

This catalog covers:

'99~'00 BN175-A2/A3 Engine

GRID NO. This grid covers:

B-7 Valve(s)

E1210

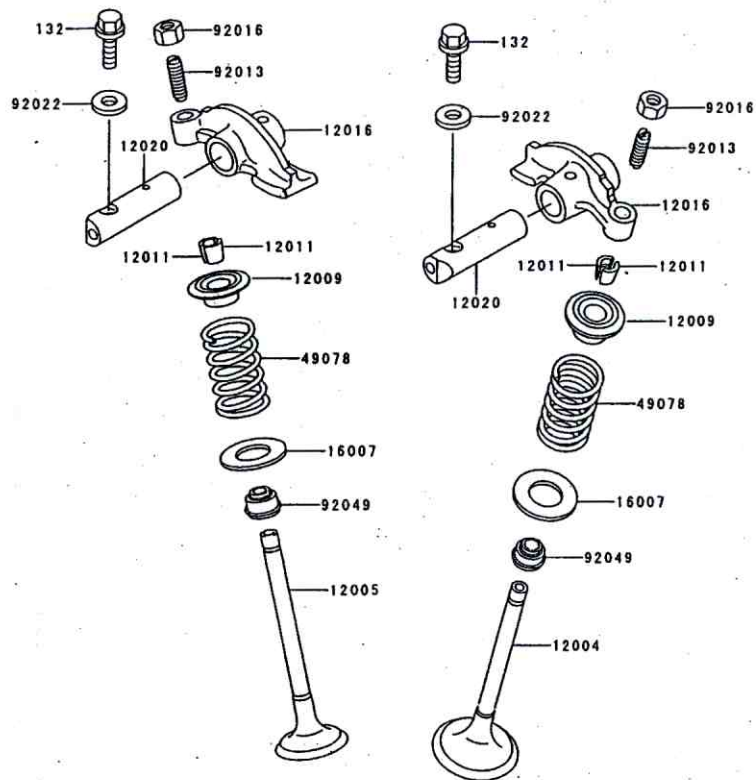

Ref. No.	Part No.	Description	Spec Code	Quantity-BN175			
				'99	'00		
				A2	A3		
12004	12004-1144	VALVE-INTAKE	1	1			
12005	12005-1294	VALVE-EXHAUST	1	1			
12009	12009-1074	RETAINER-VALVE SPRING,INTAKE	2	2			
12011	12011-1053	COLLET	4	4			
12016	12016-1115	ARM-ROCKER	2	2			
12020	12020-1080	SHAFT-ROCKER	2	2			
16007	16007-1159	SEAT-SPRING	2	2			
49078	49078-1189	SPRING-ENGINE VALVE	2	2			
92013	92013-009	SCREW,6MM	2	2			
92016	92016-061	NUT,6MM	2	2			
92022	92022-077	WASHER,6.1X12X1	2	2			
92049	92049-1349	SEAL-OIL	2	2			
132	132V0625	BOLT-FLANGED-SMALL	2	2			

This catalog covers:

'99~'00 BN175-A2/A3 Engine

GRID NO.

B-8

This grid covers:

Camshaft(s)/Tensioner

E1230

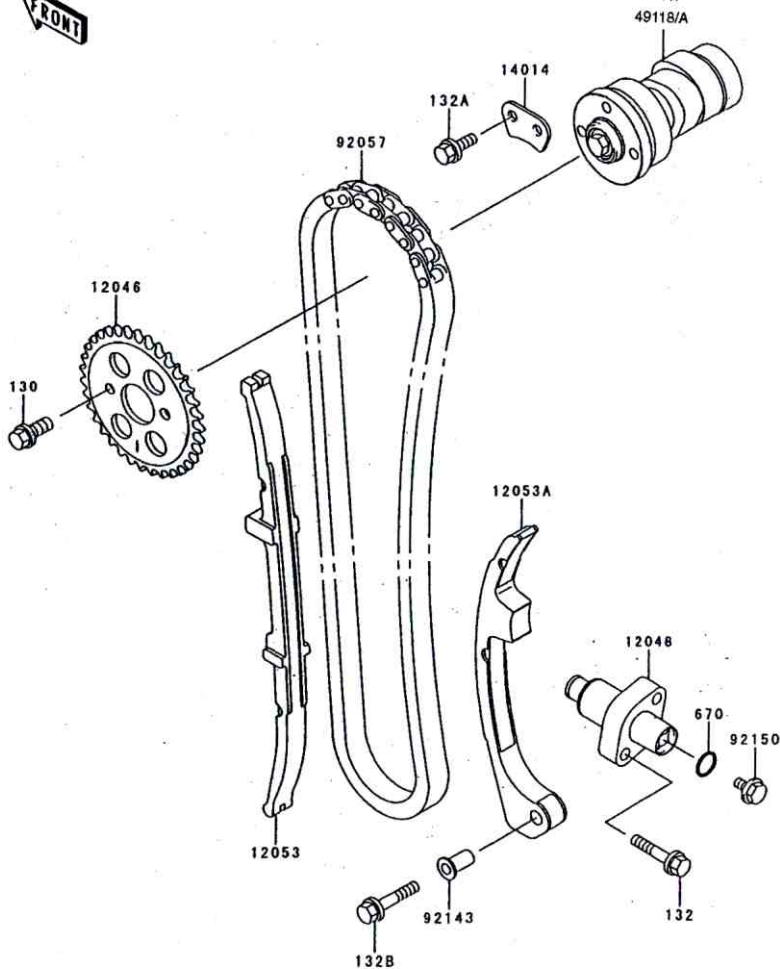

Ref. No.	Part No.	Description	Spec Code	Quantity-BN175			
				'99	'00		
				A2	A3		
12046	12046-1192	SPROCKET		1	1		
12048	12048-1169	TENSIONER-ASSY		1	1		
12053	12053-1383	GUIDE-CHAIN,FR		1	1		
12053A	12053-1421	GUIDE-CHAIN,RR		1	1		
14014	14014-1095	PLATE-POSITION		1	1		
49118	49118-1164	CAMSHAFT-COMP		1			
49118A	49118-1199	CAMSHAFT-COMP			1		
92057	92057-1457	CHAIN,CAM,92RH2010-102M		1	1		
92143	92143-1857	COLLAR		1	1		
92150	92150-1381	BOLT-TENSIONER		1	1		
130	130S0612	BOLT-FLANGED				2	2
132	132V0625	BOLT-FLANGED-SMALL				2	2
132A	132Y0614	BOLT-FLANGED-SMALL				2	2
132B	132Y0630	BOLT-FLANGED-SMALL				1	1
670	670D2010	O RING				1	1

This catalog covers:

'99~'00 BN175-A2/A3 Engine

GRID NO.

B-9

This grid covers:

Crankshaft

E1321

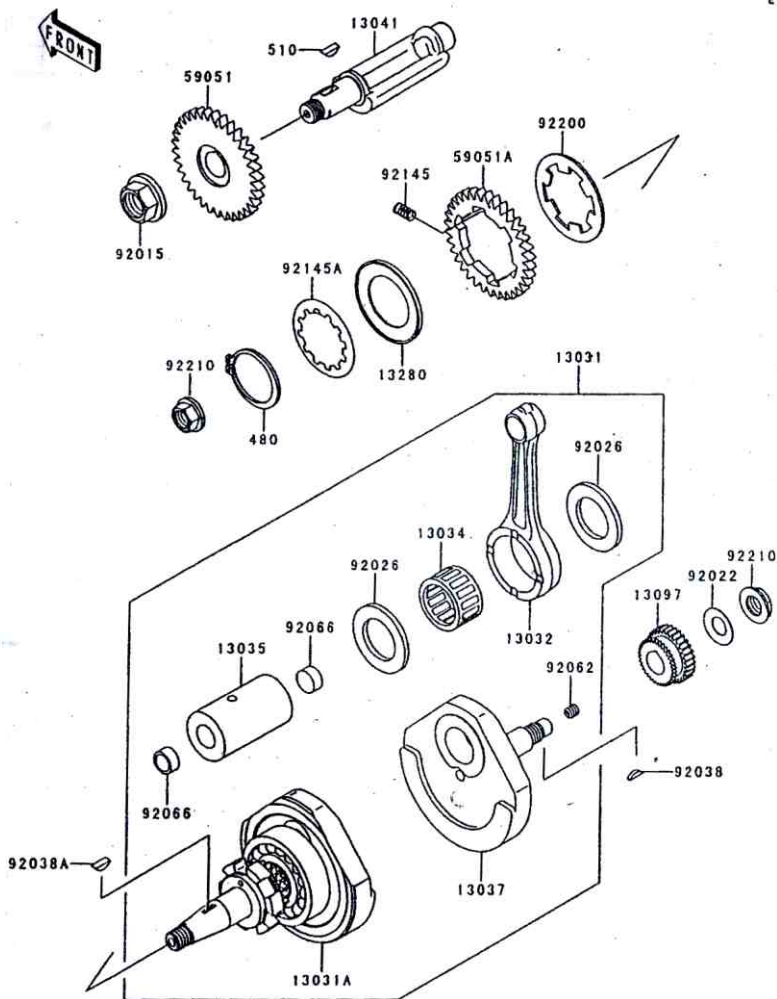

Ref. No.	Part No.	Description	Spec Code	Quantity-BN175			
				'99	'00		
				A2	A3		
13031	13031-1435	CRANKSHAFT-COMP	1	1			
13031A	13031-1461	CRANKSHAFT-COMP,LH	1	1			
13032	13032-1268	ROD-CONNECTING	1	1			
13034	13034-1105	BEARING-BIG END,B4	1	1			
13035	13035-1084	PIN-CRANK	1	1			
13037	13037-1578	CRANKSHAFT,RH	1	1			
13041	13041-1129	BALANCER	1	1			
13097	13097-1378	GEAR-PRIMARY SPUR.	1	1			
13280	13280-1121	HOLDER,BALANCER	1	1			
59051	59051-1324	GEAR-SPUR,BALANCER	1	1			
59051A	59051-1325	GEAR-SPUR,BALANCER	1	1			
92015	92015-1465	NUT,16MM	1	1			
92022	92022-1232	WASHER,SPRING,14M/M	1	1			
92026	92026-1235	SPACER	2	2			
92038	92038-001	KEY,WOODRUFF	1	1			
92038A	92038-3703	KEY,WOODRUFF	1	1			
92062	92062-1053	NOZZLE	1	1			
92066	92066-1249	PLUG	2	2			
92145	92145-1195	SPRING	6	6			
92145A	92145-1196	SPRING	1	1			
92200	92200-1314	WASHER	1	1			
92210	92210-1163	NUT,14MM	2	2			
480	480J4000	CIRCLIP	1	1			
510	510A5100	KEY-WOODRUFF	1	1			

This catalog covers:

'99~'00 BN175-A2/A3 Engine

GRID NO.

This grid covers:

B-10

Clutch

E1350

FRONT

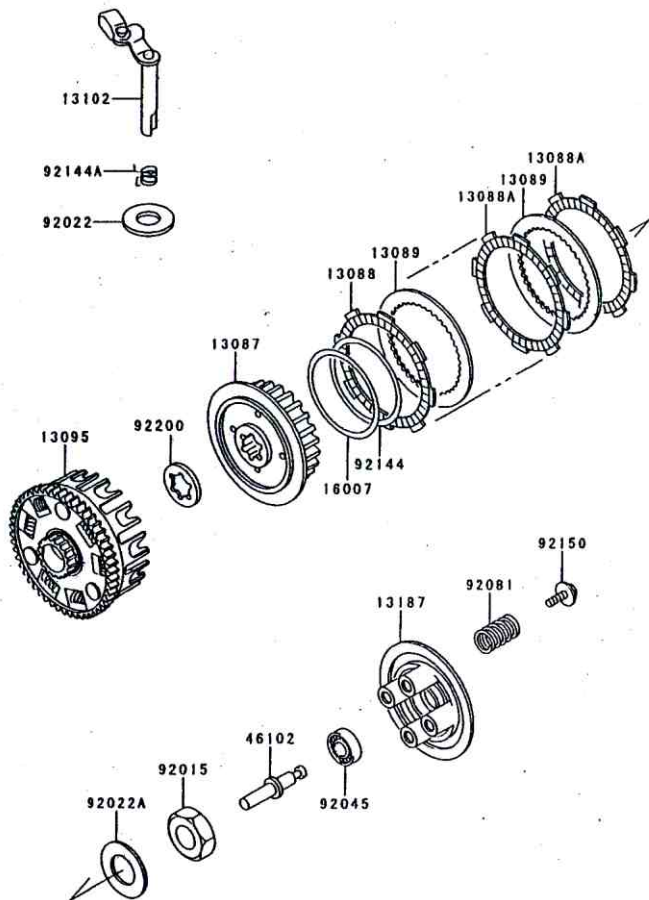

Ref. No.	Part No.	Description	Spec Code	Quantity-BN175			
				'99	'00	A2	A3
13087	13087-1169	HUB-CLUTCH		1	1		
13088	13088-1085	PLATE-FRICTION		1	1		
13088A	13088-1098	PLATE-FRICTION		4	4		
13089	13089-1076	PLATE-CLUTCH		4	4		
13095	13095-1388	HOUSING-COMP-CLUTCH		1	1		
13102	13102-1139	RELEASE-COMP-CLUTCH		1	1		
13187	13187-1072	PLATE-CLUTCH OPERATING		1	1		
16007	16007-1162	SEAT-SPRING		1	1		
46102	46102-1402	ROD		1	1		
92015	92015-072	NUT,LOCK,16MM		1	1		
92022	92022-072	WASHER,12.5X21X1.2		1	1		
92022A	92022-1356	WASHER,16.3X29X1.75		1	1		
92045	92045-1235	BEARING-BALL,6001C3ML01		1	1		
92081	92081-1492	SPRING,CLUTCH		4	4		
92144	92144-1522	SPRING		1	1		
92144A	92144-1995	SPRING,RELEASE SHAFT		1	1		
92150	92150-1715	BOLT		4	4		
92200	92200-1440	WASHER		1	1		

This catalog covers:

'99~'00 BN175-A2/A3 Engine

GRID NO.

This grid covers:

B-11

Transmission

E1361

Ref. No.	Part No.	Description	Spec Code	Quantity-BN175			
				'99	'00		
				A2	A3		
13127	13127-1263	SHAFT-TRANSMISSION INPUT,10T	1	1			
13128	13128-1225	SHAFT-TRANSMISSION OUTPUT	1	1			
13129	13129-1555	GEAR,INPUT 2ND,17T	1	1			
13139	13139-1080	SHIFTER	1	1			
13144	13144-1144	SPROCKET-OUTPUT,16T	1	1			
13260	13260-1704	GEAR,OUTPUT 2ND,29T	1	1			
13260A	13260-1772	GEAR,INPUT 3RD&4TH,20T&22T	1	1			
13260B	13260-1773	GEAR,INPUT TOP,21T	1	1			
13260C	13260-1774	GEAR,OUTPUT LOW,27T	1	1			
13260D	13260-1775	GEAR,OUTPUT 3RD,26T	1	1			
13260E	13260-1776	GEAR,OUTPUT 4TH,24T	1	1			
13260F	13260-1777	GEAR,OUTPUT TOP,20T	1	1			
13271	13271-1052	PLATE,SPROCKET	1	1			
92022	92022-1033	WASHER,TOOTHED,20.3X24X0.5	2	2			
92022A	92022-252	WASHER,20.5X25.5X0.5	1	1			
92033	92033-1260	RING-SNAP	1	1			
92033A	92033-1313	RING-SNAP	6	6			
92055	92055-022	RING-O,17.5X1.5	1	1			
92143	92143-1869	COLLAR,SPROCKET	1	1			
120	120Q0608	BOLT-SOCKET	2	2			

FRONT

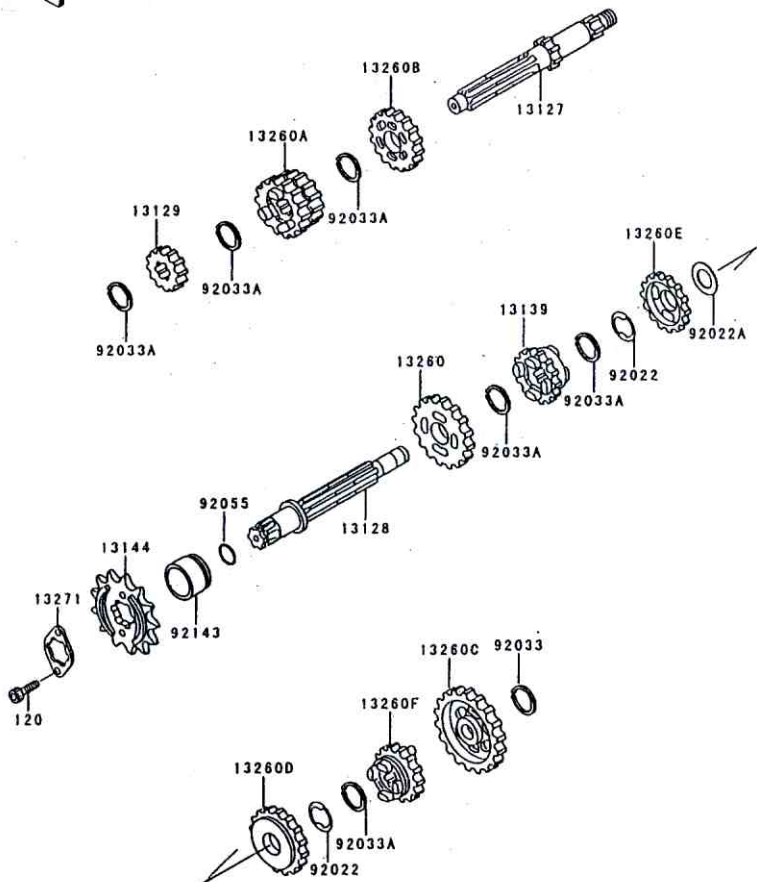

This catalog covers:

'99~'00 BN175-A2/A3 Engine

GRID NO.

This grid covers:

B-12

Gear Change Drum/Shift Fork(s)

E1362

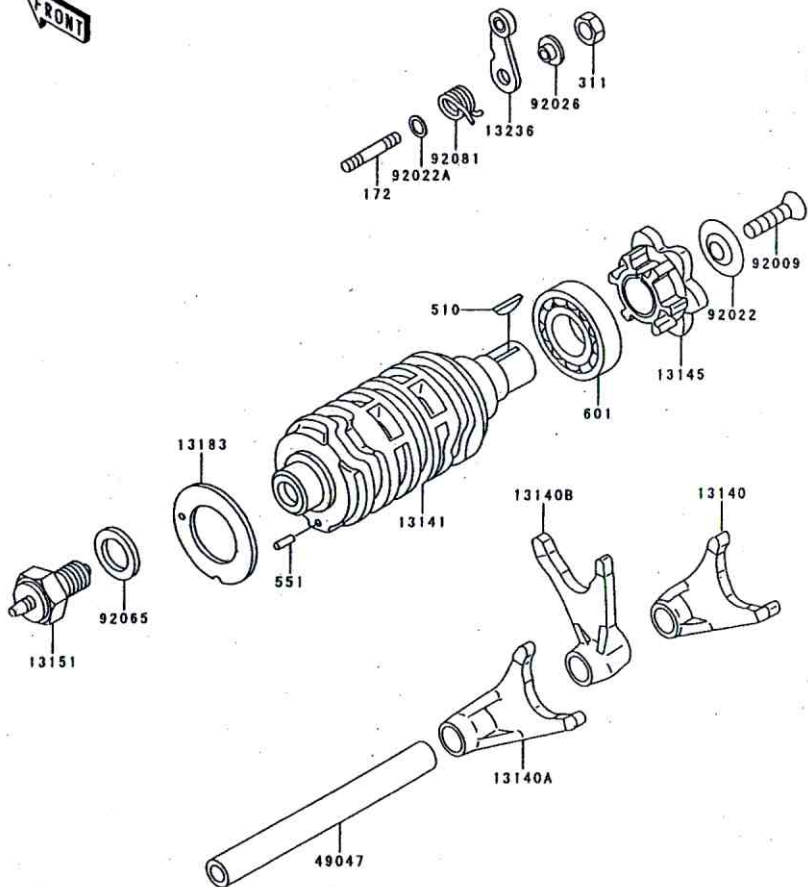

Ref. No.	Part No.	Description	Spec Code	Quantity-BN175			
				'99	'00		
13140	13140-1278	FORK-SHIFT,LOW/3RD		1	1		
13140A	13140-1279	FORK-SHIFT,2ND/4TH		1	1		
13140B	13140-1280	FORK-SHIFT,5TH/TOP		1	1		
13141	13141-1210	DRUM-CHANGE		1	1		
13145	13145-1084	CAM-CHANGE DRUM		1	1		
13151	13151-1080	SWITCH-COMP,NEUTRAL		1	1		
13183	13183-1066	PLATE,CHANGE		1	1		
13236	13236-1192	LEVER-COMP,DRUM POSITION		1	1		
49047	49047-1068	ROD-SHIFT		1	1		
92009	92009-1360	SCREW,6X16		1	1		
92022	92022-1792	WASHER		1	1		
92022A	92022-1827	WASHER,6X12.8X1.2		1	1		
92026	92026-1217	SPACER		1	1		
92065	92065-058	GASKET,10.5X16X1,DRAIN PLUG		1	1		
92081	92081-1993	SPRING,POSITION LEVER		1	1		
172	172G0612	BOLT-STUD,6X12		1	1		
311	311G0600	NUT-HEX,6MM		1	1		
510	510A3200	KEY-WOODRUFF		1	1		
551	551A0306	PIN-DOWEL,3X6		1	1		
601	601B6003	BEARING-BALL		1	1		

This catalog covers:

'99~'00 BN175-A2/A3 Engine

GRID NO.

B-13

This grid covers:

Gear Change Mechanism

E1370

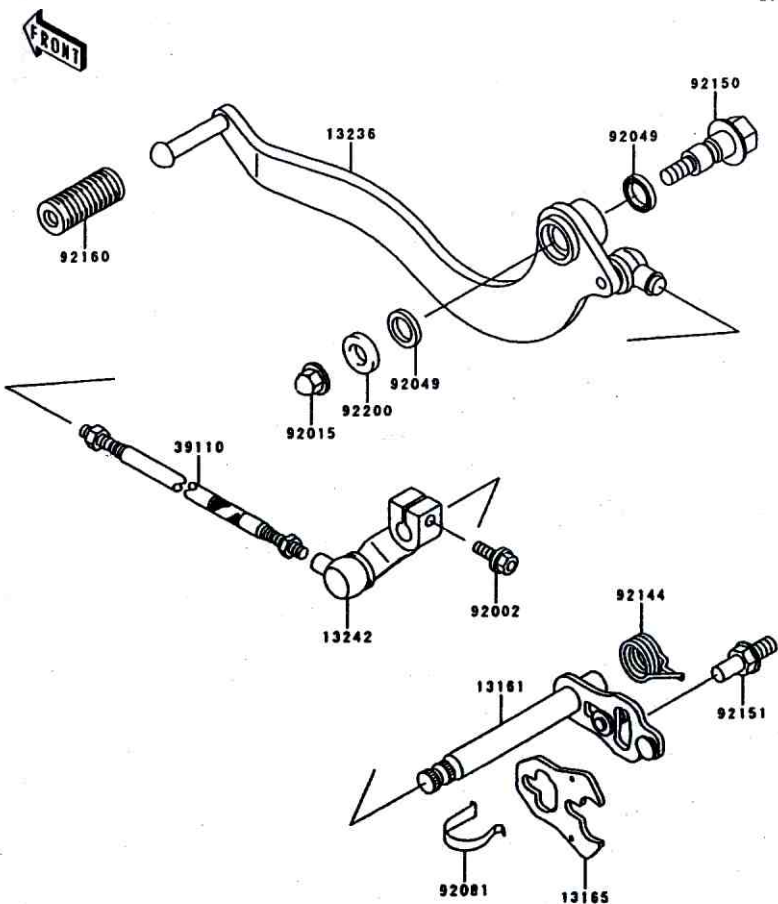

Ref. No.	Part No.	Description	Spec Code	Quantity-BN175			
				'99	'00		
				A2	A3		
13161	13161-1234	LEVER-COMP-CHANGE SHAFT	1	1			
13165	13165-1154	PAWL,CHANGE SHAFT	1	1			
13236	13236-1334	LEVER-COMP,CHANGE PEDAL	1	1			
13242	13242-1290	LEVER-ASSY-CHANGE	1	1			
39110	39110-1124	ROD-ASSY-TIE	1	1			
92002	92002-1237	BOLT,6x20	1	1			
92015	92015-1370	NUT,CAP,8MM	1	1			
92049	92049-1398	SEAL-OIL,VB13193	2	2			
92081	92081-1829	SPRING,CHANGE LEVER	1	1			
92144	92144-1074	SPRING,CHANGE PEDAL RETURN	1	1			
92150	92150-1908	BOLT-CHANGE PEDAL	1	1			
92151	92151-1362	BOLT-RETURN SPRING	1	1			
92160	92160-1637	DAMPER,CHANGE PEDAL	1	1			
92200	92200-3717	WASHER,8.5x25x1.5	1	1			

This catalog covers:

'99~'00 BN175-A2/A3 Engine

GRID NO.

This grid covers:

B-14

Crankcase

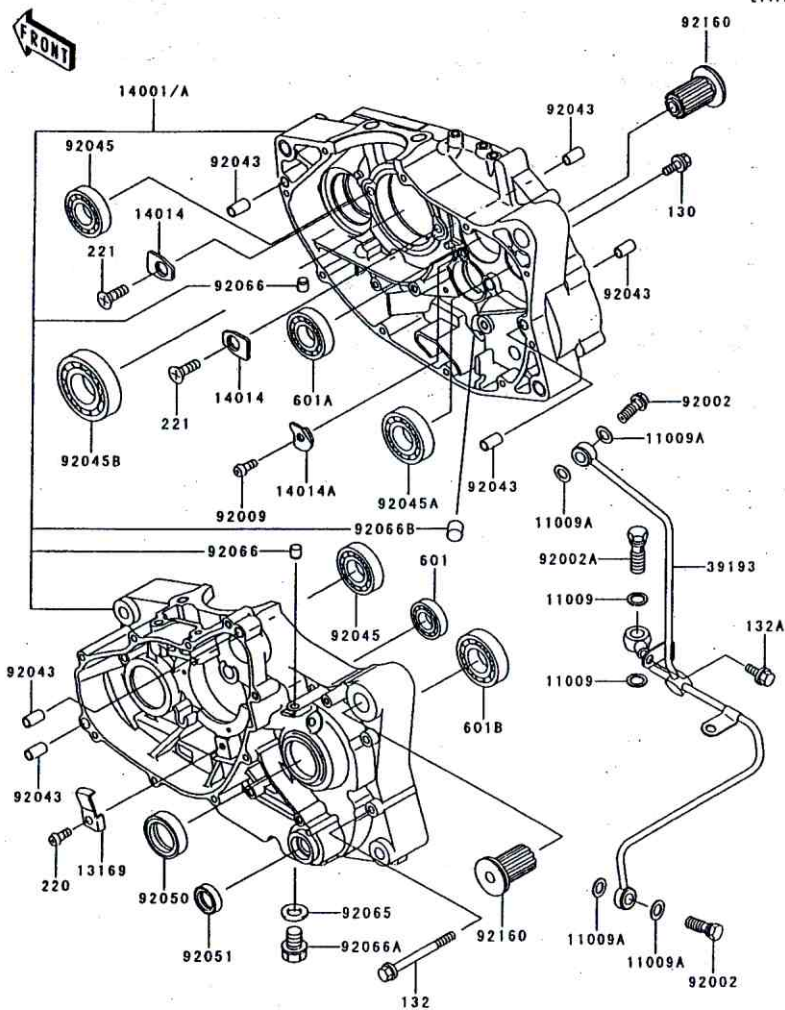

Ref. No.	Part No.	Description	Spec Code	Quantity-BN175			
				'99	'00		
				A2	A3		
11009	11009-1105	GASKET,10X14,5X1.5	2	2			
11009A	11009-1344	GASKET,OIL PIPE,8.2X14X1.0	4	4			
13169	13169-1691	PLATE	1	1			
14001	14001-1271	SET-CRANKCASE		1			
14001A	14001-1272	SET-CRANKCASE	1				
14014	14014-1057	PLATE-POSITION	2	2			
14014A	14014-1113	PLATE-POSITION,DRUM	1	1			
39193	39193-1025	PIPE-OIL	1	1			
92002	92002-1618	BOLT,BANJO,8X20	2	2			
92002A	92002-1975	BOLT,OIL,L=23	1	1			
92009	92009-1266	SCREW	1	1			
92043	92043-1263	PIN,6.2X8X14	6	6			
92045	92045-1041	BEARING-BALL,TMB204 JR	2	2			
92045A	92045-1169	BEARING-BALL,6202X19	1	1			
92045B	92045-1367	BEARING-BALL,63/28	1	1			
92050	92050-013	SEAL-OIL,SC25376	1	1			
92051	92051-005	SEAL-OIL,TB13225.5	1	1			
92065	92065-097	GASKET,12X22X2,DRAIN PLUG	1	1			
92066	92066-1012	PLUG,OIL LINE,7.2X8	2	2			
92066A	92066-1174	PLUG,OIL DRAIN,12X15	1	1			
92066B	92066-1355	PLUG,10.5MM	1	1			
92160	92160-1423	DAMPER,FR	2	2			
130	130J0612	BOLT-FLANGED	1	1			
132	132V0660	BOLT-FLANGED-SMALL	11	11			
132A	132Y0612	BOLT-FLANGED-SMALL	1	1			
220	220B0614	SCREW-PAN-CROS,6X14	1	1			
221	221B0612	SCREW-CSK-CROS,6X12	2	2			
601	601A6202Z	BEARING-BALL	1	1			
601A	601A6204	BEARING-BALL,#6204	1	1			
601B	601A6304Z	BEARING-BALL	1	1			

This catalog covers:
 '99~'00 BN175-A2/A3 Engine

GRID NO. This grid covers:
C-3 Engine Cover(s)

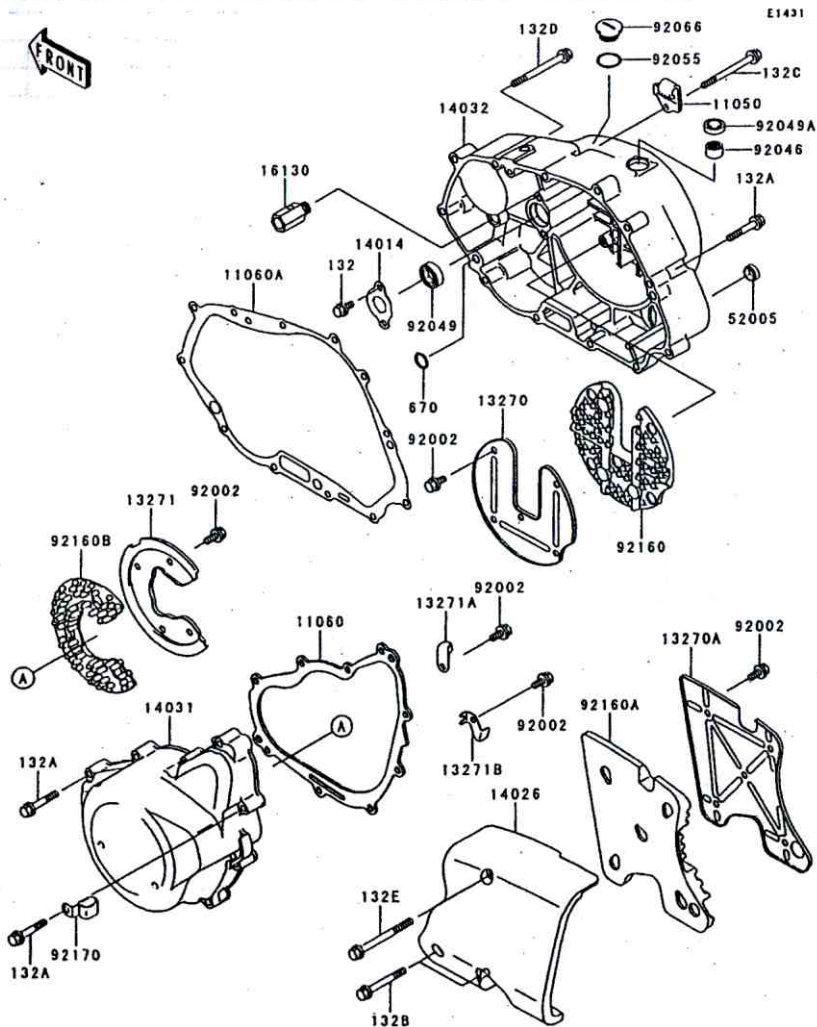

Ref. No.	Part No.	Description	Spec Code	Quantity-BN175		
				'99	'00	
				A2	A3	
11050	11050-1777	BRACKET,CABLE		1	1	
11060	11060-1751	GASKET,GENERATOR COVER		1	1	
11060A	11060-1752	GASKET,CLUTCH COVER		1	1	
13270	13270-1665	PLATE,CLUTCH COVER		1	1	
13270A	13270-1855	PLATE,CHAIN COVER		1	1	
13271	13271-1056	PLATE		1	1	
13271A	13271-1057	PLATE		1	1	
13271B	13271-1344	PLATE		1	1	
14014	14014-1129	PLATE-POSITION		1	1	
14026	14026-1265	COVER-CHAIN		1	1	
14031	14031-1368	COVER-GENERATOR		1	1	
14032	14032-1497	COVER-CLUTCH		1	1	
16130	16130-1001	VALVE-ASSY-RELIEF		1	1	
52005	52005-1009	GAUGE,OIL LEVEL		1	1	
92002	92002-1944	BOLT,6X8		16	16	
92046	92046-1010	BEARING-NEEDLE,HK1210		1	1	
92049	92049-1191	SEAL-OIL		1	1	
92049A	92049-1271	SEAL-OIL,TB12205.5		1	1	
92055	92055-1146	RING-O		1	1	
92066	92066-1482	PLUG		1	1	
92160	92160-1762	DAMPER,CLUTCH COVER		1	1	
92160A	92160-1855	DAMPER,CHAIN COVER		1	1	
92160B	92160-1923	DAMPER		1	1	
92170	92170-1833	CLAMP		1	1	
132	132G0612	BOLT-FLANGED-SMALL		2	2	
132A	132V0635	BOLT-FLANGED-SMALL		19	19	
132B	132V0650	BOLT-FLANGED-SMALL		2	2	
132C	132V0655	BOLT-FLANGED-SMALL		1	1	
132D	132V0665	BOLT-FLANGED-SMALL		1	1	
132E	132V0670	BOLT-FLANGED-SMALL		1	1	
670	670B1508	O RING,8MM		1	1	

This catalog covers:
 '99~'00 BN175-A2/A3 Engine

GRID NO. This grid covers:
C-6 Carburetor(1/2)(BN175-A3)

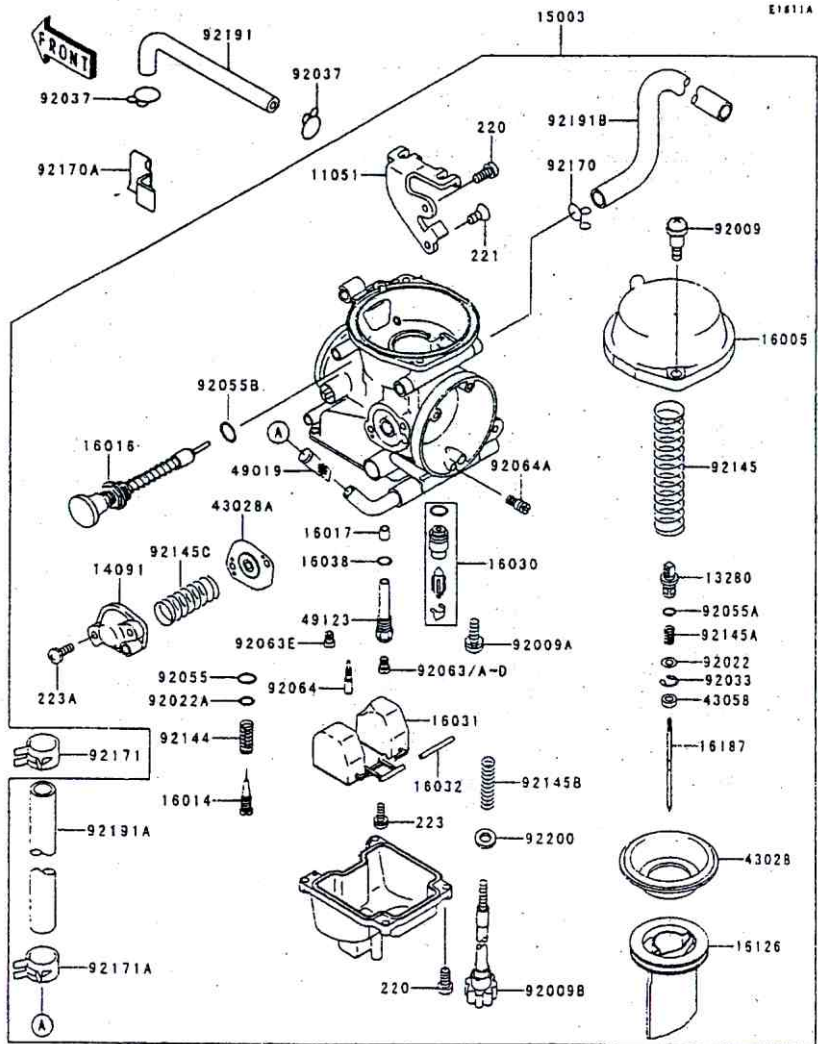

Ref. No.	Part No.	Description	Spec Code	Quantity-BN175		
				'99	'00	
			A2	A3		
11051	11051-1319	BRACKET			1	
13280	13280-1095	HOLDER			1	
14091	14091-1125	COVER			1	
15003	15003-1607	CARBURETOR-ASSY			1	
16005	16005-1086	TOP-CHAMBER			1	
16014	16014-1103	SCREW-PILOT AIR			1	
16016	16016-1110	PLUNGER			1	
16017	16017-1401	JET-NEEDLE,0-3			1	
16030	16030-1093	VALVE-FLOAT			1	
16031	16031-1101	FLOAT			1	
16032	16032-003	PIN,FLOAT			1	
16038	16038-016	GASKET,O-RING			1	
16126	16126-1371	VALVE,VACUUM			1	
16187	16187-1093	NEEDLE-JET,SD102			1	
43028	43028-1088	DIAPHRAGM			1	
43028A	43028-1089	DIAPHRAGM			1	
43058	43058-1094	RING			1	
49019	49019-1093	FILTER-FUEL			1	
49123	49123-1053	HOLDER-MAIN JET			1	
92009	92009-1850	SCREW,MIXING COVER			2	
92009A	92009-1853	SCREW,FLOAT VALVE			1	
92009B	92009-1891	SCREW			1	
92022	92022-1123	WASHER,JET NEEDLE			1	
92022A	92022-1187	WASHER,ADJUST SCREW			1	
92033	92033-1299	RING-SNAP			1	
92037	92037-1610	CLAMP			2	
92055	92055-1078	RING-O,ADJUST SCREW			1	
92055A	92055-1093	RING-O,DRAIN PLUG			1	
92055B	92055-1242	RING-O,STARTER PLUNGER			1	
92063	92063-1433	JET-MAIN,#A130			1	
	(OPTION)					
92063A	92063-1434	JET-MAIN,#A132.5			1	
	(OPTION)					
92063B	92063-1447	JET-MAIN,#A127.5			1	
92063C	92063-1449	JET-MAIN,#A122.5			1	
	(OPTION)					
92063D	92063-1471	JET-MAIN,#A125			1	
	(OPTION)					
92063E	92063-2234	JET-MAIN,#52.5			1	
92064	92064-1195	JET-PILOT,#12.5			1	

This catalog covers:

'99~'00 BN175-A2/A3 Engine

GRID NO.

C-7

This grid covers:

Carburetor(2/2)(BN175-A3)

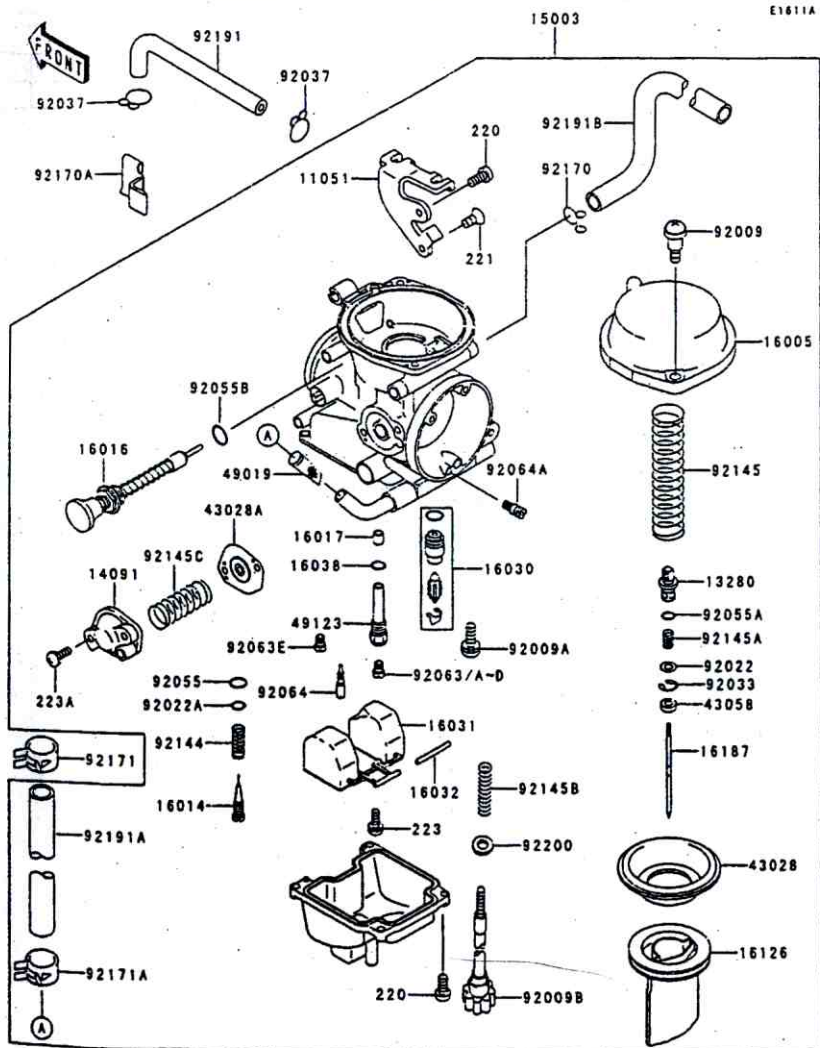

E1611A

Ref. No.	Part No.	Description	Spec Code	Quantity-BN175		
				'99	'00	
92064A	92064-1199	JET-PILOT.#72.5			1	
92144	92144-1674	SPRING,THROTTLE STOP SCREW			1	
92145	92145-1244	SPRING			1	
92145A	92145-1245	SPRING			1	
92145B	92145-1246	SPRING			1	
92145C	92145-1374	SPRING,COVER			1	
92170	92170-1818	CLAMP			1	
92170A	92170-1936	CLAMP			1	
92171	92171-1054	CLAMP			1	
92171A	92171-1302	CLAMP			1	
92191	92191-1210	TUBE.L=115			1	
92191A	92191-1349	TUBE			1	
92191B	92191-1350	TUBE			1	
92200	92200-1468	WASHER			1	
220	220D0410	SCREW-PAN-CROS			5	
221	221B0408	SCREW-CSK-CROS			1	
223	223B0408	SCREW-PAN-WS-CROS			1	
223A	223B0414	SCREW-PAN-WS-CROS			2	

This catalog covers:

'99~'00 BN175-A2/A3 Engine

GRID NO.

This grid covers:

C-8

Oil Pump

E1710

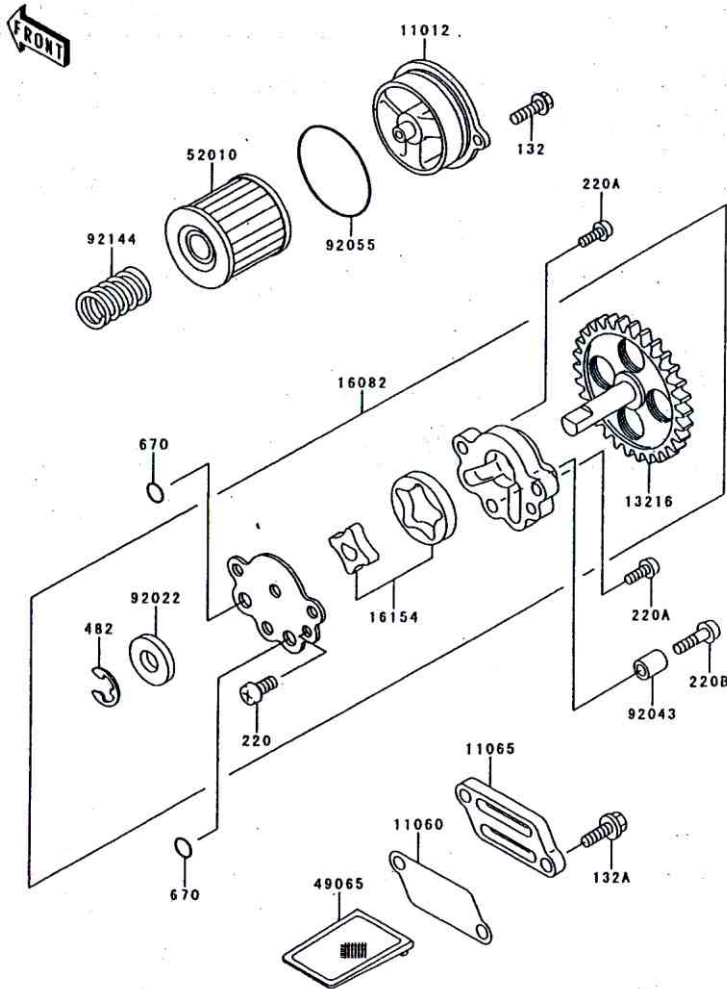

Ref. No.	Part No.	Description	Spec Code	Quantity-BN175			
				'99	'00	A2	A3
11012	11012-1971	CAP		1	1		
11060	11060-1768	GASKET,OIL FILTER		1	1		
11065	11065-1138	CAP,OIL FILTER		1	1		
13216	13216-1167	GEAR-COMP,OIL PUMP		1	1		
16082	16082-1153	PUMP-ASSY-OIL		1	1		
16154	16154-1077	ROTOR-PUMP		1	1		
49065	49065-1075	FILTER-OIL		1	1		
52010	52010-1053	ELEMENT-OIL FILTER		1	1		
92022	92022-1181	WASHER,10.2X14.5X1.0		1	1		
92043	92043-1263	PIN,6.2X8X14		1	1		
92055	92055-1577	RING-O,52.6X2.4		1	1		
92144	92144-1761	SPRING		1	1		
132	132V0616	BOLT-FLANGED-SMALL,6X16		2	2		
132A	132V0620	BOLT-FLANGED-SMALL		2	2		
220	220B0610	SCREW-PAN-CROS,6X10		1	1		
220A	220B0620	SCREW-PAN-CROS,6X20,WHITE		2	2		
220B	220B0630	SCREW-PAN-CROS,6X30		1	1		
482	482J6000	CIRCLIP-TYPE-E,6MM		1	1		
670	670B1510	O RING,10MM		2	2		

This catalog covers:

'99~'00 BN175-A2/A3 Engine

GRID NO.

C-9

This grid covers:

Generator

FRONT

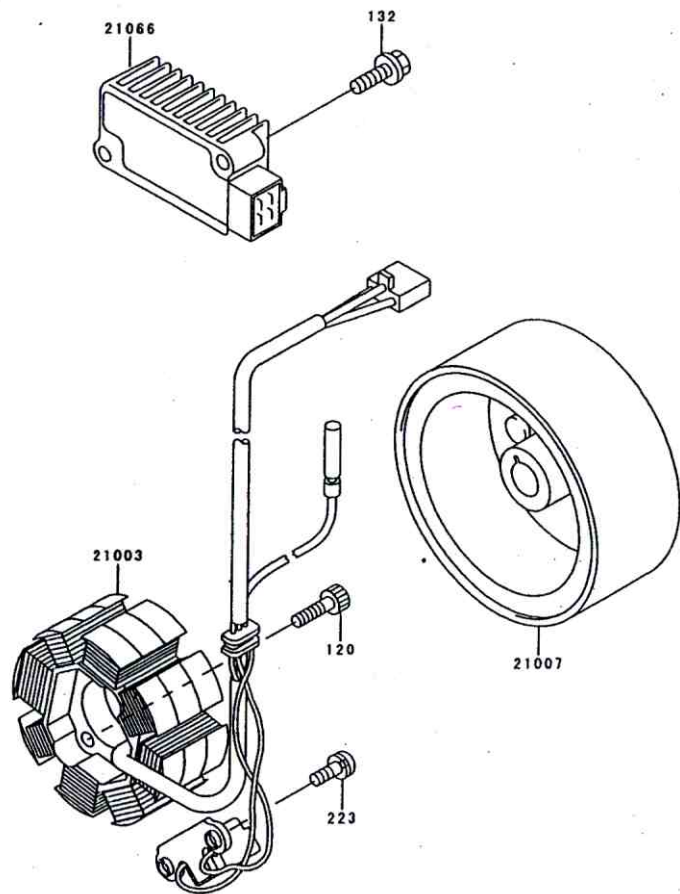

E1810

Ref. No.	Part No.	Description	Spec Code	Quantity-BN175			
				'99	'00	A2	A3
21003	21003-1342	STATOR		1	1		
21007	21007-1346	ROTOR		1	1		
21066	21066-1108	REGULATOR-VOLTAGE		1	1		
120	120P0630	BOLT-SOCKET,6X30		3	3		
132	132J0625	BOLT-FLANGED-SMALL		2	2		
223	223B0514	SCREW-PAN-WS-CROS		2	2		

This catalog covers:

'99~'00 BN175-A2/A3 Engine

GRID NO.

This grid covers:

C-10

Ignition System

FRONT

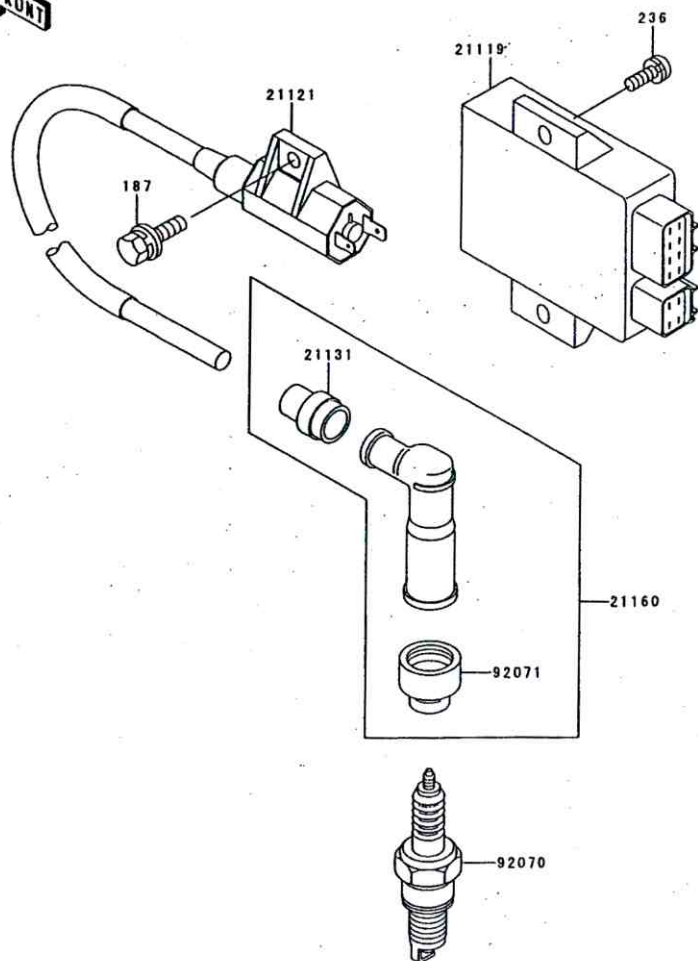

E1830

Ref. No.	Part No.	Description	Spec Code	Quantity-BN175		
				'99	'00	
				A2	A3	
21119A	21119-1560	IGNITER		1		
21121	21121-1229	COIL-IGNITION		1	1	
21131	21131-005	GROMMET,HIGH TENSION		1	1	
21160	21160-1062	CAP-ASSY-PLUG		1	1	
92070	92070-1168	PLUG-SPARK,C8E(NGK)		1	1	
92071	92071-1124	GRUMMET,PLUG CAP		1	1	
187	187B0620	BOLT-UPSET-WSP		1	1	
236	236D0616	SCREW-PAN-WSP-CROS		2	2	

This catalog covers:

'99~'00 BN175-A2/A3 Engine

GRID NO.

C-11

This grid covers:

Starter Motor

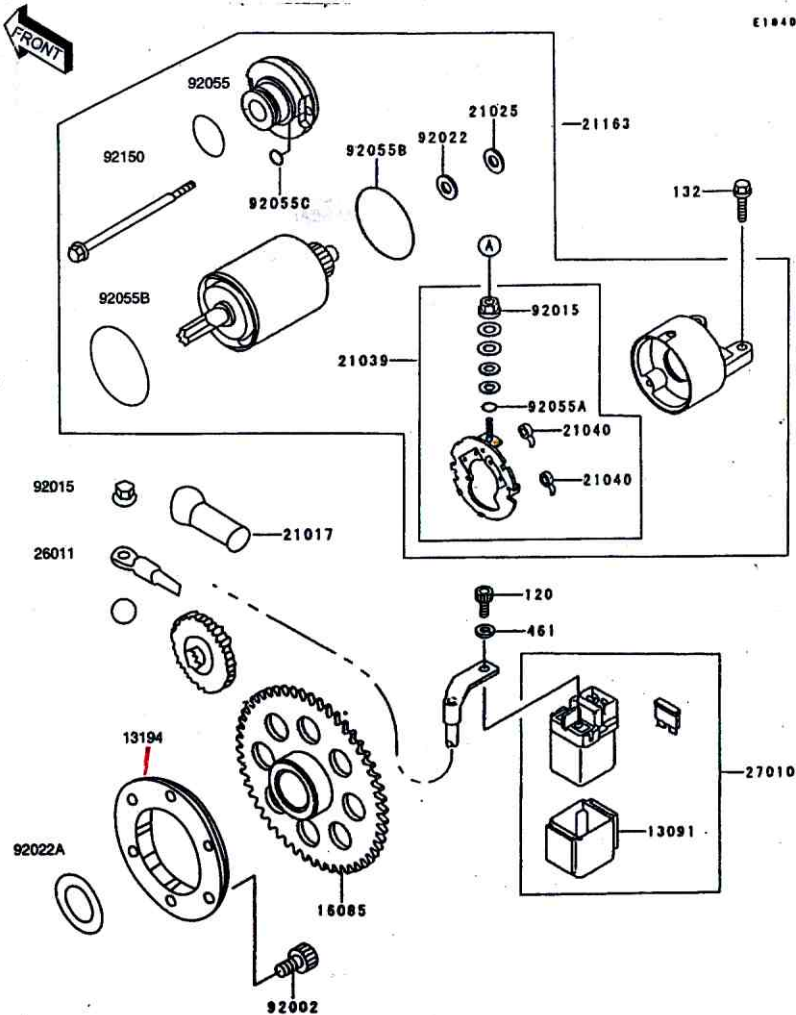

E1840

Ref. No.	Part No.	Description	Spec Code	Quantity-BN175			
				'99	'00	A2	A3
13091	13091-1884	HOLDER,MAGNETIC SWITCH		1	1		
13194	13194-1107	CLUTCH-ONEWAY		1	1		
16085	16085-1309	GEAR		1	1		
21017	21017-017	GROMMET,STARTER TERMINAL		1	1		
21025	21025-011	WASHER,9.1X18X0.2		AR	AR		
21039	21039-1066	BRUSH		1	1		
21040	21040-1057	SPRING-BRUSH		2	2		
21163	21163-1290	STARTER-ELECTRIC		1	1		
26011	26011-1682	WIRE-LEAD,STARTER		1	1		
27010	27010-1327	SWITCH,MAGNETIC		1	1		
39076	39076-1060	LIMITER,STARTER IDLE		1	1		
92002	92002-1796	BOLT,SOCKET,6X12		6	6		
92015	92015-1476	NUT,STARTER MOTOR		2	2		
92022	92022-1132	WASHER,9.1X18X0.8		1	1		
92022A	92022-212	WASHER,22.3X35X1.6		1	1		
92055	92055-1276	RING-O		1	1		
92055A	92055-1370	RING-O,4.5X2.0		1	1		
92055B	92055-1550	RING-O		2	2		
92055C	92055-1551	RING-O		2	2		
92150	92150-1969	BOLT		2	2		
120	120S0510	BOLT-SOCKET		2	2		
132	132V0625	BOLT-FLANGED-SMALL		2	2		
461	461K0500	WASHER-SPRING,5MM,BLACK		2	2		

This catalog covers:

'99~'00 BN175-A2/A3 Chassis

GRID NO.

D-3

This grid covers:

Frame

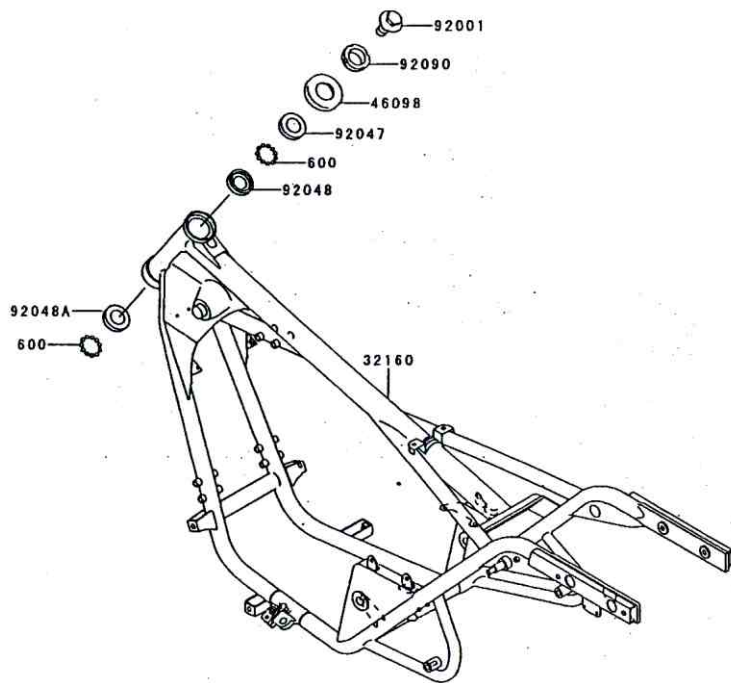

F2120

Ref. No.	Part No.	Description	Spec Code	Quantity-BN175			
				'99	'00		
32160	32160-1590	FRAME-COP		1	1		
46098	46098-016	CAP STEERINGSTEM		1	1		
92001	92001-1488	BOLT, FLANGED, 16x12		1	1		
92047	92047-011	RACE STEERING STEM BEARING		1	1		
92048	92048-006	RACE STEERING STEM BEARING		1	1		
92048A	92048-008	RACE STEERING STEM BEARING		1	1		
92090	92090-007	NUT, 30MM		1	1		
600	600A0800	BALL-STEEL, 1/4"		39	39		

This catalog covers:

'99~'00 BN175-A2/A3 Chassis

GRID NO.

D-4

This grid covers:

Frame Fittings

F2131

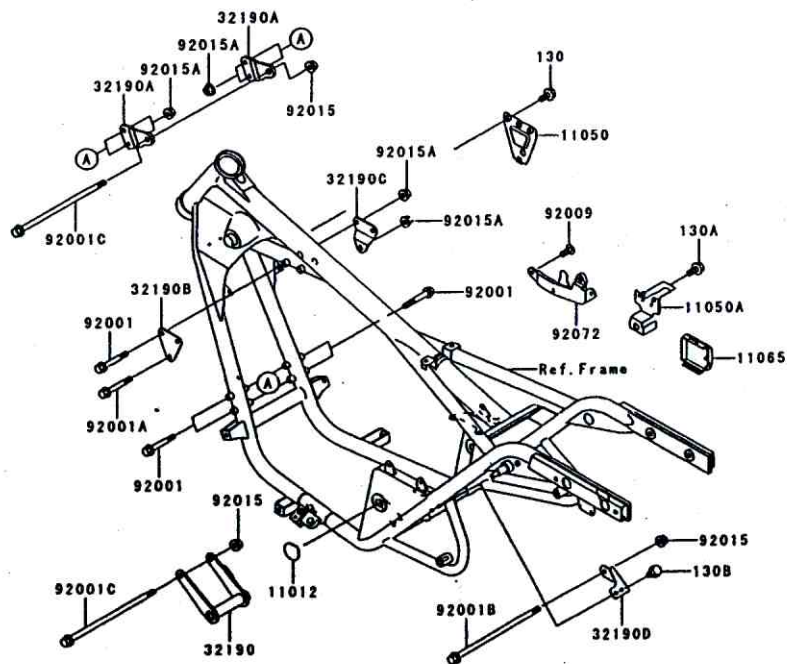

Ref. No.	Part No.	Description	Spec Code	Quantity-BN175			
				'99	'00	A2	A3
11012	11012-1821	CAP,PIVOT		2	2		
11050	11050-1383	BRACKET,IGNITER		1	1		
11050A	11050-1526	BRACKET,ELECTRIC		1	1		
11065	11065-1068	CAP,TOOL CASE		1	1		
32190	32190-1092	BRACKET-ENGINE,RR		1	1		
32190A	32190-1093	BRACKET-ENGINE,FR		2	2		
32190B	32190-1103	BRACKET-ENGINE,HEAD,LH		1	1		
32190C	32190-1104	BRACKET-ENGINE,HEAD,RH		1	1		
32190D	32190-1109	BRACKET-ENGINE		1	1		
92001	92001-1616	BOLT,FLANGED,8X65,BLACK		6	6		
92001A	92001-1641	BOLT,FLANGED,8X55,BLACK		1	1		
92001B	92001-1719	BOLT,FLANGED,10X110		1	1		
92001C	92001-1780	BOLT,FLANGED,10X115,BLACK		2	2		
92009	92009-1621	SCREW,6X16		2	2		
92015	92015-1180	NUT,FLANGED,10MM		3	3		
92015A	92015-1251	NUT,FLANGED,8MM,BLACK		7	7		
92072	92072-1348	BAND		1	1		
130	130J0612	BOLT-FLANGED		2	2		
130A	130J0616	BOLT-FLANGED,6X16,BLACK		2	2		
130B	130J0620	BOLT-FLANGED,8X20		2	2		

This catalog covers:

'99~'00 BN175-A2/A3 Chassis

GRID NO.

D-5

This grid covers:

Swingarm



F2141

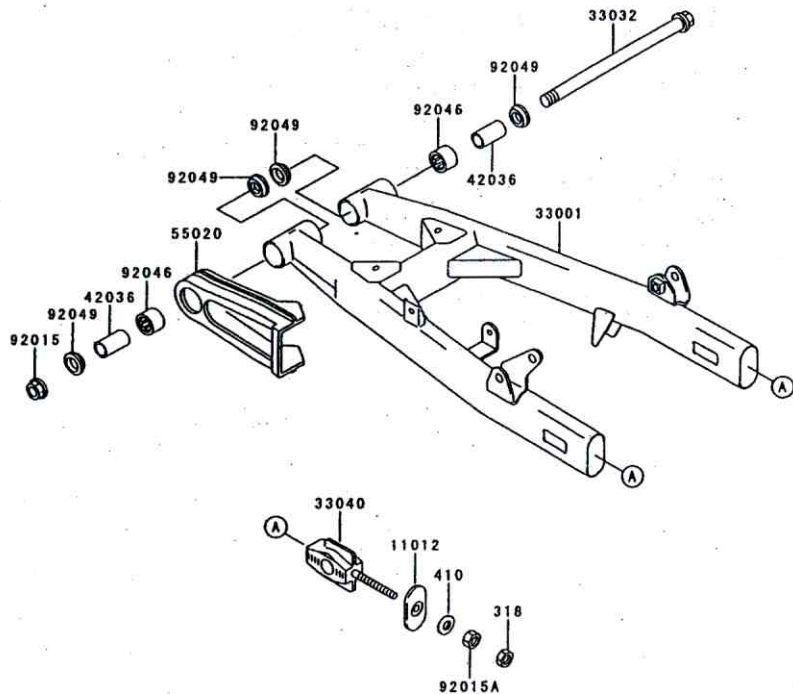

Ref. No.	Part No.	Description	Spec Code	Quantity-BN175			
				'99	'00		
				A2	A3		
11012	11012-1819	CAP,CHAIN ADJUSTER		2	2		
33001	33001-1599	ARM-COMP-SWING		1	1		
33032	33032-1109	SHAFT-SWING ARM		1	1		
33040	33040-1178	ADJUSTER-CHAIN,INNER		2	2		
42036	42036-1338	SLEEVE,14.1X22X57		2	2		
55020	55020-1689	GUARD,CHAIN		1	1		
92015	92015-1407	NUT,14MM		1	1		
92015A	92015-1959	NUT,8MM		2	2		
92046	92046-1174	BEARING-NEEDLE,TA2230Z		2	2		
92049	92049-1289	SEAL-OIL,MHA22X29X5.7F		4	4		
318	318C0800	NUT-HEX-SMALL		2	2		
410	410F0800	WASHER-PLAIN-SMALL,8MM,BLACK		2	2		

This catalog covers:

'99~'00 BN175-A2/A3 Chassis

GRID NO.

This grid covers:

D-6

Suspension/Shock Absorber



F2151

Ref. No.	Part No.	Description	Spec Code	Quantity-BN175		
				'99 A2	'00 A3	
45014	45014-1685	SHOCKABSORBER		2	2	
45016	45016-008	COLLAR,SHOCKABSORBER		2	2	
45017	45017-012	DAMPER,SHOCKABSORBER		2	2	
45017A	45017-015	DAMPER,SHOCKABSORBER		2	2	
92020	92020-003	NUT,CAP,10MM		2	2	
92022	92022-044	WASHER,10.5X26X2.3		2	2	
92022A	92022-1540	WASHER,SPRING,10MM		2	2	
92150	92150-1297	BOLT,FLANGED,10X38		2	2	

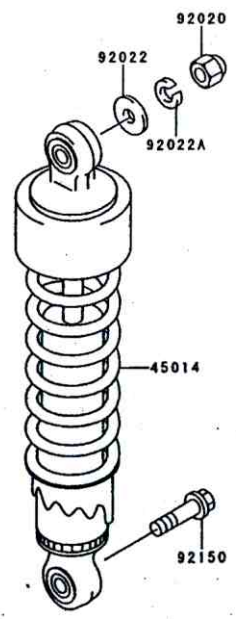
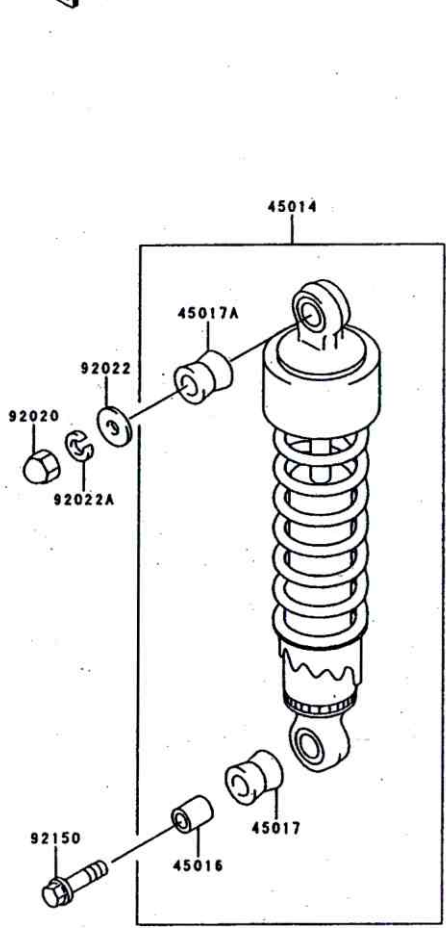

This catalog covers:

'99~'00 BN175-A2/A3 Chassis

GRID NO.

D-7

This grid covers:

Footrests

F2160

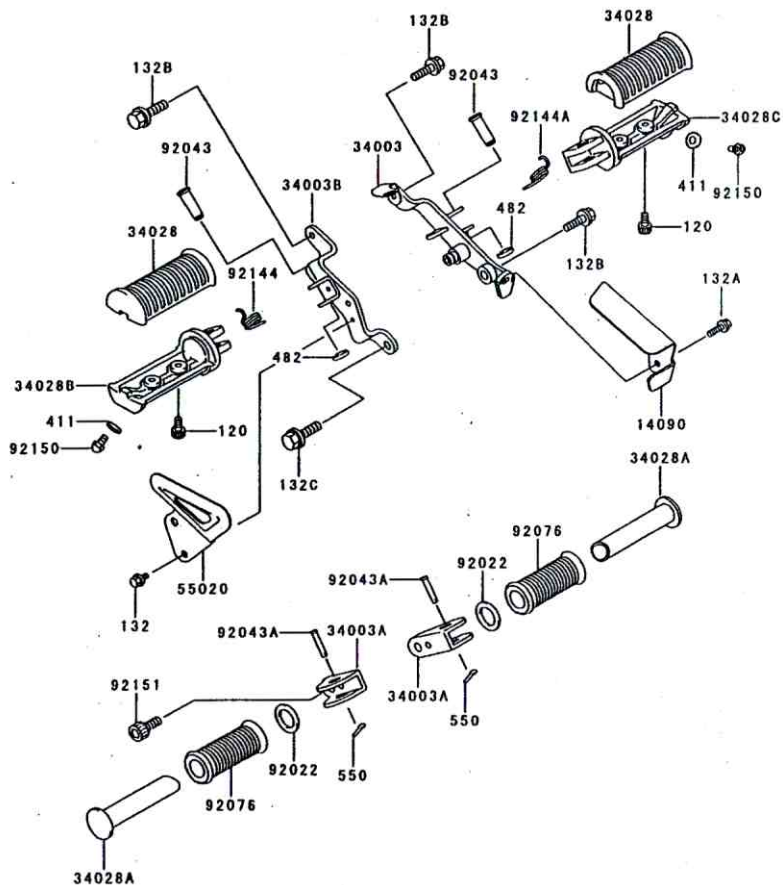

Ref. No.	Part No.	Description	Quantity-BN175			
			'99	'00		
			A2	A3		
14090	14090-1937	COVER,CABLE	1	1		
34003	34003-1465	HOLDER-STEP,FR,RH	1	1		
34003A	34003-1486	HOLDER-STEP,RR	2	2		
34003B	34003-1490	HOLDER-STEP,FR,LH	1	1		
34028	34028-1372	STEP,RUBBER	2	2		
34028A	34028-1373	STEP,RR	2	2		
34028B	34028-1495	STEP,FR,LH	1	1		
34028C	34028-1496	STEP,FR,RH	1	1		
55020	55020-1682	GUARD,HEAT	1	1		
92022	92022-1568	WASHER,20X30X2.3	2	2		
92043	92043-1144	PIN,12X37	2	2		
92043A	92043-1581	PIN,6X30.5	2	2		
92076	92076-020	DAMPER	2	2		
92144	92144-1567	SPRING,STEP RETURN,LH	1	1		
92144A	92144-1568	SPRING,STEP RETURN	1	1		
92150	92150-1153	BOLT,BANK SENSER	2	2		
92151	92151-1422	BOLT,SOCKET,10X20	2	2		
120	120S0512	BOLT-SOCKET	4	4		
132	132E0610	BOLT-FLANGED-SMALL	1	1		
132A	132J0610	BOLT-FLANGED-SMALL,6X10	1	1		
132B	132J0820	BOLT-FLANGED-SMALL	3	3		
132C	132J0830	BOLT-FLANGED-SMALL	1	1		
411	411F0600	WASHER-PLAIN,6MM,BLACK	2	2		
482	482L0100	CIRCLIP-TYPE-E,10MM	2	2		
550	550D2018	PIN-COTTER,2.0X18	2	2		

This catalog covers:

'99~'00 BN175-A2/A3 Chassis

GRID NO.

This grid covers:

D-10

Fenders(BN175-A3)

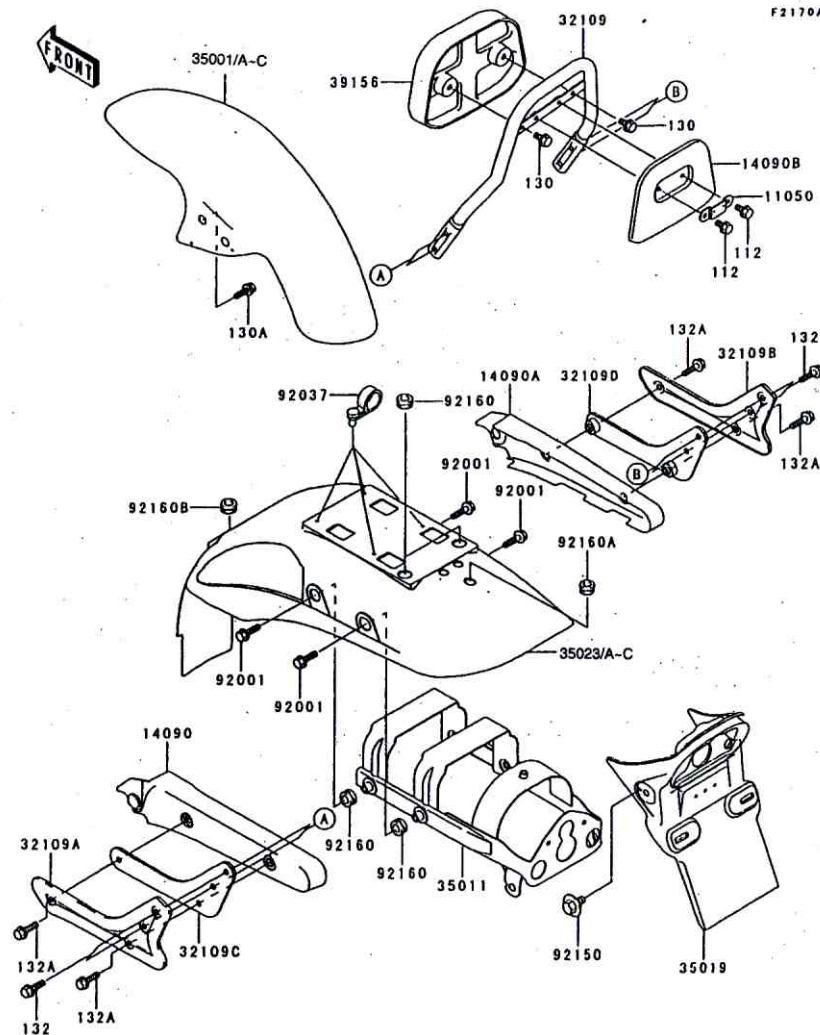

Ref. No.	Part No.	Description	Spec Code	Quantity-BN175			
				'99	'00		
				A2	A3		
11050	11050-1741	BRACKET,REAR GRIP				1	
14090	14090-1836	COVER,REAR FENDER,LH				1	
14090A	14090-1837	COVER,REAR FENDER,RH				1	
14090B	14090-1856	COVER,PAD				1	
32109	32109-1263	GRIP-FRAME,UPP				1	
32109A	32109-1275	GRIP-FRAME,LWR,LH				1	
32109B	32109-1277	GRIP-FRAME,LWR,RH				1	
32109C	32109-1294	GRIP-FRAME,LWR,LH,BASE				1	
32109D	32109-1295	GRIP-FRAME,LWR,RH,BASE				1	
35001	35001-1192-RB	FENDER-ASSY-FRONT,P.BOULOGNE				1	
35001A	35001-1192-US	FENDER-ASSY-FRONT,C.A. RED MICA				1	
35001B	35001-1192-Y5	FENDER-ASSY-FRONT,M.VIOLET				1	
35001C	35001-1192-8W	FENDER-ASSY-FRONT,J.BLACK				1	
35011	35011-1860	STAY,REAR FENDER				1	
35019	35019-1358	FLAP				1	
35023	35023-1496-JB	FENDER-REAR,BLACK/BLACK				1	
35023A	35023-1496-T5	FENDER-REAR,BOULOGNE/BLACK				1	
35023B	35023-1496-UR	FENDER-REAR,VIOLET/BLACK				1	
35023C	35023-1496-UT	FENDER-REAR,RED/BLACK				1	
39156	39156-1581	PAD-SEAT				1	
92001	92001-1178	BOLT,FLANGED,8x38				4	
92037	92037-1163	CLAMP,SPEED,L=58				4	
92150	92150-1133	BOLT,6x14				2	
92160	92160-1847	DAMPER				6	
92160A	92160-1864	DAMPER				1	
92160B	92160-1893	DAMPER				1	
112	112G0612	BOLT-UPSET,6x12				2	
130	130J0612	BOLT-FLANGED				2	
130A	130J0812	BOLT-FLANGED				4	
132	132E0820	BOLT-FLANGED-SMALL				4	
132A	132E0830	BOLT-FLANGED-SMALL				4	

This catalog covers:

'99~'00 BN175-A2/A3 Chassis

GRID NO.

This grid covers:

D-11

Stand(s)



F2190

Ref. No.	Part No.	Description	Spec Code	Quantity-BN175				
				'99	'00			
				A2	A3			
34024	34024-1353	STAND-SIDE			1	1		
92015	92015-1188	NUT, KOCK,10M.M.BLACK			1	1		
92144	92144-1008	SPRING, SIDE STAND			1	1		
92150	92150-1975	BOLT, SIDE STAND			1	1		

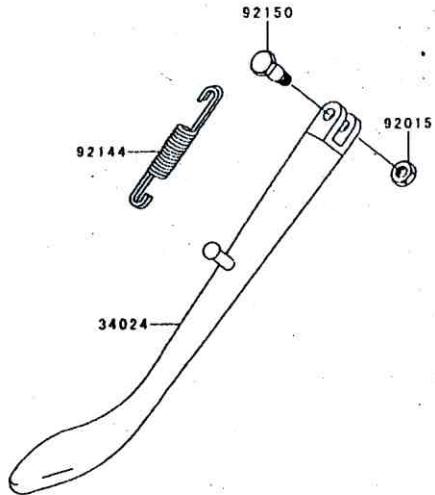

This catalog covers:

'99~'00 BN175-A2/A3 Chassis

GRID NO. This grid covers:

D-12 Tires

F2210

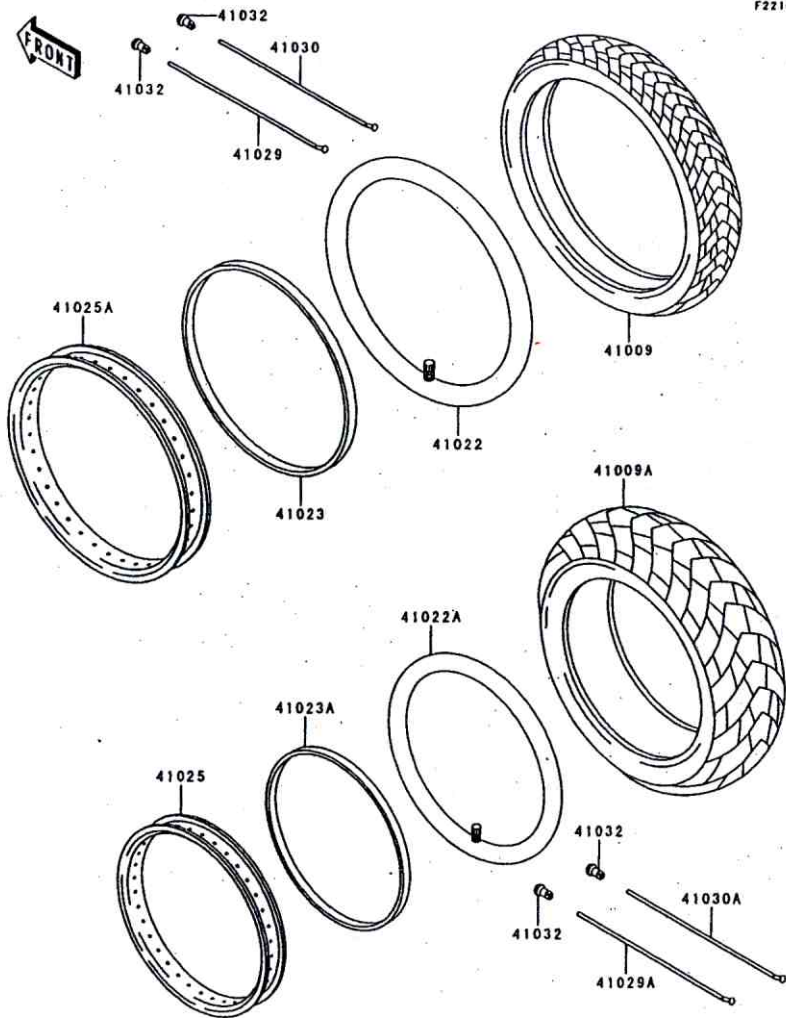

Ref. No.	Part No.	Description	Spec Code	Quantity-BN175			
				'99	'00	A2	A3
41009	41070-9017-NF53/18	TIRE,FR, 90/90-17, NF53 (PISTA)		1	1		
41009A	41070-1315-NR67/18	TIRE, RR, 130/90-15 M/C 66P, NR67 (PISTA)		1	1		
41022	41022-1168	TUBE-TIRE, 2.75-17		1	1		
41022A	41022-1206	TUBE-TIRE, 130/90-15		1	1		
41023	41023-1126	BAND-RIM, 22-17		1	1		
41023A	41023-1127	BAND-RIM, 28-15		1	1		
41025	41025-1351	RIM, RR 2.75X15		1	1		
41025A	41025-1405	RIM, FR 1.85X17		1	1		
41029	41029-1280	SPOKE-INNER, FR,173MMX115D		18	18		
41029A	41029-1281	SPOKE-INNER, RR, 96.5MMX153D		18	18		
41030	41030-1154	SPOKE-OUTER, FR,168.5MMX116D		18	18		
41030A	41030-1155	SPOKE-OUTER, RR,94.5MMX155D		18	18		
41032	41032-1080	NIPPLE-SPOKE		72	72		

This catalog covers:

'99~'00 BN175-A2/A3 Chassis

GRID NO.

D-13

This grid covers:

Front Hub

F2230

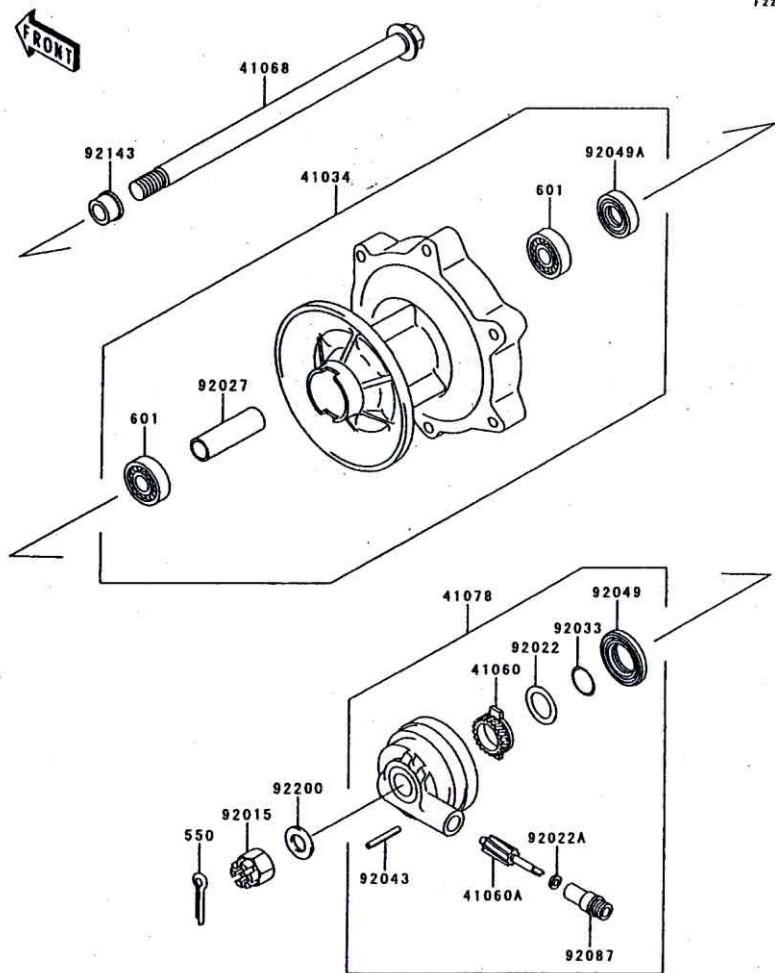

Ref. No.	Part No.	Description	Spec Code	Quantity-BN175			
				'99	'00		
				A2	A3		
41034	41034-1312	DRUM-ASSY,FRONT BRAKE					1
41060	41060-1133	GEAR-METER SCREW,20T					1 1
41060A	41060-1134	GEAR-METER SCREW,8T					1 1
41068	41068-1421	AXLE,FR					1 1
41078	41078-1087	CASE-ASSY-METER GEAR					1 1
92015	92015-1765	NUT,CASTLE,14MM					1 1
92022	92022-1510	WASHER,20X29X1.0					1 1
92022A	92022-1511	WASHER,5X9.5X0.8					1 1
92027	92027-1866	COLLAR,L=70					1 1
92033	92033-1160	RING-SNAP,19MM					1 1
92043	92043-1220	PIN,SPRING,2X14					1 1
92049	92049-1173	SEAL-OIL,SD42X50X6					1 1
92049A	92049-1348	SEAL-OIL,22X35X8					1 1
92087	92087-1051	BUSHING-METER GEAR					1 1
92143	92143-1949	COLLAR,FR AXLE,L=23.5					1 1
92200	92200-1366	WASHER,15X30X3.2					1 1
550	550D3025	PIN-COTTER, 3.0X25					1 1
601	601B6202G	BEARING-BALL,#6202G					2 2

This catalog covers:

'99~'00 BN175-A2/A3 Chassis

GRID NO.

D-14

This grid covers:

Rear Hub

F2240

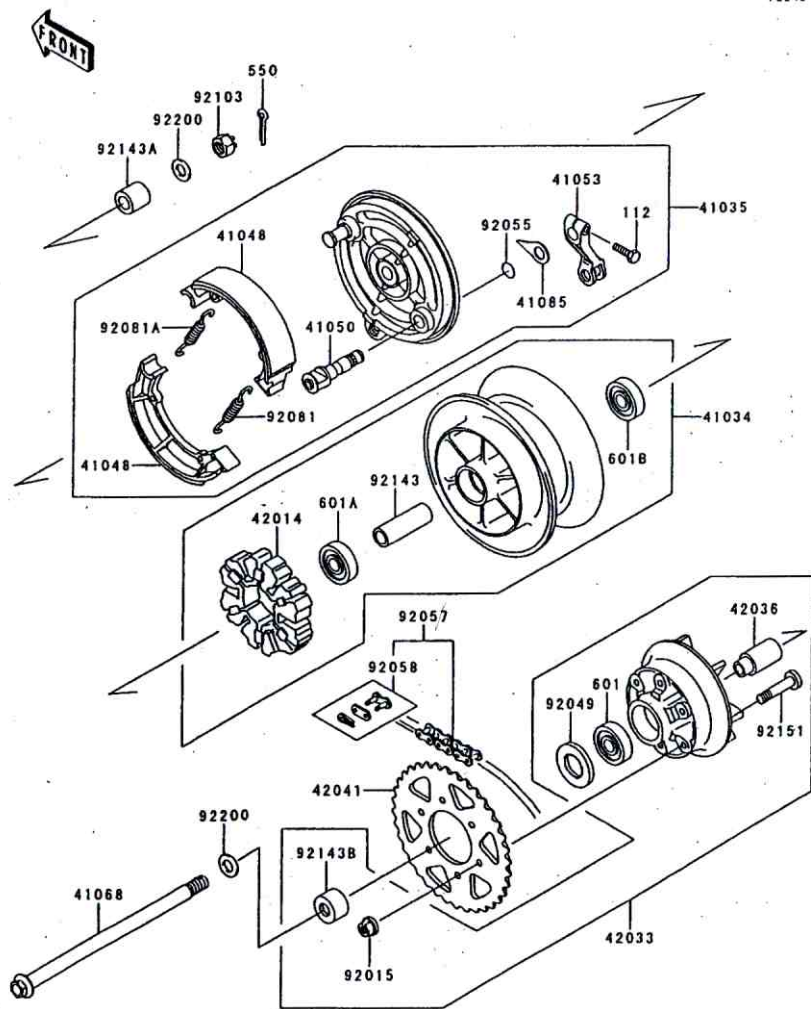

Ref. No.	Part No.	Description	Spec Code	Quantity-BN175			
				'99	'00		
				A2	A3		
41034	41034-1318	DRUM-ASSY,REAR BRAKE		1			
41035	41035-1504	PANEL-ASSY-BRAKE,RR		1	1		
41048	41048-1025	SHOE-BRAKE,RR		2	2		
41050	41050-1096	CAM-BRAKE		1	1		
41053	41053-1087	LEVER-BRAKE CAM		1	1		
41068	41068-1392	AXLE,RR		1	1		
41085	41085-013	INDICATOR,BRAKE SHOE		1	1		
42014	42014-030	DAMPER,REAR HUB SHOCK		1	1		
42033	42033-1202	COUPLING-ASSY,RR HUB		1	1		
42036	42036-030	SLEEVE,RR HUB COUPLING		1	1		
42041	42041-1518	SPROCKET-HUB,42T		1	1		
92015	92015-1668	NUT,FLANGED,LOCK,8MM		6	6		
92049	92049-1487	SEAL-OIL,KCY26X42X8		1	1		
92055	92055-044	RING-O,BRAKE CAM		1	1		
92057	92057-1299	CHAIN,DRIVE,EK428SH-RX130L		1	1		
92058	92058-1058	JOINT-CHAIN		1	1		
92081	92081-1550	SPRING,BRAKE SHOE		1	1		
92081A	92081-1766	SPRING,BRAKE SHOE		1	1		
92103	92103-066	NUT,CASTLE,14MM		1	1		
92143	92143-1014	COLLAR,REAR BRAKE DRUM,L=100		1	1		
92143A	92143-1950	COLLAR,RR AXLE,L=34.5		1	1		
92143B	92143-1951	COLLAR,RR HUB COUPLING,L=20		1	1		
92151	92151-1320	BOLT,8X41		6	6		
92200	92200-1366	WASHER,15X30X3.2		2	2		
112	112P0622	BOLT-UPSET,6X22		1	1		
550	550D4035	PIN-COTTER,4.0X35		1	1		
601	601B6004UU	BEARING-BALL,#6004UUC3		1	1		
601A	601B6202UU	BEARING-BALL		1	1		
601B	601B6302UU	BEARING-BALL,#6302UU		1	1		

This catalog covers:

'99~'00 BN175-A2/A3 Chassis

GRID NO.

E-3

This grid covers:

Brake Pedal

F2260

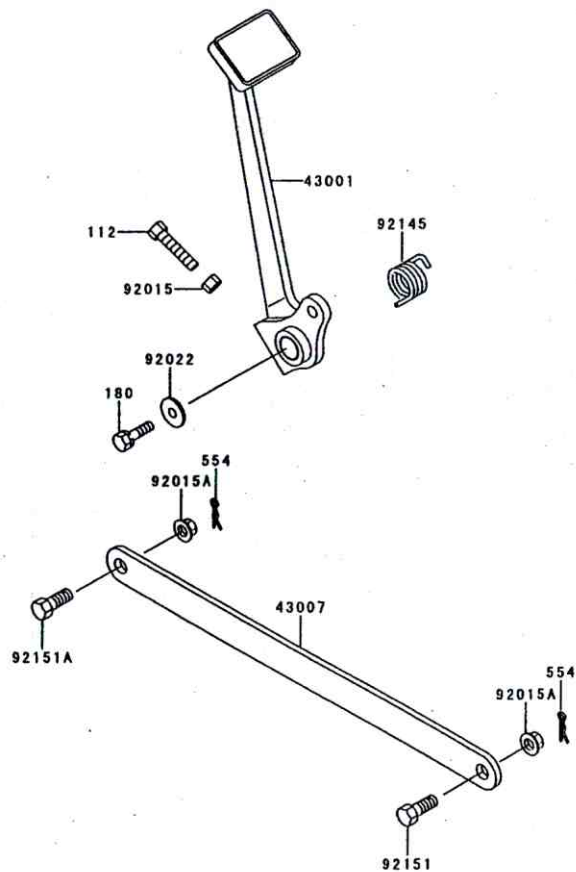

Ref. No.	Part No.	Description	Spec Code	Quantity-BN175			
				'99	'00	A2	A3
43001	43001-1404	LEVER-BRAKE,PEDAL		1	1		
43007	43007-1037	ROD-TORQUE		1	1		
92015	92015-1391	NUT,6MM		1	1		
92015A	92015-1428	NUT,FLANGED,10MM		2	2		
92022	92022-1346	WASHER,6.5X20X1.6,BLACK		1	1		
92145	92145-1072	SPRING,BRAKE PEDAL RETURN		1	1		
92151	92151-1203	BOLT,10X27		1	1		
92151A	92151-1337	BOLT,FLANGED,10X25		1	1		
112	112G0630	BOLT-UPSET		1	1		
180	180J0616	BOLT-UPSET-WS,6X16		1	1		
554	554A0800	PIN-SNAP,8MM		2	2		

This catalog covers:

'99~'00 BN175-A2/A3 Chassis

GRID NO.

E-4

This grid covers:

Front Master Cylinder

F2291

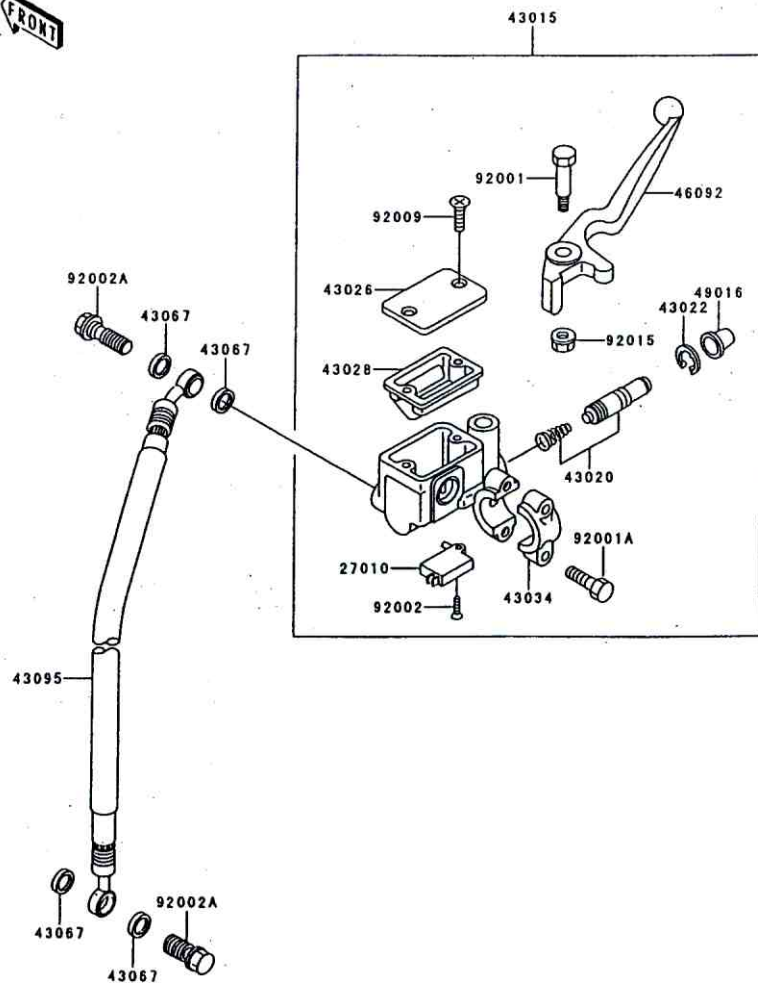

Ref. No.	Part No.	Description	Spec Code	Quantity-BN175			
				'99	'00	A2	A3
27010	27010-1170	SWITCH,BRAKE		1	1		
43015	43015-1664	CYLINDER-ASSY-MASTER,FR		1	1		
43020	43020-1095	PISTON-COMP-BRAKE		1	1		
43022	43022-1010	STOPPER-BRAKE,PISTON		1	1		
43026	43026-1074	CAP-BRAKE		1	1		
43028	43028-1061	DIAPHRAGM		1	1		
43034	43034-1016	HOLDER-BRAKE,MASTER CYLINDER		1	1		
43067	43067-001	WASHER,10.5X15X1.5		4	4		
43095	43095-1136	HOSE-BRAKE,FR		1	1		
46092	46092-1203	LEVER-GRIP,FRONT BRAKE		1	1		
49016	49016-1044	COVER-SEAL,MASTER CYLINDER		1	1		
92001	92001-1728	BOLT,FRONT BRAKE LEVER		1	1		
92001A	92001-1729	BOLT,6X25,BLACK		2	2		
92002	92002-1323	BOLT,SCREW,4X12		1	1		
92002A	92002-1888	BOLT,OIL,L=23		2	2		
92009	92009-1458	SCREW,4MM		2	2		
92015	92015-1233	NUT,FLANGED,6MM,BLACK		1	1		

This catalog covers:

'99~'00 BN175-A2/A3 Chassis

GRID NO.

E-5

This grid covers:

Front Brake

FRONT

F2292

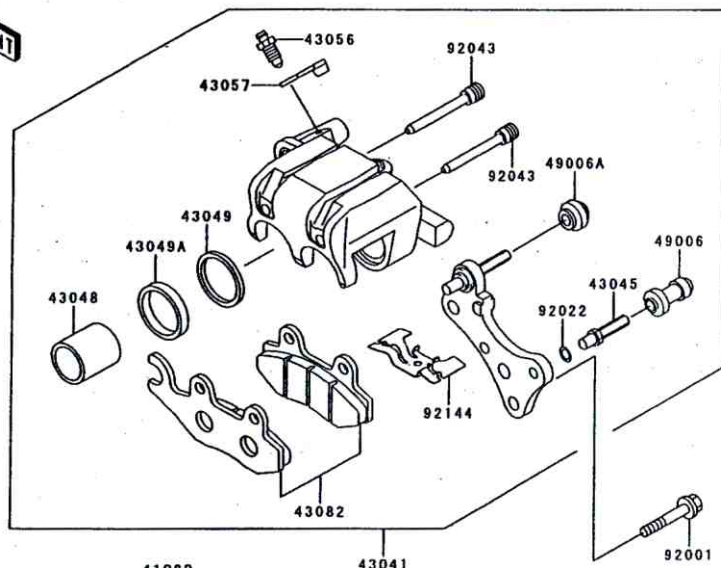

Ref. No.	Part No.	Description	Spec Code	Quantity-BN175			
				'99	'00		
				A2	A3		
41080	41080-1451	DISC,FR		1	1		
43041	43041-1695	CALIPER-ASSY,FR		1	1		
43045	43045-1010	SHAFT-CALIPER		1	1		
43048	43048-1068	PISTON-CALIPER		2	2		
43049	43049-1060	PACKING,PISTON SEAL		2	2		
43049A	43049-1061	PACKING,PISTON SEAL		2	2		
43056	43056-1056	BREATHER-BRAKE		1	1		
43057	43057-1001	CAP-BREATHER		1	1		
43082	43082-1238	PAD-ASSY-BRAKE		1	1		
49006	49006-1088	BOOT,CALIPER		1	1		
49006A	49006-1242	BOOT,CALIPER		1	1		
92001	92001-1041	BOLT,FLANGED,8X36		2	2		
92022	92022-1373	WASHER,WAVE		1	1		
92043	92043-1416	PIN,HANGER		2	2		
92144	92144-1557	SPRING,PAD		1	1		
92150	92150-1858	BOLT,DISC PLATE,8X25		6	6		

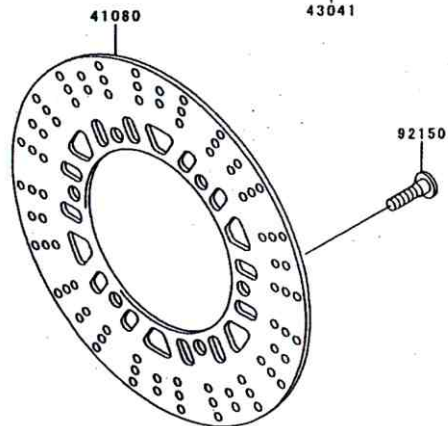

This catalog covers:

'99~'00 BN175-A2/A3 Chassis

GRID NO.

E-7

This grid covers:

Handlebar(BN175-A3)

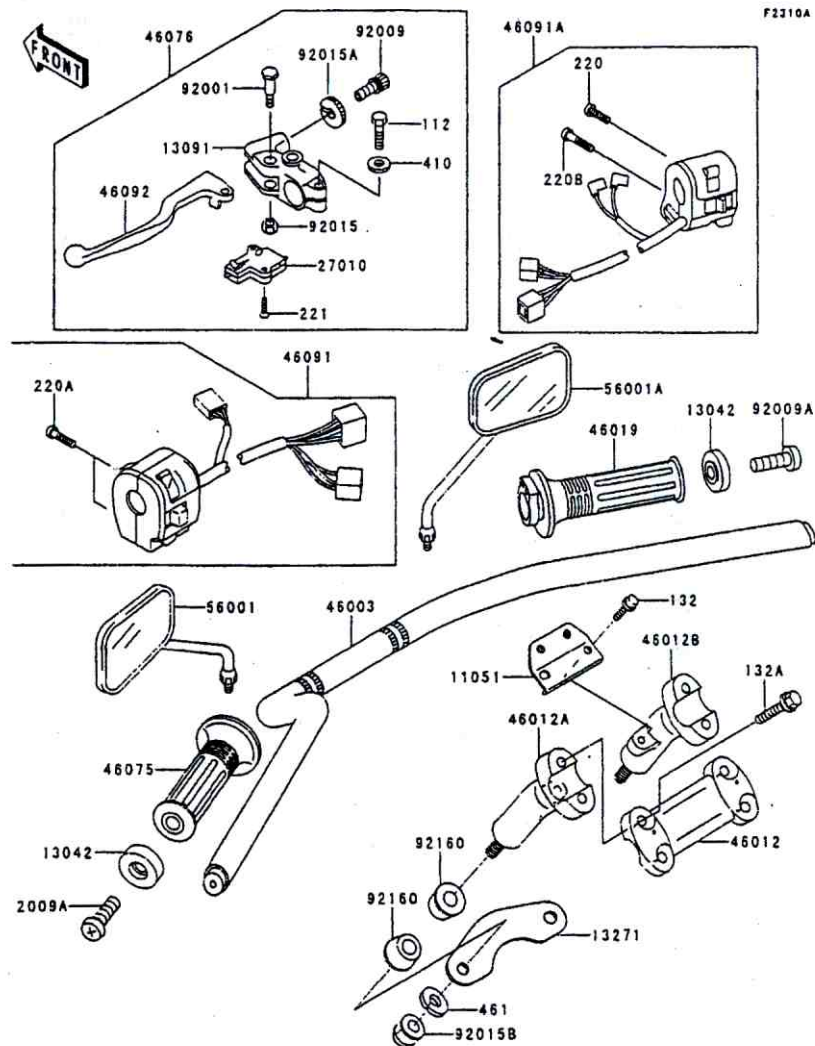

F2210A

Ref. No.	Part No.	Description	Spec Code	Quantity-BN175			
				'99	'00	A2	A3
11051	11051-1679	BRACKET					1
13042	13042-1126	WEIGHT,HANDLE					2
13091	13091-1272	HOLDER,CLUTCH LEVER					1
13271	13271-1534	PLATE					1
27010	27010-1094	SWITCH,CLUTCH,BLACK					1
46003	46003-1543	HANDLE					1
46012	46012-1321	HOLDER-HANDLE,UPP					1
46012A	46012-1322	HOLDER-HANDLE,LWR,LH					1
46012B	46012-1323	HOLDER-HANDLE,LWR,RH					1
46019	46019-1107	GRIP-ASSY,THROTTLE					1
46075	46075-1080	GRIP,LH					1
46076	46076-1222	LEVER-ASSY-GRIP,CLUTCH					1
46091	46091-1768	HOUSING-ASSY-CONTROL,LH					1
46091A	46091-1771	HOUSING-ASSY-CONTROL,RH					1
46092	46092-1206	LEVER-GRIP,CLUTCH					1
56001	56001-1523	MIRROR-ASSY,LH					1
56001A	56001-1524	MIRROR-ASSY,RH					1
92001	92001-1548	BOLT,CLUTCH LEVER,BLACK					1
92009	92009-1134	SCREW,CABLE ADJUST,8MM,BL ACK					1
92009A	92009-1484	SCREW,8X20					2
92015	92015-1191	NUT,LOCK,6MM,BLACK					1
92015A	92015-1197	NUT,CABLE ADJUST LOCK,8MM,BLK					1
92015B	92015-1961	NUT,CAP,10MM					2
92160	92160-1957	DAMPER,HANDLE HOLDER					4
112	112J0622	BOLT-UPSET					1
132	132E0616	BOLT-FLANGED-SMALL					2
132A	132E0830	BOLT-FLANGED-SMALL					4
220	220C0525	SCREW-PAN-CROS					1
220A	220C0530	SCREW-PAN-CROS					2
220B	220C0540	SCREW-PAN-CROS					1
221	221C0316	SCREW-CSK-CROS					2
410	410F0600	WASHER-PLAIN-SMALL,6MM,BLACK					1
461	461F1000	WASHER-SPRING,10MM					2

This catalog covers:

'99~'00 BN175-A2/A3 Chassis

GRID NO.

E-8

This grid covers:

Front Fork

F2340

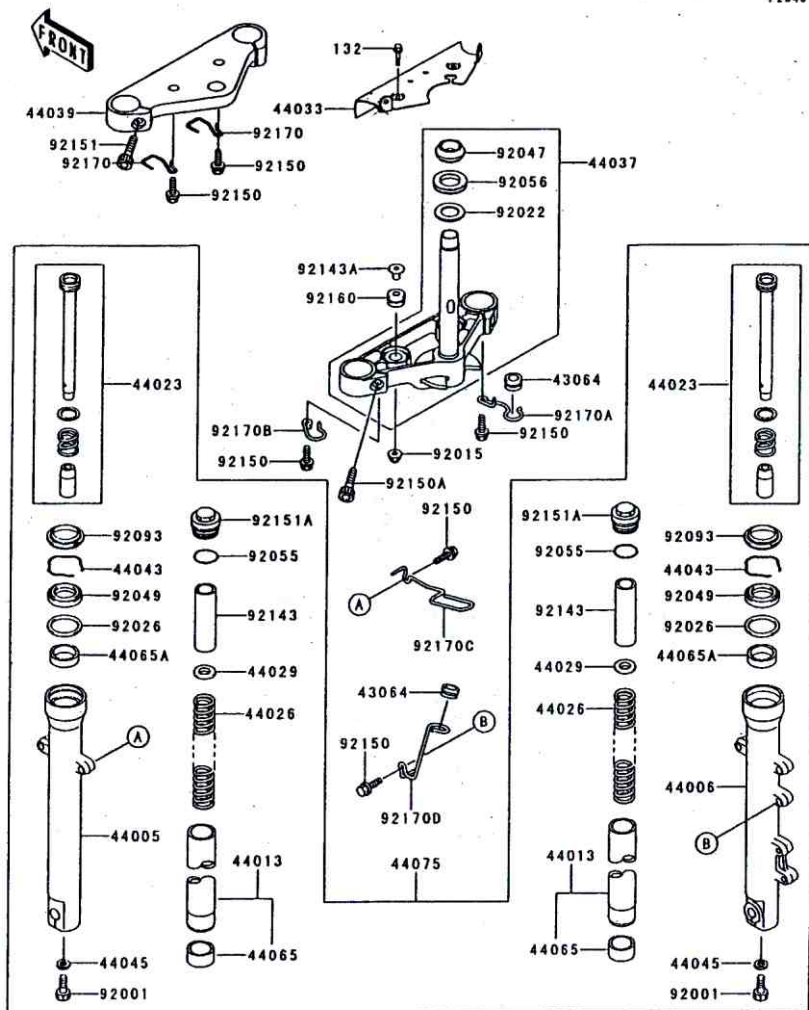

Ref. No.	Part No.	Description	Spec Code	Quantity-BN175			
				'99	'00	A2	A3
43064	43064-007	GROMMET,HOSE CLAMP		2	2		
44005	44005-1391	PIPE-LEFT FORK OUTER		1	1		
44006	44006-1390	PIPE-RIGHT FORK OUTER		1	1		
44013	44013-1444	PIPE-FORK INNER		2	2		
44023	44023-1128	CYLINDER-SET-FORK		2	2		
44026	44026-1680	SPRING-FRONT FORK		2	2		
44029	44029-1136	SEAT-FORK SPRING		2	2		
44033	44033-1226	COVER-FORK		1	1		
44037	44037-1361	HOLDER-FORK UNDER		1	1		
44039	44039-1286	HOLDER-FORK UPPER		1	1		
44043	44043-057	RING,OIL SEAL STOPPER		2	2		
44045	44045-051	GASKET,FORK CYLINDER BOLT		2	2		
44065	44065-1123	BUSHING-FRONT FORK,INNER PIPE		2	2		
44065A	44065-1124	BUSHING-FRONT FORK,OUTER TUBE		2	2		
44075	44075-1076	DAMPER-SET-FORK		1	1		
92001	92001-1464	BOLT,FORK CYLINDER		2	2		
92015	92015-1385	NUT,CAP,6MM		2	2		
92022	92022-231	WASHER,30.5X50X0.6		1	1		
92026	92026-1365	SPACER		2	2		
92047	92047-012	RACE,STEERING STEM BEARING		1	1		
92049	92049-1340	SEAL-OIL,FORK OUTER TUBE		2	2		
92055	92055-1367	RING-O,FORK TOP		2	2		
92056	92056-003	SEAL-OIL,STEERING STEM		1	1		
92093	92093-1280	SEAL,FORK OUTER TUBE		2	2		
92143	92143-1311	COLLAR,FORK		2	2		
92143A	92143-1683	COLLAR,L=12		2	2		
92150	92150-1340	BOLT,6X14		6	6		
92150A	92150-1387	BOLT,SOCKET,10X25		2	2		
92151	92151-1261	BOLT		2	2		
92151A	92151-1262	BOLT,FORK TOP		2	2		
92160	92160-1167	DAMPER		2	2		
92170	92170-1769	CLAMP,CABLE		2	2		
92170A	92170-1840	CLAMP,HOSE		1	1		
92170B	92170-1841	CLAMP,CABLE		1	1		
92170C	92170-1892	CLAMP,CABLE		1	1		
92170D	92170-1948	CLAMP		1	1		
132	132E0620	BOLT-FLANGED-SMALL		2	2		

This catalog covers:

'99~'00 BN175-A2/A3 Chassis

GRID NO.

E-9

This grid covers:

Fuel Tank

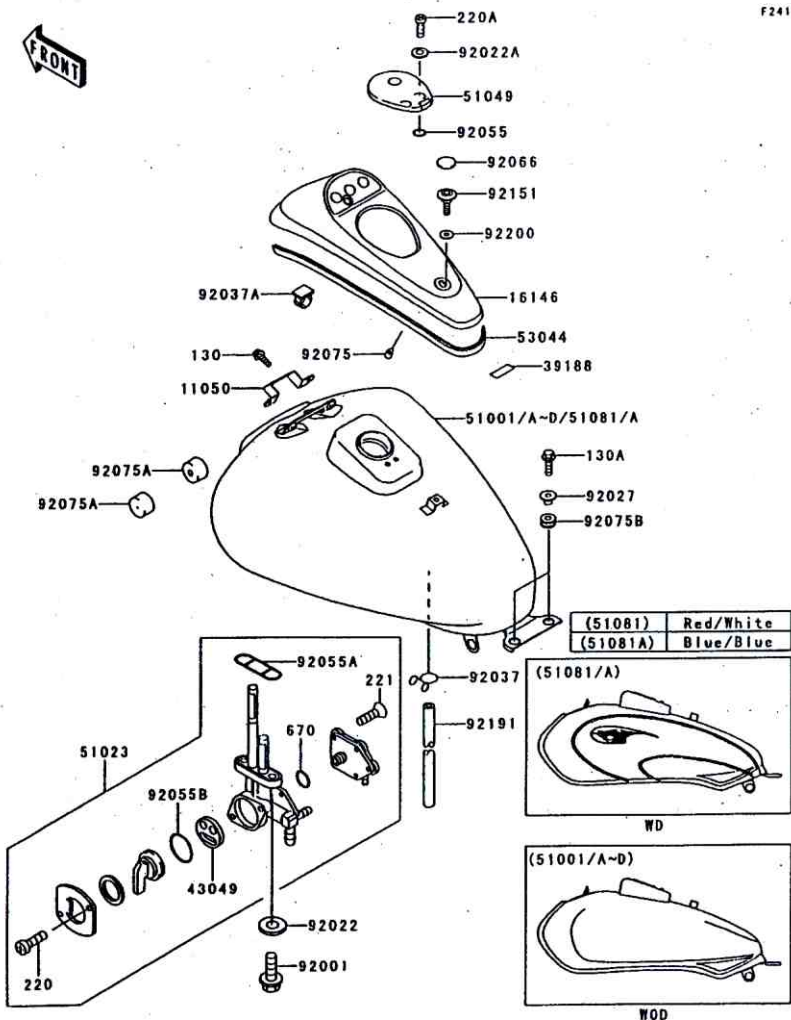

F2410

Ref. No.	Part No.	Description	Spec Code	Quantity-BN175			
				'99	'00		
				A2	A3		
11050	11050-1433	BRACKET, FUEL TANK COVER	1	1			
16146	16146-1190	COVER-ASSY,FUEL TANK	1	1			
43049	43049-1066	PACKING, TAP VALVE	1	1			
51001A	51001-1593-R8	TANK-COM-FUEL, P. BOULOGNE	1				
51001B	51001-1593-US	TANK-COM-FUEL, C.A.RED MICA	1				
51001C	51001-1593-Y5	TANK-COM-FUEL, M.VIOLET	1				
51001D	51001-1593-BW	TANK-COM-FUEL, J.BLACK	1				
51023	51023-1236	TAP-ASSY FUEL	1				
51049	51049-1088	CAP-TANK, FUEL	1				
53044	53044-1316	TRIM L=870	1	1			
92001	92001-1524	BOLT 6X25	2	2			
92022	92022-183	WASHER 6.2X11X1.5	2	2			
92022A	92022-1977	WASHER 5.1X10X1.0	2	2			
92027	92027-251	COLLAR L=13.1	2	2			
92037	92037-1712	CLAMP	1	1			
92037A	92037-1194	CLAMP, TUBE	1	1			
92055	92055-1023	RING-O	2	2			
92055A	92055-1112	RING-O, FUEL TAP PACKING	1	1			
92055B	92055-1419	RING-O, TAP LEVER	1	1			
92066	92066-1301	PLUG	2	2			
92075	92075-035	DAMPER	2	2			
92075A	92075-101	DAMPER, FUEL TANK	2	2			
92075B	92075-209	DAMPER	2	2			
92151	92151-1248	BOLT 6MM	2	2			
92191	92191-1302	TUBE 7X10X530	1	1			
92200	92200-1439	WASHER 9.3X18X1.6	2	2			
130	130J0612	BOLT-FLANGED	2	2			
130A	130J0620	BOLT-FLANGED	2	2			
220	220B0308	SCREW-PAN-CROS	2	2			
220A	220D0510	SCREW-PAN-CROS	2	2			
221	221B0414	SCREW-CSK-CROS 4X14	5	5			
670	670B1504	O' RING, 4MM	1	1			

This catalog covers:

'99~'00 BN175-A2/A3 Chassis

GRID NO. This grid covers:

E-10 Seat



F2510

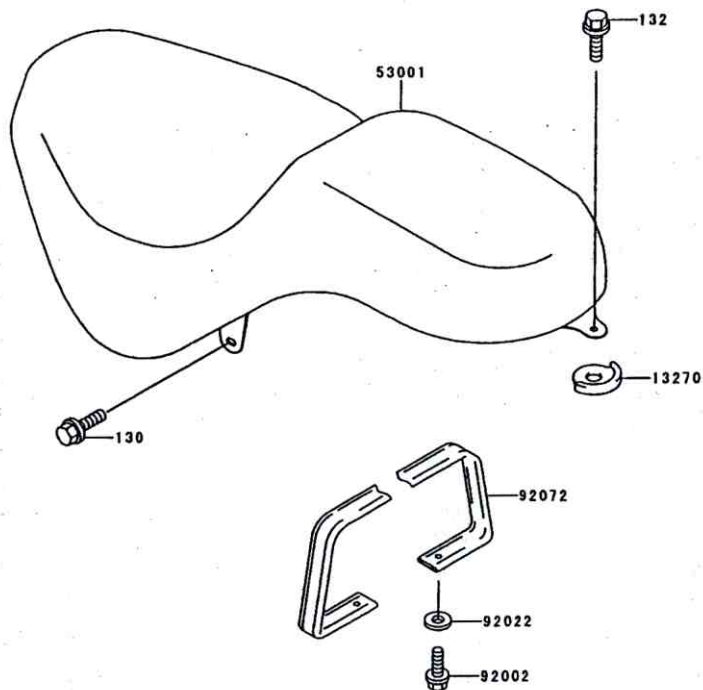

Ref. No.	Part No.	Description	Spec Code	Quantity-BN175			
				'99	'00	A2	A3
13270	13270-1484	PLATE,RR SEAT,FR		1	1		
53001	53001-1905-MA	SEAT-ASSY,DUAL,BLACK		1	1		
92002	92002-1571	BOLT,6X16		2	2		
92022	92022-1557	WASHER,6.5X20X1.6		2	2		
92072	92072-1373	BAND,SEAT		1	1		
130	130J0610	BOLT-FLANGED		2	2		
132	132E0614	BOLT-FLANGED-SMALL,6X14		1	1		

This catalog covers:

'99~'00 BN175-A2/A3 Chassis

GRID NO.

E-11

This grid covers:

Meter(s)

r2530

FRONT

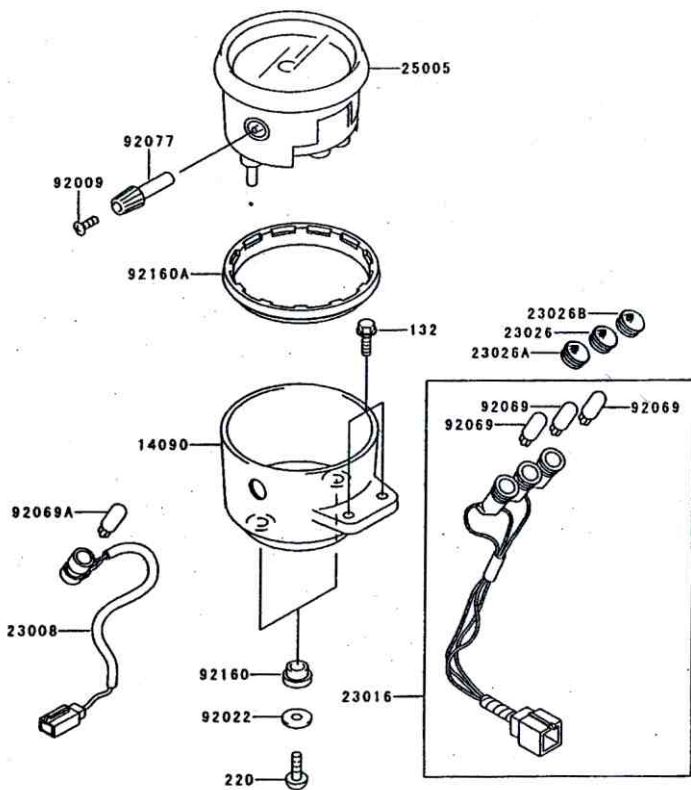

Ref. No.	Part No.	Description	Spec Code	Quantity-BN175			
				'99	'00		
				A2	A3		
14090	14090-1863	COVER,SPEEDOMETER,LWR	1	1			
23008	23008-1606	SOCKET-ASSY,SPEEDOMETER	1	1			
23016	23016-1175	LAMP-ASSY	1	1			
23026	23026-1212	LENS,GREEN	1	1			
23026A	23026-1213	LENS,AMBER	1	1			
23026B	23026-1214	LENS,BLUE	1	1			
25005	25005-1655	SPEEDOMETER,KPH	1	1			
92009	92009-1172	SCREW,2X6,BLACK	1	1			
92022	92022-1822	WASHER,4.5X10X0.8	2	2			
92069	92069-1007	BULB,12V 3.4W,T10	3	3			
92069A	92069-1059	BULB,12V 1.7W,T10	1	1			
92077	92077-1124	KNOB,TRIP	1	1			
92160	92160-1068	DAMPER	2	2			
92160A	92160-1380	DAMPER,SHOCK,METER	1	1			
132	132E0616	BOLT-FLANGED-SMALL	2	2			
220	220E0408	SCREW-PAN-CROS	2	2			

This catalog covers:

'99~'00 BN175-A2/A3 Chassis

GRID NO.

This grid covers:

E-12

Cables

F2540

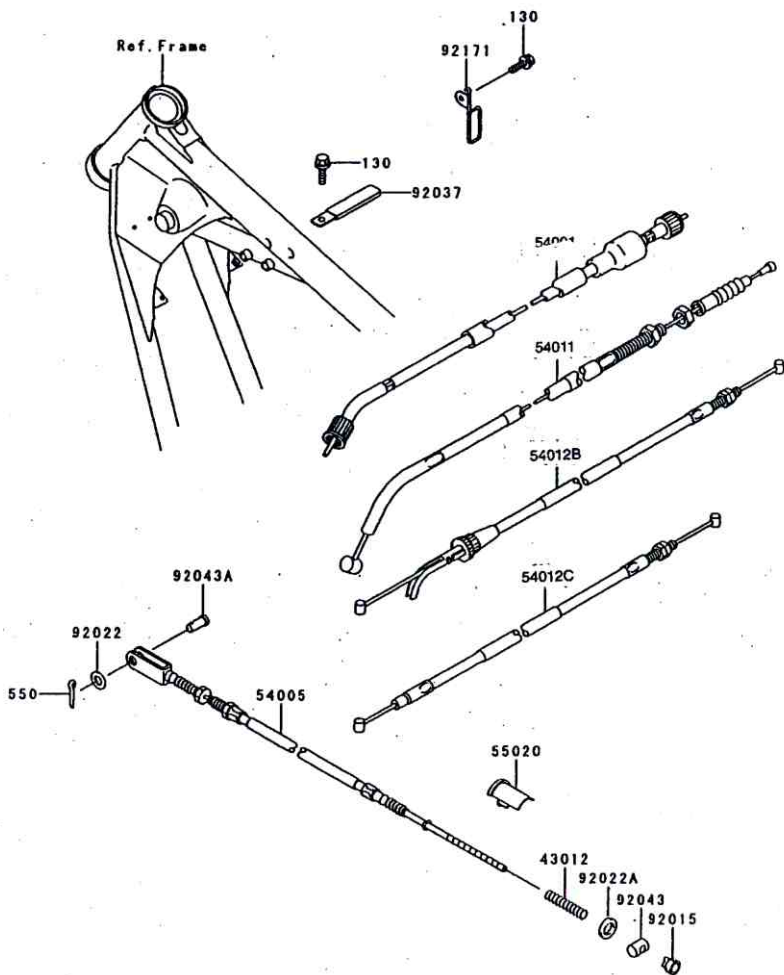

Ref. No.	Part No.	Description	Spec Code	Quantity-BN175			
				'99	'00		
				A2	A3		
43012	43012-001	SPRING, BRAKE ROD		1	1		
54001	54001-1245	CABLE-SPEEDMETER			1		
54005	54005-1208	CABLE-BRAKE		1	1		
54011	54011-1405	CABLE-CLUTCH					
54012B	54012-1627	CABLE-THROTTLE, OPENNING			1		
54012C	54012-1628	CABLE-THROTTLE, CLOSING				1	
55020	55020-1687	GUARD, REAR BRAKE CABLE		1	1		
92015	92015-042	NUT, BRAKE ROD		1	1		
92022	92022-1582	WASHER, 8.5X16X1.2		1	1		
92022A	92022-1588	WASHER, 6.3X10.2X1.6		1	1		
92037	92037-1069	CLAMP, WIRING HARNESS, L=60		1	1		
92043	92043-065	PIN, BRAKE ROD		1	1		
92043A	92043-1013	PIN, 8X16		1	1		
92171	92171-1063	CLAMP, CLUTCH CABLE		1	1		
130	130J0614	BOLT-FLANGED, 6X14, BLACK		2	2		
550	550D2018	PIN-COTTER, 2.0X18		1	1		

This catalog covers:

'99~'00 BN175-A2/A3 Chassis

GRID NO.

This grid covers:

E-13

Side Covers/Chain Cover

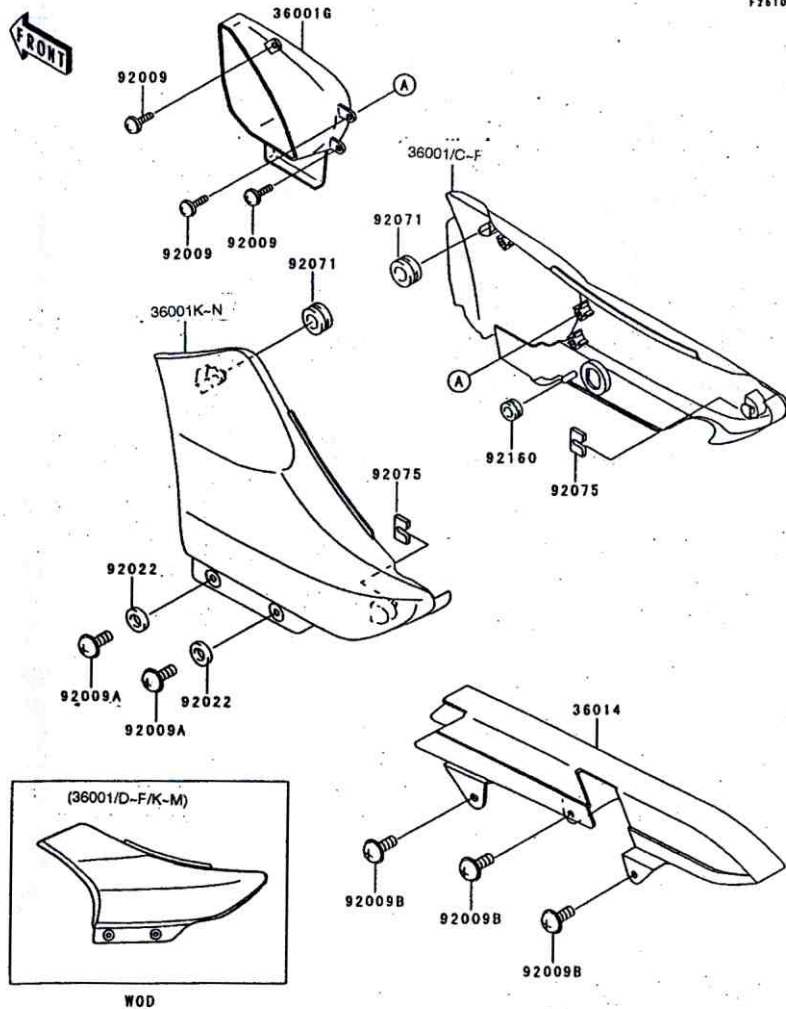

Ref. No.	Part No.	Description	Spec Code	Quantity-BN175			
				'99	'00		
				A2	A3		
36001C	36001-1606-JB	COVER-SIDE, RH BLACK/BLACK		1			
36001D	36001-1606-RB	COVER-SIDE, RH P. BOULOGNE		1			
36001E	36001-1606-US	COVER-SIDE, RH C.A. RED MICA		1			
36001F	36001-1606-Y5	COVER-SIDE, RH M. VIOLET		1			
36001G	36001-1607	COVER-SIDE, RH		1			
36001K	36001-1610-R8	COVER-SIDE, LH P. BOULOGNE		1			
36001L	36001-1610-US	COVER-SIDE, LH C.A. RED MICA		1			
36001M	36001-1610-Y5	COVER-SIDE, LH M. VIOLET		1			
36001N	36001-1610-8W	COVER-SIDE, LH J. BLACK		1			
36014	36014-1228	CASE-CHAIN		1	1		
92009	92009-1197	SCREW, TAPPING 5X14		3	3		
92009A	92009-1287	SCREW 6X14 WHITE		2	2		
92009B	92009-1288	SCREW 6X14		3	3		
92022	92022-1654	WASHER 6.5X16X1.0		2	2		
92071	92071-1043	GROMMET		2	2		
92075	92075-1967	DAMPER		2	2		
92160	92160-1891	DAMPER		1	1		

This catalog covers:

'99~'00 BN175-A2/A3 Chassis

GRID NO.

E-14

This grid covers:

Headlight(s)

F2710

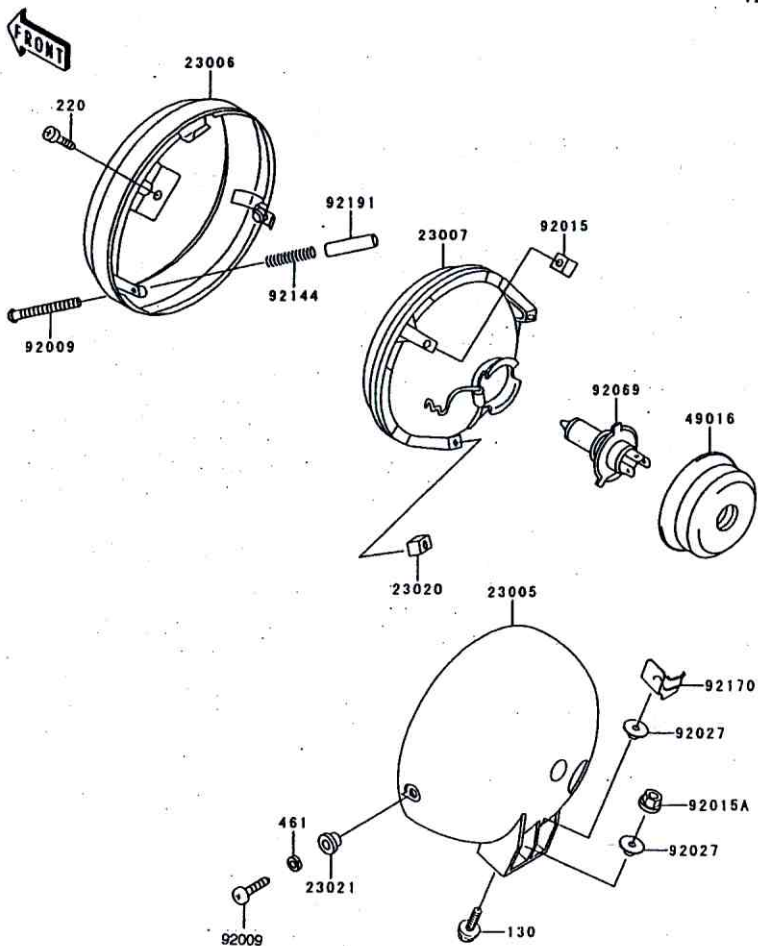

Ref. No.	Part No.	Description	Spec Code	Quantity-BN175			
				'99	'00		
				A2	A3		
23005	23005-1183	BODY-COMP-HEAD LAMP	1	1			
23006	23006-1082	RIM-LAMP	1	1			
23007	23007-1386	LENS-COMP;HEAD LAMP	1	1			
23020	23020-018	NUT,4MM,FOCUS ADJUST	2	2			
23021	23021-010	WASHER	2	2			
49016	49016-1129	COVER-SEAL,HEAD LAMP SOCKET	1	1			
92009	92009-1472	SCREW,FOCUS ADJUST,4X65	2	2			
92009A	92009-1947	SCREW,5MM	2	2			
92015	92015-1157	NUT,5MM	1	1			
92015A	92015-1367	NUT,FLANGED,6MM	1	1			
92027	92027-252	COLLAR,L=6.5	2	2			
92069	92069-1002	BULB,12V 60/55W;H4	1	1			
92144	92144-1149	SPRING,FOCUS ADJUST	2	2			
92170	92170-1624	CLAMP;HARNES	1	1			
92191	92191-1217	TUBE,3.5X4.5X19	2	2			
130	130V0620	BOLT-FLANGED	2	2			
220	220D0512	SCREW-PAN-CROS,5X12	1	1			
461	461F0500	WASHER-SPRING,5MM	2	2			

This catalog covers:

'99~'00 BN175-A2/A3 Chassis

GRID NO.

F-3

This grid covers:

Taillight(s)

F2720

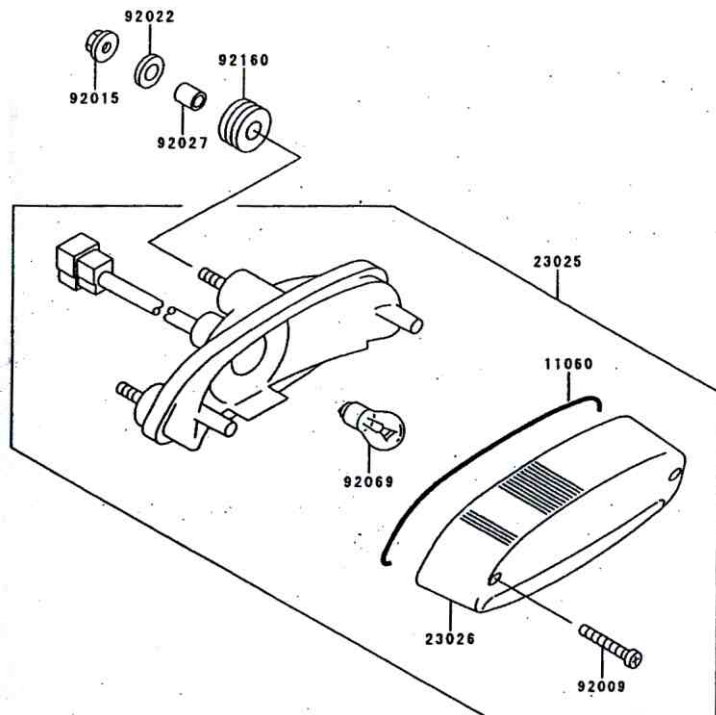

Ref. No.	Part No.	Description	Spec Code	Quantity-BN175			
				'99	'00		
				A2	A3		
11060	11060-1174	GASKET, TAIL LAMP LENS	1	1			
23025	23025-1275	LAMP-TAIL	1	1			
23026	23026-1234	LENS, TAIL LAMP	1	1			
92009	92009-1378	SCREW, TAPPING, 4X20	2	2			
92015	92015-1367	NUT, FLANGED, 6MM	3	3			
92022	92022-1557	WASHER, 6.5X20X1.6	3	3			
92027	92027-162	COLLAR, 6.8X10X12	3	3			
92069	92069-063	BULB, 12V 21/5W	1	1			
92160	92160-1162	DAMPER	3	3			

This catalog covers:

'99~'00 BN175-A2/A3 Chassis

GRID NO.

F-5

This grid covers:

Chassis Electrical Equipment

F2760

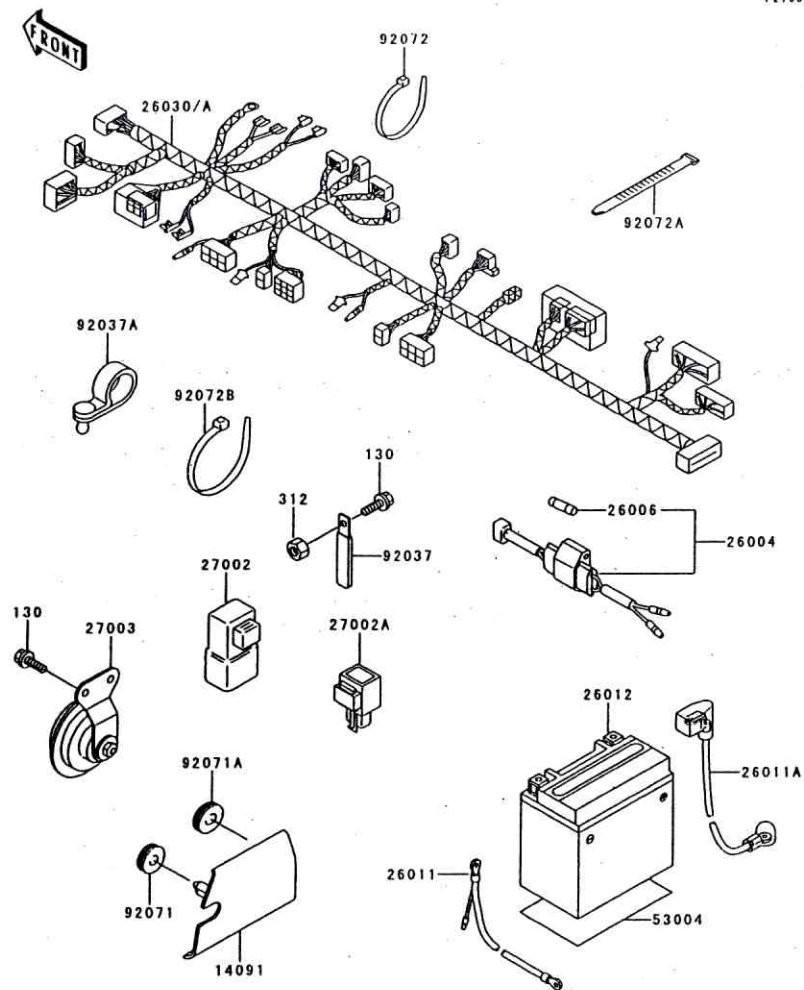

Ref. No.	Part No.	Description	Spec Code	Quantity-BN175			
				'99	'00		
14091	14091-1123	COVER,HEAD GUSSET		1	1		
26004	26004-1113	FUSE-ASSY		1	1		
26006	26006-1003	FUSE,15A,L=30		3	3		
26011	26011-1670	WIRE-LEAD,BATTERY(-)		1	1		
26011A	26011-1674	WIRE-LEAD,BATTERY(+)		1	1		
26012	26012-1367	BATTERY,12N9-4B,12V 9AH		1	1		
26030	26030-1653	HARNES,MAIN		1			
26030A	26030-1749	HARNES,MAIN			1		
27002	27002-1086	RELAY-ASSY,STARTER CIRCUIT		1	1		
27002A	27002-1107	RELAY-ASSY,SIGNAL LAMP		1	1		
27003	27003-1411	HORN		1	1		
53004	53004-1123	MAT,BATTERY		1	1		
92037	92037-1069	CLAMP,WIRING HARNESS,L=60		1	1		
92037A	92037-1163	CLAMP,SPEED,L=58		3	3		
92071	92071-056	GROMMET		1	1		
92071A	92071-1043	GROMMET		1	1		
92072	92072-030	BAND,L=123		2	2		
92072A	92072-1195	BAND,L=185		4	4		
92072B	92072-1197	BAND,L=365		3	3		
130	130J0612	BOLT-FLANGED		3	3		
312	312C0600	NUT-HEX,6MM,BLACK		1	1		

This catalog covers:

'99~'00 BN175-A2/A3 Chassis

GRID NO.

F-4

This grid covers:

Turn Signals

F2730

FRONT

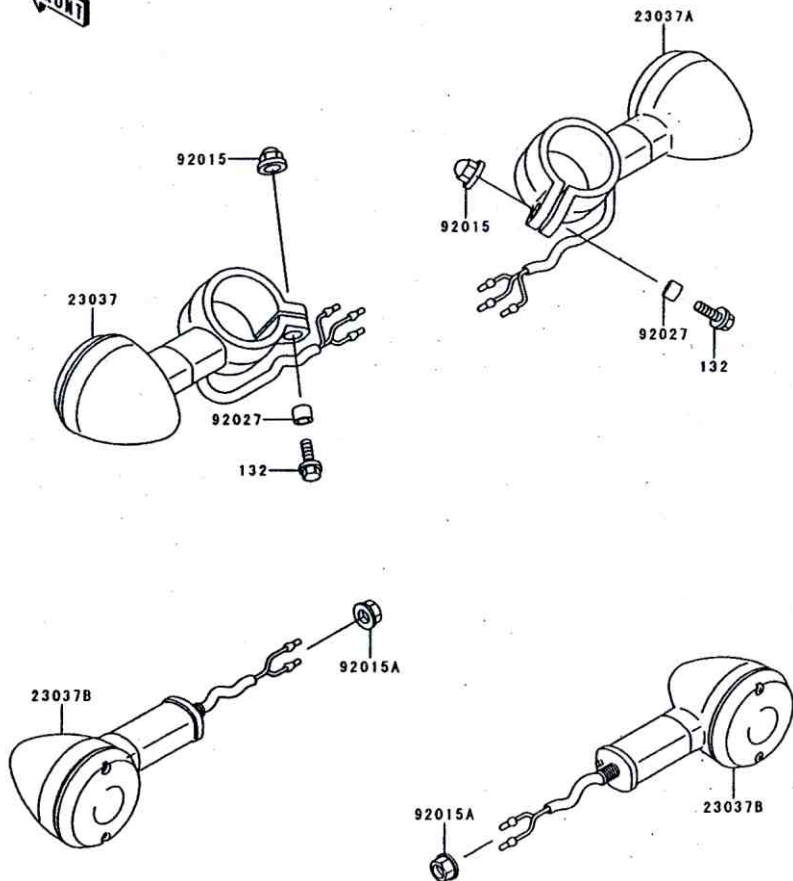

Ref. No.	Part No.	Description	Spec Code	Quantity-BN175			
				'99 A2	'00 A3		
23037	23037-1349	LAMP-ASSY-SIGNAL,FR,LH		1	1		
23037A	23037-1350	LAMP-ASSY-SIGNAL,FR,RH		1	1		
23037B	23037-1351	LAMP-ASSY-SIGNAL,RR		2	2		
92015	92015-1385	NUT,CAP,6MM		2	2		
92015A	92015-1428	NUT,FLANGED,10MM		2	2		
92027	92027-162	COLLAR,6.8X10X12		2	2		
132	132E0620	BOLT-FLANGED-SMALL		2	2		

This catalog covers:

'99~'00 BN175-A2/A3 Chassis

GRID NO.

This grid covers:

F-6

Ignition Switch

F2776

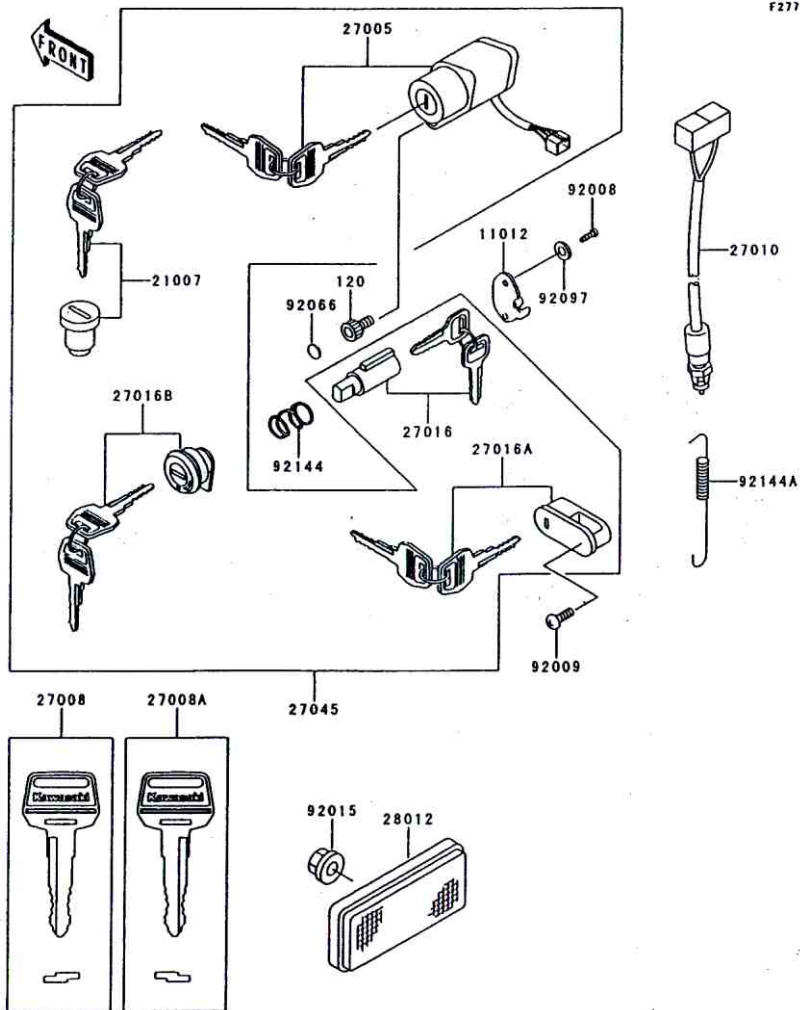

Ref. No.	Part No.	Description	Spec Code	Quantity-BN175		
				'99	'00	
11012	11012-1586	CAP,STEERING LOCK	1	1		
21007	21007-5022	ROTOR,LOCK,TANK CAP	1	1		
27005	27005-1238	SWITCH-ASSY-IGNITION	1	1		
27008	27008-1034	KEY-LOCK,BLANK,#A	1	1		
	(OPTION)					
27008A	27008-1035	KEY-LOCK,BLANK,#B	1	1		
	(OPTION)					
27010	27010-1301	SWITCH,BRAKE LAMP	1	1		
27016	27016-5238	LOCK-ASSY,STEERING	1	1		
27016A	27016-5239	LOCK-ASSY,HELMET	1	1		
27016B	27016-5240	LOCK-ASSY,SIDE COVER	1	1		
27045	27045-5097	SWITCH-ASSY	1	1		
28012	28012-1084	REFLECTOR-REFLEX	1	1		
92008	92008-007	SCREW,3.51MM	1	1		
92009	92009-1341	SCREW,5X14	1	1		
92015	92015-1259	NUT,FLANGED,5MM	1	1		
92066	92066-1435	PLUG	1	1		
92097	92097-003	WASHER,WAVE	1	1		
92144	92144-1222	SPRING,STEERING LOCK	1	1		
92144A	92144-1753	SPRING,REAR BRAKE SWITCH	1	1		
120	120P0512	BOLT-SOCKET	1	1		

This catalog covers:

'99~'00 BN175-A2/A3 Chassis

GRID NO.

F-7

This grid covers:

Owner's Tools

56007

F2810

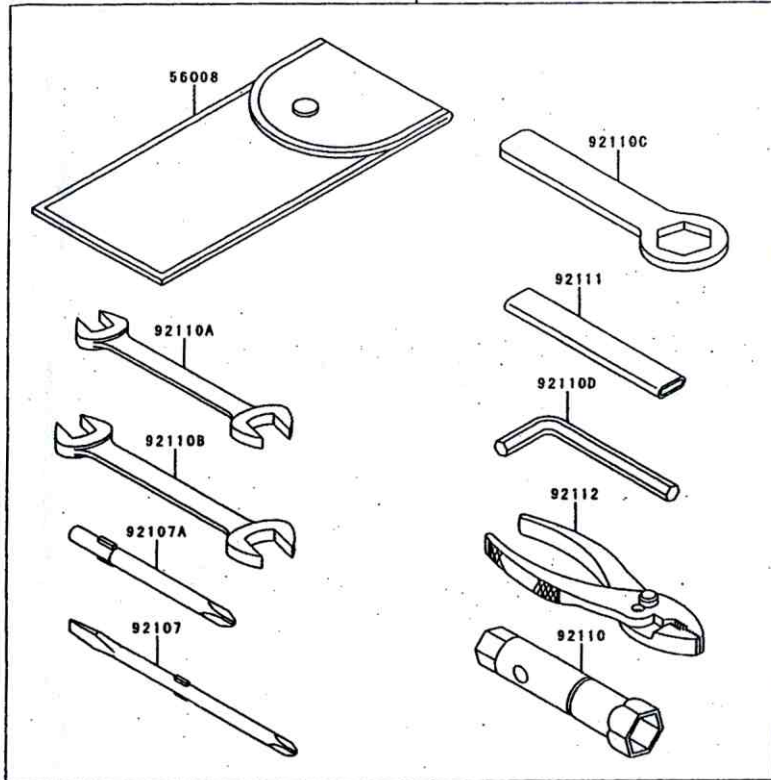

Ref. No.	Part No.	Description	Spec Code	Quantity-BN175			
				'99	'00		
				A2	A3		
56007	56007-1431	TOOL-KIT	1	1			
56008	56008-1085	BAG,TOOL	1	1			
92104	92104-002	GASKET-LIQUID,TUBE,100G,SILVER	1	1			
92107	92107-1060	TOOL-DRIVER,#2PHILLIPS&SLOT	1	1			
92107A	92107-1061	TOOL-DRIVER,#3PHILLIPS	1	1			
92110	92110-1206	TOOL-WRENCH,BOX,16MM	1	1			
92110A	92110-1207	TOOL-WRENCH,OPEN END,10X12	1	1			
92110B	92110-1208	TOOL-WRENCH,OPEN END,14X17	1	1			
92110C	92110-1210	TOOL-WRENCH,BOX END,24MM	1	1			
92110D	92110-1211	TOOL-WRENCH,ALLEN,6MM	1	1			
92111	92111-1058	TOOL-BAR,BOX END WRENCH	1	1			
92112	92112-1056	TOOL-PLIERS	1	1			

This catalog covers:

'99~'00 BN175-A2/A3 Chassis

GRID NO.

F-8

This grid covers:

Labels

F2860

FRONT

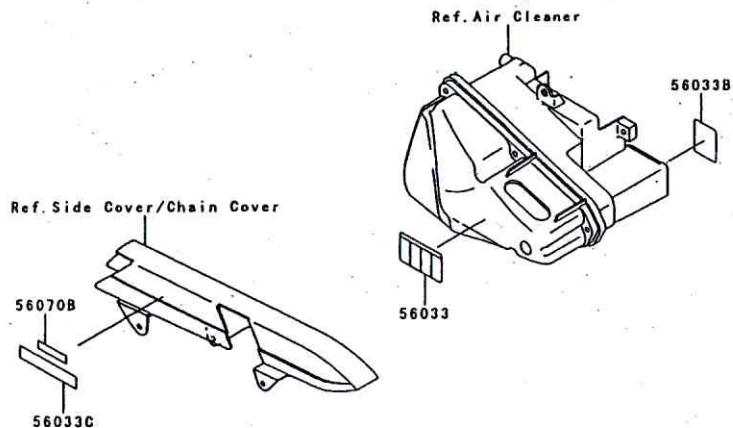
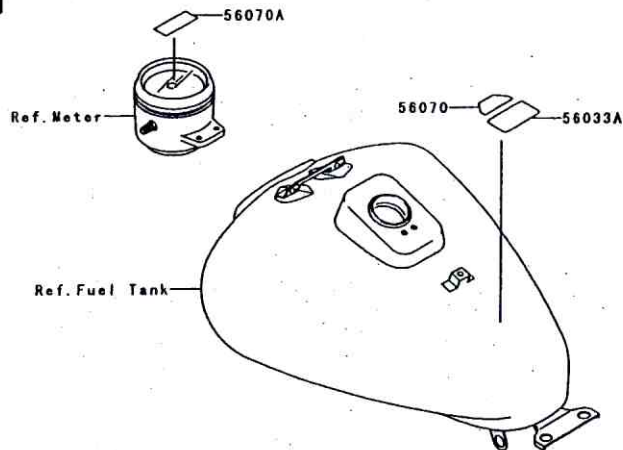

Ref. No.	Part No.	Description	Spec Code	Quantity-BN175			
				'99	'00		
				A2	A3		
56033	56033-1120	LABEL-MANUAL,AIR ELEMENT CLEAN	1	1			
56033A	56033-1121	LABEL-MANUAL,ENGINE START	1	1			
56033B	56033-1140	LABEL-MANUAL,BATTERY VENT	1	1			
56033C	56033-1154	LABEL-MANUAL,CHAIN	1	1			
56070	56070-1156	LABEL-WARNING,FUEL INFO	1	1			
56070A	56070-1157	LABEL-WARNING,SAFETY RIDING	1	1			
56070B	56070-1158	LABEL-WARNING,OIL INFO	1	1			

This catalog covers:

'99~'00 BN175-A2/A3 Chassis

GRID NO. This grid covers:

F-13

Decals(Red)

F20810

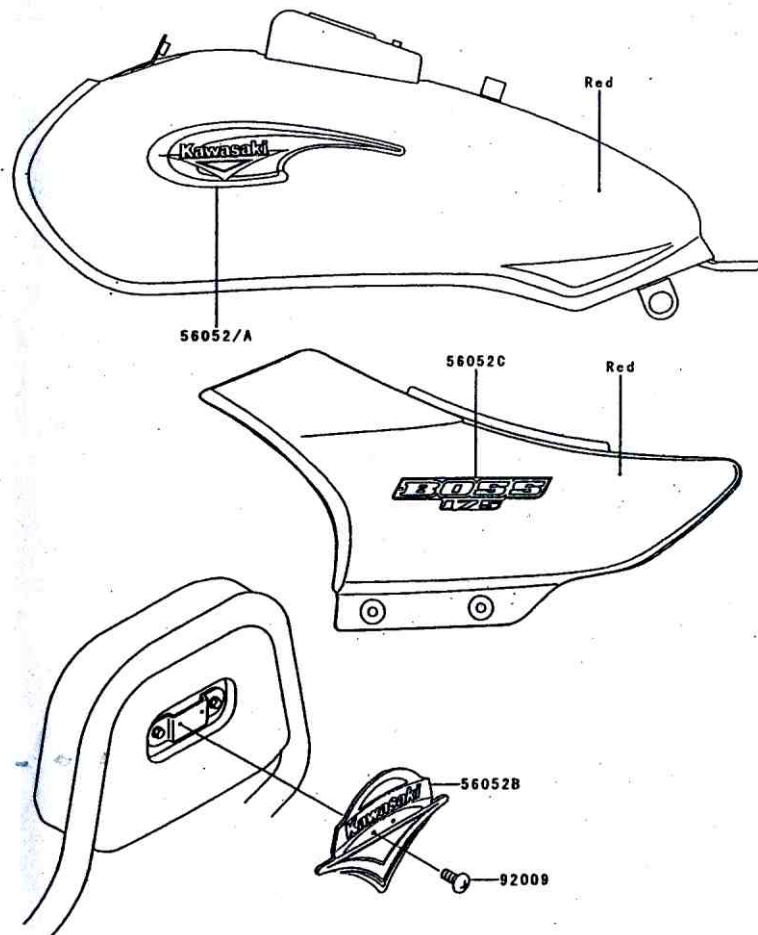

Ref. No.	Part No.	Description	Spec Code	Quantity-BN175		
				'99	'00	
56052	56052-1150	MARK,FUEL TANK,LH			1	
56052A	56052-1151	MARK,FUEL TANK,RH			1	
56052B	56052-1200	MARK,BACK REST			1	
56052C	56052-1242	MARK,SIDE COVER,BOSS 175			2	
92009	92009-1933	SCREW,2X6			2	

This catalog covers:

'99~'00 BN175-A2/A3 Chassis

GRID NO.

F-14

This grid covers:

Decals(Violet)

F2001E

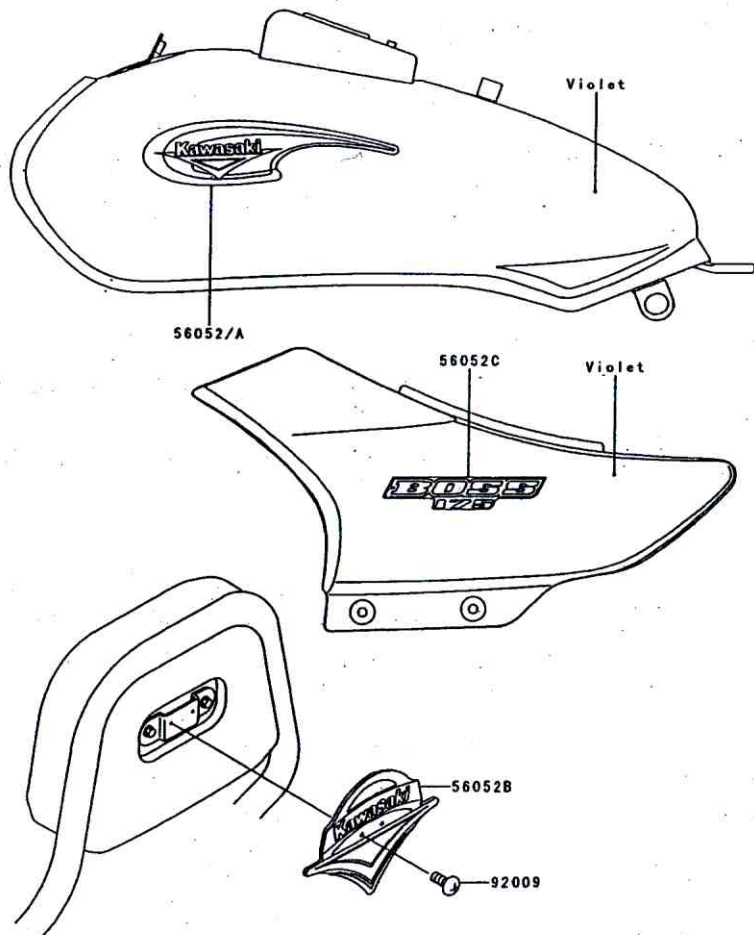

Ref. No.	Part No.	Description	Spec Code	Quantity-BN175			
				'99	'00	A2	A3
56052	56052-1150	MARK,FUEL TANK,LH					1
56052A	56052-1151	MARK,FUEL TANK,RH					1
56052B	56052-1200	MARK,BACK REST					1
56052C	56052-1241	MARK,SIDE COVER,BOSS 175					2
92009	92009-1933	SCREW,2X6					2

This catalog covers:

'99~'00 BN175-A2/A3 Chassis

GRID NO.

G-3

This grid covers:

Decals(Boulogne)

F2861F

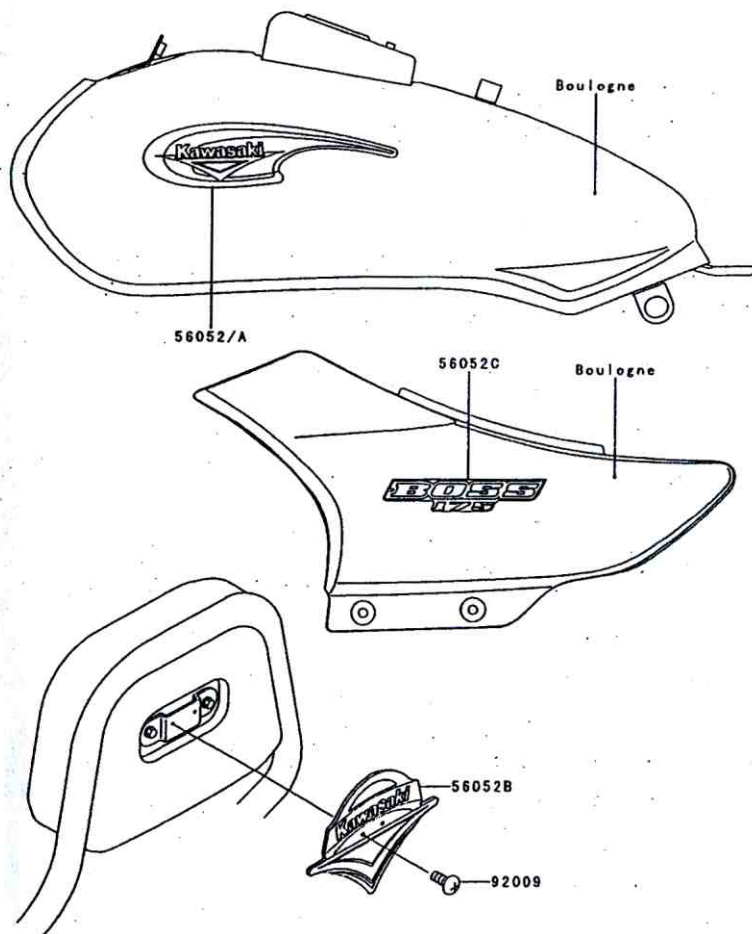

Ref. No.	Part No.	Description	Spec Code	Quantity-BN175			
				'99	'00		
56052	56052-1150	MARK,FUEL TANK,LH					1
56052A	56052-1151	MARK,FUEL TANK,RH					1
56052B	56052-1200	MARK,BACK REST					1
56052C	56052-1240	MARK,SIDE COVER,BOSS 175					2
92009	92009-1933	SCREW,2X6					2

This catalog covers:

'99~'00 BN175-A2/A3 Chassis

GRID NO.

G-4

This grid covers:

Decals(Black)(BN175-A3)

F2881E

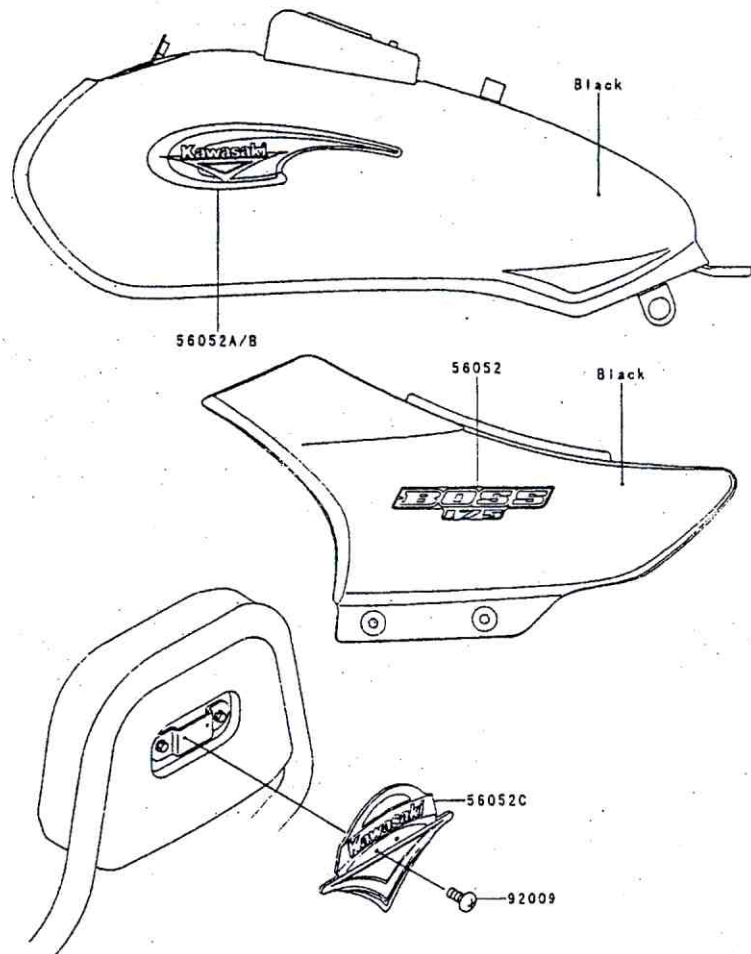

Ref. No.	Part No.	Description	Spec Code	Quantity-BN175			
				'99	'00	A2	A3
56052	56052-1135	MARK.SIDE COVER.BOSS 175					2
56052A	56052-1150	MARK.FUEL TANK.LH					1
56052B	56052-1151	MARK.FUEL TANK.RH					1
56052C	56052-1200	MARK.BACK REST					1
92009	92009-1933	SCREW.2X6					2

NUMERICAL PARTS INDEX

Part No.	Grid No.
11004-1330	B-3
11008-1341	B-3
11009-1105	B-14
11009-1344	B-14
11009-1866	B-6
11010-1678	B-5
11012-1586	F-6
11012-1819	D-5
11012-1821	D-4
11012-1971	C-8
11013-1268	B-5
11050-1383	D-4
11050-1433	E-9
11050-1526	D-4
11050-1741	D-10
11050-1777	C-3
11051-1319	C-6
11051-1679	E-7
11060-1174	F-3
11060-1751	C-3
11060-1752	C-3
11060-1762	B-4
11060-1768	C-8
11060-1808	B-5
11065-1068	D-4
11065-1071	B-3
11065-1088	B-5
11065-1138	C-8
112G0612	D-10
112G0630	E-3
112J0622	E-7
112P0622	D-14
12004-1144	B-7
12005-1294	B-7
12009-1074	B-7
12011-1053	B-7
12016-1115	B-7
12020-1080	B-7
12046-1192	B-8
12048-1169	B-8
12053-1383	B-8
12053-1421	B-8
120P0512	F-6

Part No.	Grid No.
120P0630	C-9
120Q0608	B-11
120S0510	C-11
120S0512	D-7
13001-1506	B-4
13002-1003	B-4
13008-1183	B-4
13024-1114	B-4
13025-1142	B-4
13027-1197	B-4
13029-1253	B-4
13031-1435	B-9
13031-1461	B-9
13032-1268	B-9
13034-1105	B-9
13037-1578	B-9
13038-1084	B-9
13041-1129	B-9
13042-1126	E-7
13087-1169	B-10
13088-1085	B-10
13088-1098	B-10
13089-1076	B-10
13091-1272	E-7
13091-1884	C-11
13095-1388	B-10
13097-1378	B-9
130J0610	E-10
130J0612	B-14
130J0612	D-4
130J0612	D-10
130J0612	E-9
130J0612	F-5
130J0614	E-12
130J0616	D-4
130J0620	E-9
130J0622	B-6
130J0812	D-10
130J0820	D-4
130S0612	B-8
130V0620	E-14
13102-1139	B-10
13127-1263	B-11

Part No.	Grid No.
13128-1225	B-11
13129-1555	B-11
13139-1080	B-11
13140-1278	B-12
13140-1279	B-12
13140-1280	B-12
13141-1210	B-12
13144-1144	B-11
13145-1084	B-12
13151-1080	B-12
13161-1234	B-13
13165-1154	B-13
13169-1691	B-14
13183-1066	B-12
13187-1072	B-10
13194-1107	C-11
13216-1167	C-8
13236-1192	B-12
13236-1334	B-13
13242-1290	B-13
13260-1704	B-11
13260-1772	B-11
13260-1773	B-11
13260-1774	B-11
13260-1775	B-11
13260-1776	B-11
13260-1777	B-11
13270-1484	E-10
13270-1665	C-3
13270-1855	C-3
13270-1910	B-3
13271-1052	B-11
13271-1056	C-3
13271-1057	C-3
13271-1103	B-5
13271-1109	B-3
13271-1344	C-3
13271-1534	E-7
13280-1095	C-6
13280-1121	B-9
132E0610	D-7
132E0614	E-10
132E0616	E-7

Part No.	Grid No.
132E0616	E-11
132E0620	E-8
132E0620	F-4
132E0820	D-10
132E0830	D-10
132E0830	E-7
132G0612	C-3
132J0610	D-7
132J0625	C-9
132J0820	D-7
132J0830	D-7
132V0614	B-3
132V0616	C-8
132V0618	B-3
132V0620	C-8
132V0625	B-3
132V0625	B-7
132V0625	B-8
132V0625	C-11
132V0635	C-3
132V0650	C-3
132V0655	C-3
132V0660	B-14
132V0665	C-3
132V0670	C-3
132Y0612	B-3
132Y0612	B-14
132Y0614	B-8
132Y0630	B-8
14001-1271	B-14
14001-1272	B-14
14014-1057	B-14
14014-1095	B-8
14014-1113	B-14
14014-1129	C-3
14026-1256	B-3
14026-1265	C-3
14031-1368	C-3
14032-1497	C-3
14069-1064	B-5
14073-1725	B-5
14073-1734	B-5
14090-1836	D-10

Part No.	Grid No.
14090-1837	D-10
14090-1856	D-10
14090-1863	E-11
14090-1937	D-7
14090-1977	B-5
14091-1113	B-5
14091-1123	F-5
14091-1125	C-6
15003-1607	C-6
16005-1086	C-6
16007-1159	B-7
16007-1162	B-10
16014-1103	C-6
16016-1110	C-6
16017-1401	C-6
16030-1093	C-6
16031-1101	C-6
16032-003	C-6
16038-016	C-6
16060-1081	B-3
16065-1356	B-3
16082-1153	C-8
16085-1309	C-11
16126-1371	C-6
16130-1001	C-3
16146-1190	E-9
16154-1077	C-8
16187-1093	C-6
172G0612	B-12
18069-1014	B-6
18087-1078	B-6
180J0616	E-3
187B0620	C-10
21003-1342	C-9
21007-1346	C-9
21007-5022	F-6
21017-017	C-11
21025-011	C-11
21039-1066	C-11
21040-1057	C-11
21066-1108	C-9
21119-1560	C-10
21121-1229	C-10

NUMERICAL PARTS INDEX

Part No.	Grid No.
21131-005	C-10
21160-1062	C-10
21163-1290	C-11
220B0308	E-9
220B0610	C-8
220B0614	B-14
220B0620	C-8
220B0630	C-8
220C0525	E-7
220C0530	E-7
220C0540	E-7
220D0410	C-7
220D0510	E-9
220D0512	E-14
220E0408	E-11
221B0408	C-7
221B0414	E-9
221B0612	B-14
221C0316	E-7
223B0408	C-7
223B0414	C-7
223B0514	C-9
23005-1183	E-14
23006-1082	E-14
23007-1386	E-14
23008-1606	E-11
23016-1175	E-11
23020-018	E-14
23021-010	E-14
23025-1275	F-3
23026-1212	E-11
23026-1213	E-11
23026-1214	E-11
23026-1234	F-3
23037-1349	F-4
23037-1350	F-4
23037-1351	F-4
236D0616	C-10
25005-1655	E-11
26004-1113	F-5
26006-1003	F-5
26011-1670	F-5
26011-1674	F-5

Part No.	Grid No.
26011-1682	C-11
26012-1367	F-5
26030-1653	F-5
26030-1749	F-5
27002-1086	F-5
27002-1107	F-5
27003-1411	F-5
27005-1238	F-6
27008-1034	F-6
27008-1035	F-6
27010-1094	E-7
27010-1170	E-4
27010-1301	F-6
27010-1327	C-11
27016-5238	F-6
27016-5239	F-6
27016-5240	F-6
27045-5097	F-6
28012-1084	F-6
290Q0606	B-3
311G0600	B-12
312C0600	F-5
318C0800	D-5
32109-1263	D-10
32109-1275	D-10
32109-1277	D-10
32109-1294	D-10
32109-1295	D-10
32160-1590	D-3
32190-1092	D-4
32190-1093	D-4
32190-1104	D-4
32190-1109	D-4
33001-1599	D-5
33032-1109	D-5
33040-1178	D-5
34003-1465	D-7
34003-1486	D-7
34003-1490	D-7
34024-1353	D-11
34028-1372	D-7
34028-1373	D-7
34028-1495	D-7

Part No.	Grid No.
34028-1496	D-7
35001-1192-8W	D-10
35001-1192-R8	D-10
35001-1192-US	D-10
35001-1192-Y5	D-10
35011-1860	D-10
35019-1358	D-10
35023-1496-JB	D-10
35023-1496-TS	D-10
35023-1496-UR	D-10
35023-1496-UT	D-10
36001-1606-JB	E-13
36001-1606-R8	E-13
36001-1606-US	E-13
36001-1606-Y5	E-13
36001-1607	E-13
36001-1610-8W	E-13
36001-1610-R8	E-13
36001-1610-US	E-13
36001-1610-Y5	E-13
36014-1228	E-13
39076-1060	C-11
39110-1124	B-13
39156-1581	D-10
39193-1025	B-14
41022-1168	D-12
41022-1206	D-12
41023-1126	D-12
41023-1127	D-12
41025-1351	D-12
41025-1405	D-12
41029-1280	D-12
41029-1281	D-12
41030-1154	D-12
41030-1155	D-12
41032-1080	D-12
41034-1312	D-13
41034-1318	D-14
41035-1504	D-14
41048-1025	D-14
41050-1096	D-14
41053-1087	D-14
41060-1133	D-13

Part No.	Grid No.
41060-1134	D-13
41068-1392	D-14
41068-1421	D-13
41070-1315-NR67/18	D-12
41070-9017-NF53/18	D-12
41078-1087	D-13
41080-1451	E-5
41085-013	D-14
410F0600	E-7
410F0800	D-5
411F0600	D-7
42014-030	D-14
42033-1202	D-14
42036-030	D-14
42036-1338	D-5
42041-1518	D-14
43001-1404	E-3
43007-1037	E-3
43012-001	E-12
43015-1664	E-4
43020-1095	E-4
43022-1010	E-4
43026-1074	E-4
43028-1061	E-4
43028-1088	C-6
43028-1089	C-6
43034-1016	E-4
43041-1695	E-5
43045-1010	E-5
43048-1068	E-5
43049-1060	E-5
43049-1061	E-5
43049-1066	E-9
43056-1056	E-5
43057-1001	E-5
43058-1094	C-6
43064-007	E-8
43067-001	E-4
43082-1238	E-5
43092-1203	E-4
43095-1136	E-4
44005-1391	E-8
44006-1390	E-8

Part No.	Grid No.
44013-1444	E-8
44023-1128	E-8
44026-1680	E-8
44029-1136	E-8
44033-1226	E-8
44037-1361	E-8
44039-1286	E-8
44043-057	E-8
44045-051	E-8
44065-1123	E-8
44065-1124	E-8
44075-1076	E-8
45014-1685	D-6
45016-008	D-6
45017-012	D-6
45017-015	D-6
46003-1543	E-7
46012-1321	E-7
46012-1322	E-7
46012-1323	E-7
46019-1107	E-7
46075-1080	E-7
46076-1222	E-7
46091-1768	E-7
46091-1771	E-7
46092-1206	E-7
46098-016	D-3
46102-1402	B-10
461F0500	E-14
461K0500	C-11
46F1000	E-7
480J4000	B-9
482J6000	C-8
482L0100	D-7
49002-1138	B-3
49006-1088	E-5
49006-1242	E-5
49016-1044	E-4
49016-1129	E-14
49047-1068	B-12
49065-1075	C-8
49078-1189	B-7
49118-1199	B-8

NUMERICAL PARTS INDEX

Part No.	Grid No.
49123-1053	C-6
51001-1593-8W	E-9
51001-1593-R8	E-9
51001-1593-US	E-9
51001-1593-Y5	E-9
51023-1236	E-9
51044-1196	B-5
51049-1088	E-9
51081-5223-G4	E-9
51081-5224-J8	E-9
510A3200	B-12
510A5100	B-9
52005-1009	C-3
52010-1053	C-8
53001-1905-MA	E-10
53004-1123	F-5
53044-1316	E-9
54001-1237	E-12
54001-1245	E-12
54005-1208	E-12
54011-1405	E-12
54012-1627	E-12
54012-1628	E-12
55020-1682	D-7
55020-1687	E-12
55020-1689	D-5
550D2018	D-7
550D2018	E-12
550D3025	D-13
550D4035	D-14
551A0306	B-12
554A0800	E-3
56001-1523	E-7
56001-1524	E-7
56007-1431	F-7
56008-1085	F-7
56033-1120	F-8
56033-1121	F-8
56033-1140	F-8
56033-1154	F-8
56052-1135	G-4
56052-1150	F-13
56052-1150	F-14

Part No.	Grid No.
56052-1150	G-3
56052-1150	G-4
56052-1151	F-13
56052-1151	F-14
56052-1151	G-3
56052-1151	G-4
56052-1200	F-13
56052-1200	F-14
56052-1200	G-3
56052-1200	G-4
56052-1240	G-3
56052-1241	F-14
56052-1242	F-13
56070-1156	F-8
56070-1157	F-8
56070-1158	F-8
59006-1057	B-5
59051-1324	B-9
59051-1325	B-9
600A0800	D-3
601A6202Z	B-14
601A6204	B-14
601A6304Z	B-14
601B6003	B-12
601B6004UU	D-14
601B6202G	D-13
601B6202UU	D-14
601B6302UU	D-14
670B1504	E-9
670B1508	C-3
670B1510	B-3
670B1510	C-8
670D2010	B-8
671B2595	B-3
92001-1041	E-5
92001-1178	D-10
92001-1464	E-8
92001-1488	D-3
92001-1524	E-9
92001-1548	E-7
92001-1616	D-4
92001-1641	D-4
92001-1719	D-4

Part No.	Grid No.
92001-1728	E-4
92001-1729	E-4
92001-1780	D-4
92002-1237	B-13
92002-1323	E-4
92002-1571	E-10
92002-1618	B-14
92002-1796	C-11
92002-1826	B-6
92002-1888	E-4
92002-1944	C-3
92002-1975	B-14
92004-1121	B-3
92005-1247	B-5
92005-1337	B-3
92005-1342	B-3
92008-007	F-6
92009-1134	E-7
92009-1172	E-11
92009-1197	E-13
92009-1266	B-14
92009-1287	E-13
92009-1288	E-13
92009-1341	F-6
92009-1360	B-12
92009-1378	F-3
92009-1458	E-4
92009-1472	E-14
92009-1484	E-7
92009-1621	B-5
92009-1621	D-4
92009-1830	B-5
92009-1831	B-5
92009-1850	C-6
92009-1853	C-6
92009-1891	C-6
92009-1933	F-13
92009-1933	F-14
92009-1933	G-3
92009-1933	G-4
92009-1947	E-14
92013-009	B-7
92015-042	E-12

Part No.	Grid No.
92015-072	B-10
92015-1157	E-14
92015-1180	D-4
92015-1188	D-11
92015-1191	E-7
92015-1197	E-7
92015-1233	E-4
92015-1251	D-4
92015-1259	F-6
92015-1367	F-3
92015-1367	E-14
92015-1370	B-13
92015-1371	B-6
92015-1385	E-8
92015-1385	F-4
92015-1387	B-6
92015-1391	E-3
92015-1407	D-5
92015-1428	E-3
92015-1428	F-4
92015-1465	B-9
92015-1476	C-11
92015-1668	D-14
92015-1765	D-13
92015-1959	D-5
92016-061	B-7
92020-003	D-6
92022-044	D-6
92022-072	B-10
92022-077	B-3
92022-077	B-7
92022-1033	B-11
92022-1123	C-6
92022-1132	C-11
92022-1181	C-8
92022-1187	C-6
92022-1232	B-9
92022-1346	E-3
92022-1356	B-10
92022-1373	E-5
92022-1510	D-13
92022-1511	D-13
92022-1540	D-6

Part No.	Grid No.
92022-1557	E-10
92022-1557	F-3
92022-1568	D-7
92022-1582	E-12
92022-1588	E-12
92022-1654	E-13
92022-1792	B-12
92022-1822	E-11
92022-1827	B-12
92022-183	E-9
92022-1977	E-9
92022-212	C-11
92022-231	E-8
92022-252	B-11
92022-289	B-6
92026-1217	B-12
92026-1235	B-9
92026-1365	E-8
92027-1142	B-6
92027-162	F-3
92027-162	F-4
92027-1757	B-5
92027-1866	D-13
92027-251	E-9
92027-252	E-14
92033-1160	D-13
92033-1161	B-4
92033-1247	B-3
92033-1260	B-11
92033-1299	C-6
92033-1313	B-11
92037-1069	E-12
92037-1069	F-5
92037-1163	D-10
92037-1163	F-5
92037-1610	C-6
92037-1712	E-9
92037-1794	E-9
92037-192	B-5
92038-001	B-9
92038-3703	B-9
92043-065	E-12
92043-1013	E-12

NUMERICAL PARTS INDEX

Part No.	Grid No.
92043-1144	D-7
92043-1220	D-13
92043-1263	B-14
92043-1263	C-8
92043-1416	E-5
92043-1581	D-7
92043-4009	B-3
92043-4009	B-4
92045-1041	B-14
92045-1169	B-14
92045-1367	B-14
92046-1010	C-3
92046-1174	D-5
92047-011	D-3
92047-012	E-8
92048-006	D-3
92048-008	D-3
92049-1173	D-13
92049-1191	C-3
92049-1271	C-3
92049-1289	D-5
92049-1340	E-8
92049-1348	D-13
92049-1349	B-7
92049-1398	B-13
92049-1487	D-14
92050-013	B-14
92051-005	B-14
92055-004	D-14
92055-022	B-11
92055-1023	E-9
92055-1078	C-6
92055-1093	C-6
92055-1112	E-9
92055-112	B-3
92055-1146	C-3
92055-1242	C-6
92055-1256	B-3
92055-1276	C-11
92055-1325	B-3
92055-1367	E-8
92055-1370	C-11
92055-1419	E-9

Part No.	Grid No.
92055-1550	C-11
92055-1551	C-11
92055-1577	C-8
92056-003	E-8
92057-1299	D-14
92057-1457	B-8
92058-1058	D-14
92062-1053	B-9
92063-1433	C-6
92063-1434	C-6
92063-1447	C-6
92063-2234	C-6
92064-1195	C-6
92064-1199	C-6
92065-058	B-12
92065-097	B-14
92066-1012	B-14
92066-1174	B-14
92066-1249	B-9
92066-1301	E-9
92066-1355	B-14
92066-1435	F-6
92066-1478	B-3
92066-1482	C-3
92069-063	F-3
92069-1002	E-14
92069-1007	E-11
92069-1059	E-11
92070-1168	C-10
92071-056	F-5
92071-1043	E-13
92071-1043	F-5
92071-1124	C-10
92072-030	F-5
92072-1195	F-5
92072-1197	F-5
92072-1348	D-4
92072-1373	E-10
92075-035	E-9
92075-101	E-9
92075-1089	B-3
92075-1967	E-13
92075-209	E-9

Part No.	Grid No.
92076-020	D-7
92077-1124	E-11
92081-1492	B-10
92081-1550	D-14
92081-1766	D-14
92081-1829	B-13
92087-1051	D-13
92090-007	D-3
92092-1013	B-6
92093-1280	E-8
92097-003	F-6
92103-006	D-14
92104-002	F-7
92107-1060	F-7
92107-1061	F-7
92110-1206	F-7
92110-1207	F-7
92110-1208	F-7
92110-1210	F-7
92110-1211	F-7
92111-1058	F-7
92112-1056	F-7
92143-1014	D-14
92143-1311	E-8
92143-1353	B-6
92143-1683	E-8
92143-1857	B-8
92143-1869	B-11
92143-1949	D-13
92143-1950	D-14
92143-1951	D-14
92144-1008	D-11
92144-1074	B-13
92144-1149	E-14
92144-1222	F-6
92144-1522	B-10
92144-1557	E-5
92144-1567	D-7
92144-1568	D-7
92144-1674	C-6
92144-1753	F-6
92144-1761	C-8
92144-1995	B-10

Part No.	Grid No.
92145-1072	E-3
92145-1195	B-9
92145-1196	B-9
92145-1235	B-10
92145-1244	C-6
92145-1245	C-6
92145-1246	C-6
92145-1374	C-7
92150-1133	D-10
92150-1153	D-7
92150-1297	D-6
92150-1340	E-8
92150-1381	B-8
92150-1387	E-8
92150-1394	B-3
92150-1715	B-10
92150-1858	E-5
92150-1908	B-13
92150-1969	C-11
92150-1975	D-11
92150-1986	B-3
92151-1092	B-3
92151-1203	E-3
92151-1248	E-9
92151-1261	E-8
92151-1262	E-8
92151-1268	B-3
92151-1320	D-14
92151-1337	E-3
92151-1362	B-13
92151-1422	D-7
92160-1068	E-11
92160-1162	F-3
92160-1167	E-8
92160-1380	E-11
92160-1423	B-14
92160-1637	B-13
92160-1762	C-3
92160-1847	D-10
92160-1855	C-3
92160-1864	D-10
92160-1891	E-13
92160-1893	D-10

Part No.	Grid No.
92160-1895	B-6
92160-1923	C-3
92160-1957	E-7
92170-1017	B-5
92170-1387	B-3
92170-1527	B-3
92170-1624	E-14
92170-1769	E-8
92170-1796	B-5
92170-1818	C-7
92170-1833	C-3
92170-1840	E-8
92170-1841	E-8
92170-1845	B-5
92170-1864	B-5
92170-1892	E-8
92170-1936	C-7
92170-1948	E-8
92171-1054	C-7
92171-1063	E-12
92181-1993	B-12
92190-1103	D-4
92191-1162	B-5
92191-1208	B-5
92191-1210	C-7
92191-1217	E-14
92191-1241	B-5
92191-1302	E-9
92191-1349	C-7
92191-1350	C-7
92200-1037	B-3
92200-1314	B-9
92200-1366	D-13
92200-1366	D-14
92200-1439	E-9
92200-1440	B-10
92200-1468	C-7
92200-3717	B-13
92210-1080	E-7
92210-1163	B-9
98111-1073	B-4

This catalog covers:

'99~00' BN 175-A2/A3

This grid covers:

Part Name Index

Air Cleaner.....	B-5
Brake Pedal.....	E-3
Cables.....	E-12
Camshaft(s).....	B-8
Carburetor (BN 175-A3).....	C-6/C-7
Chain Cover.....	E-13
Chassis Electrical Equipment.....	F-5
Clutch.....	B-10
Crankcase.....	B-14
Crankshaft.....	B-9
Cylinder.....	B-4
Cylinder Head.....	B-3
Decals (Boulogne).....	G-3
Decals (Black).....	G-4
Decals (Red).....	F-13
Decals (Violet).....	F-14
Engine Cover(s).....	C-3
Fenders (BN 175-A3).....	D-10
Footrests.....	D-7
Frame.....	D-3
Frame Fittings.....	D-4
Front Brake.....	E-5
Front Fork.....	E-8
Front Hub.....	D-13
Front Master Cylinder.....	E-4
Fuel Tank.....	E-9
Gear Change Drum.....	B-12

Generator.....	C-9
Handlebar (BN 175-A3).....	E-7
Headlight(s).....	E-14
Ignition Switch.....	F-6
Ignition System.....	C-10
Labels.....	F-8
Meter(s).....	E-11
Muffler(s).....	B-6
Oil Pump.....	C-8
Owner's Tools.....	F-7
Piston(s).....	B-4
Rear Hub.....	D-14
Seat.....	E-10
Shift Fork(s).....	B-12
Shock Absorber.....	D-6
Side Covers.....	E-13
Stand(s).....	D-11
Starter Motor.....	C-11
Suspension.....	D-6
Swingarm.....	D-5
Taillight(s).....	F-3
Tensioner.....	B-8
Tires.....	D-12
Transmission.....	B-11
Turn Signals.....	F-4
Valve(s).....	B-7