



AN80-G2

Joy

Catálogo de Partes



AN80-G2
For Colombia Market

Motorcycle
Parts Catalog

'96 AN80-G2 (CL) 99917-5247-05

PREFACIO

Es nuestro placer presentarles a ustedes el Catálogo de Partes.

Este Catálogo ha sido especialmente diseñado para ayudarle en la selección de las partes correctas con el fin de mantener el vehículo en las mejores condiciones.

Los repuestos originales están sujetos a un exigente estándar de control de calidad, por lo tanto es necesario que usted sólo use repuestos originales.

En nuestro constante esfuerzo para mejorar la eficiencia y desempeño de su vehículo, las especificaciones, diagramas y número de partes pueden cambiar sin previo aviso. Consecuentemente las descripciones de los repuestos en este Catálogo pueden no ser las finales y definitivas.

Las alteraciones y modificaciones que ocurran en la impresión de este catálogo, serán informadas a nuestra red, a través de circulares de Servicio. Es requisito que usted actualice su Catálogo y haga las correcciones necesarias, una vez reciba dichas circulares. Lo anterior le asegurará un rápido y adecuado despacho de sus partes, pues las órdenes están siendo diligenciadas con las referencias más actualizadas.

En caso de necesitar asistencia técnica, comunicarse con el Distribuidor Autorizado o llamar al Departamento de Servicios Auteco-Kawasaki.

INDEX

51

MAIN TITLE	PAGE
CYLINDER HEAD	1
CYLINDER/PISTON	2
AIR FILTER	3
MUFFLER	4
VALVE	5
CAMSHAFT/TENSIONER	6
CRANKSHAFT	7
KICKSTARTER MECHANISM	8
CLUTCH	9
TRANSMISSION	10
CHANGE DRUM/SHIFT FORK	11
GEAR CHANGE MECHANISM	12
CRANKCASE	13
ENGINE COVER	14
CARBURETTOR (1/2)	15
CARBURETTOR (2/2)	15A
CARBURETTOR MIKUNI (1/2)	16
CARBURETTOR MIKUNI (2/2)	16A
OIL PUMP	17
GENERATOR	18
IGNITION COIL	19
STARTER MOTOR	20
FRAME	21

MAIN TITLE	PAGE
FRAME FITTING	22
SWING ARM / SHOCK ABSORBER	23
STEP	24
FENDER	25
STAND	26
TIRE	27
FRONT HUB	28
REAR HUB	29
BRAKE PEDAL	30
HANDLEBAR	31
FRONT FORK	32
FUEL TANK	33
SEAT	34
METER	35
CABLE	36
SIDE COVER /CHAIN CASE	37
LEG SHIELD	38
HEAD LAMP	39
TAIL LAMP	40
TURN SIGNAL	41
ELECTRICAL EQUIPMENT	42
IGNITION SWITCH	43
TOOL	44
LABEL	45

This catalog covers:
'96 AN80-G2 Engine

GRID NO.

B-3

This grid covers:
Cylinder Head

E1111-0140

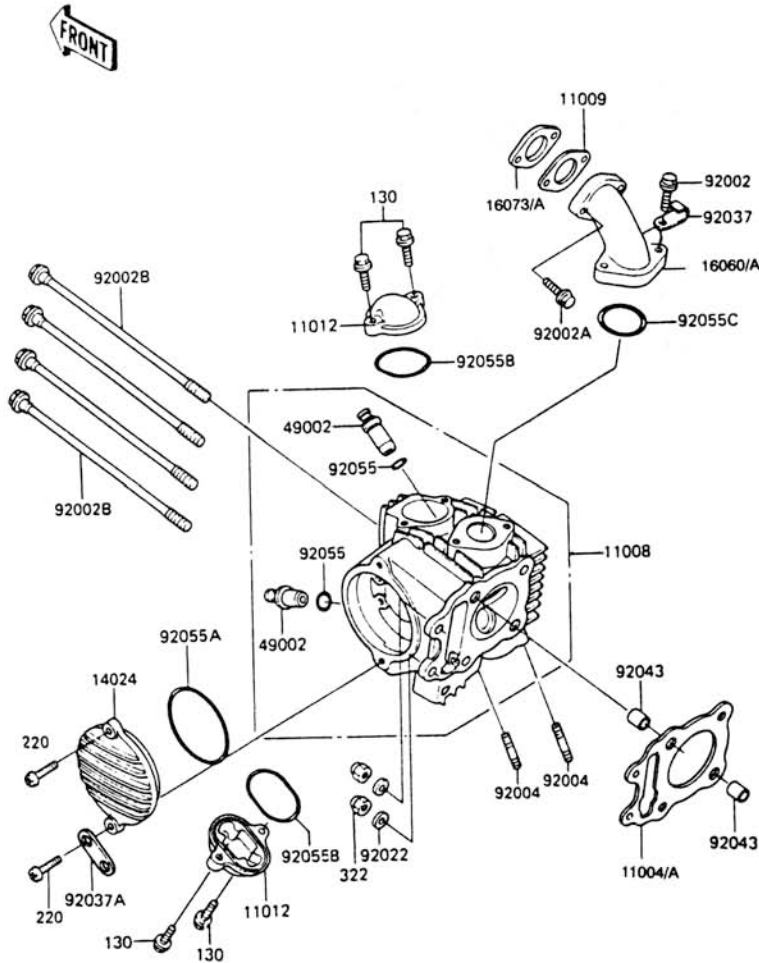

Ref. No.	Part No.	Description	Spec Code	Quantity - AN80			
				96			
				G2			
11004	11004-1293	GASKET - HEAD		1			
11008	11008-1078	HEAD-COM-CYLINDER		1			
11009	11009-1347	GASKET INTAKE PIPE		1			
11012	11012-1303	CAP VALVE ADJUSTING		2			
14024	14025-1692	COVER CAMSHAFT SPROCK		1			
16060	16060-1065	PIPE INTAKE		1			
16073	16073-1060	INSULATOR		1			
49002	49002-1056	GUIDE VALVE		2			
92002	92002-1235	BOLT 6 X 25		2			
89002A	92001-1352	BOLT FLANGED 6X22		2			
92002B	92002-1369	BLT BX177		4			
92004	92004-1127	STUD 6X18		2			
92022	92022-1506	WASHER 6.5 X 11		2			
92037	92037-1069	CLAMP WIRING HERNESS		1			
92037A	92037-1575	CLAMP		1			
92043	92043-1264	PIN 8.2X10X14		2			
92055	92055-1177	RING-O VALVE GUIDE		2			
92055A	92055-1178	RING-O 68.6 MM		1			
92055B	92055-1231	RING-O ADJUST CAP		2			
92055C	92055-1257	RING-O, 30MM		1			
130	130Y0620	BOLT-FLANGED		4			
220	220X0620	SCREW-PAN-CROS		2			
322	322B0600	NUT-CAP 6MM		2			

E1120-0053

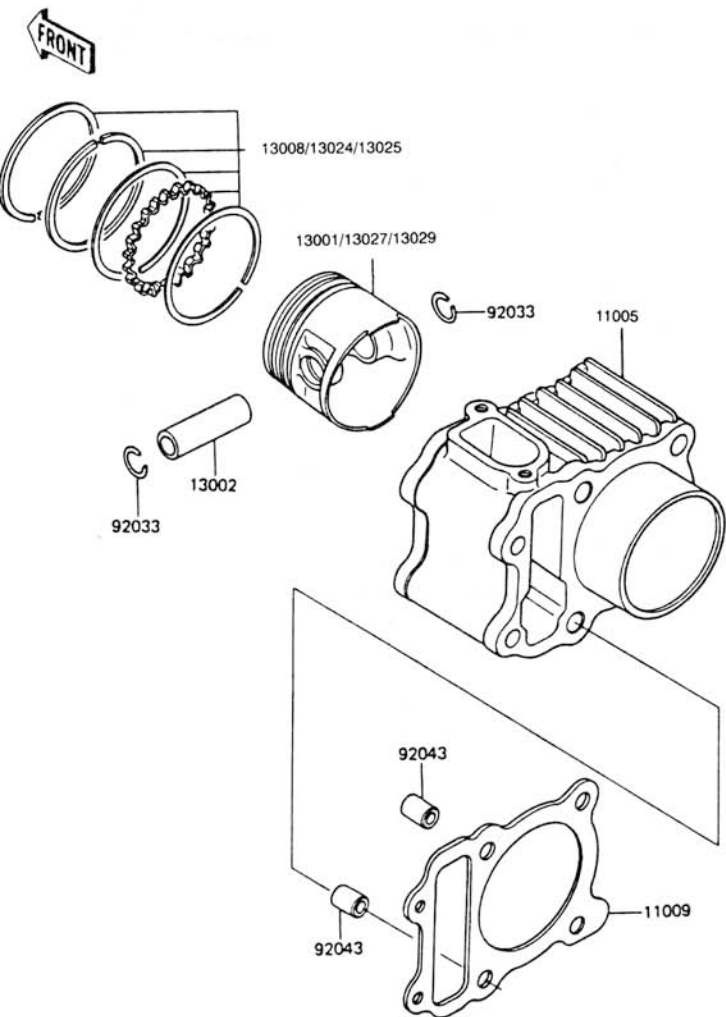

Ref. No.	Part No.	Description	Spec Code	Quantity - AN80			
				96			
11005	11005-1593	CYLINDER-ENGINE		1			
11009	11060-1506	GASKET, CYLINDER BASE		1			
13001	13001-1084	PISTON-ENGINE		1			
13002	13002-1061	PIN-PISTON		1			
13008	13008-1062	RING-SET-PISTON, STD		1			
13024	13024-1016	RING-SET-PISTON LL,0/S 1.00		1			
13025	13025-1016	RING-SET-PISTON L, 0/S 0,50		1			
13027	13027-1037	PISTON ENGINE LL,0/S 100		1			
13029	13029-1038	PISTON-ENGINE L.0/S 0,50		1			
92033	92033-1072	RING-SNAP		2			
92043	92043-1264	PIN 8,2X10X14		2			

This catalog covers:
 '96 AN80-G2 Engine

GRID NO.

B-5

This grid covers:
Air Filter

E1130-0141

FRONT

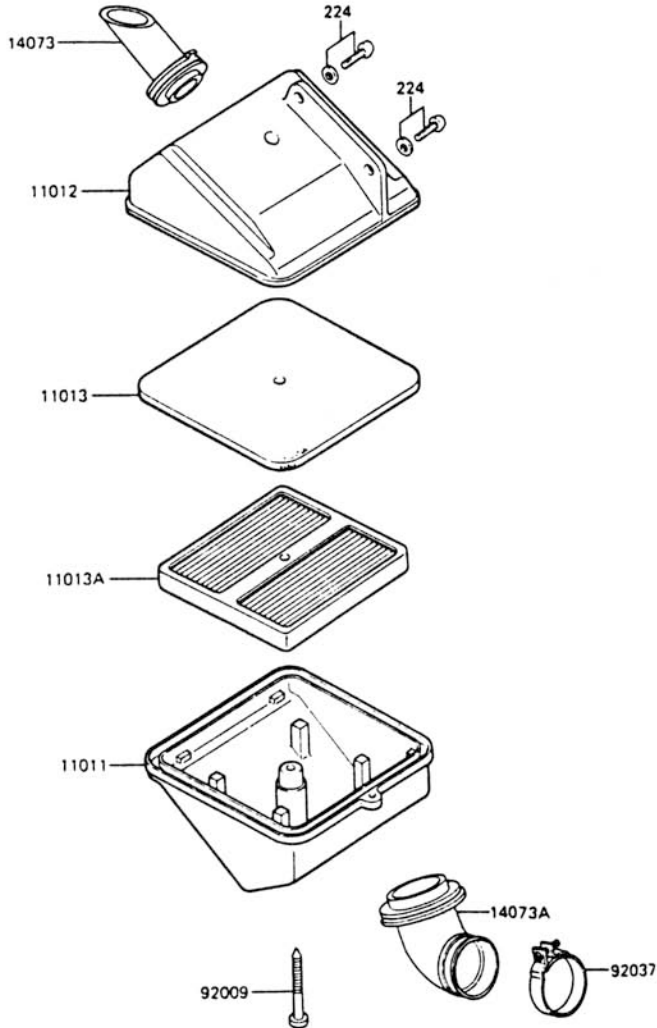

Ref. No.	Part No.	Description	Spec Code	Quantity - AN80			
				96			
11011	11011-1072	CASE-AIR FILTER		1			
11012	11012-1157	CAP, AIR FILTER		1			
11013	11013-1044	ELEMENT-AIR FILTER		1			
11013A	11013-1046	ELEMENT-AIR FILTER		1			
14073	14073-1157	DUCT, AIR FILTER, IN		1			
14073A	14073-1163	DUCT, AIR FILTER, OUT		1			
92009	92009-1124	SCREW, 6x45		1			
92037	92037-1407	CLAMP, 39MM		1			
224	224B0614	SCREW-PAN-WP-CROS		2			

This catalog covers:
'96 AN80-G2 Engine

GRID NO.
B-6

This grid covers:
Muffler

E1140-0185

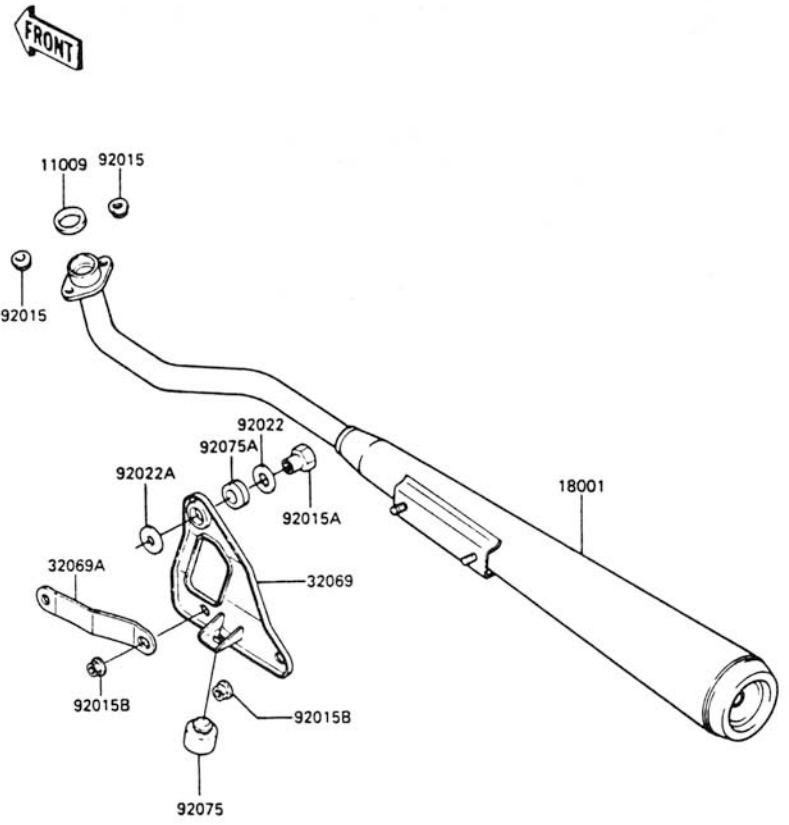

Ref. No.	Part. No.	Description	Spec Code	Quantity - AN80			
				96			
				G2			
11009	11060-1488	GASKET EXHAUST PIPE		1			
18001	18001-1537	MUFFLER		1			
32069	32069-1215	BRACKET-MUFFLER		1			
	32069-1215/00	BRACKET-MUFFLER		1			Opcional
32069A	32069-1224	BRACKET-MUFFLER		1			
	32069-1224/00	BRACKET-MUFFLER		1			Opcional
92015	92015-1365	NUT 6MM		2			
92015A	92015-1396	NUT 10MM		1			
92015B	92015-1409	NUT FLANGED 8MM		2			
92022	92022-1550	WASHER 15.5X28X2		1			
92022A	92022-1551	WASHER 10X28X2		1			
92075	92075-015	DAMPER		1			
92075A	92075-1621	DAMPER MUFFLER		1			

This catalog covers:
 '96 AN80-G2 Engine

GRID NO.

B-7

This grid covers:
 Valve

E1210-0023



Ref. No.	Part No.	Description	Spec Code	Quantity - AN80			
				96			
G2							

12004	12004-1060	VALVE-INTAKE	1
12005	12005-1056	VALVE-EXHAUST	1
12009	12009-1052	RETAINER-VALVE SPRING	2
12011	12011-1002	COLLET, SPLIT KEEPER	4
12016	12016-1003	ARM-ROCKER	2
12020	12020-1009	SHAFT-ROCKER	2
16007	16007-1109	SEAT-SPRING	2
32085	32085-1129	STOPPER, ROCKER SHAFT	1
49078	49078-1053	SPRING-ENGINE VALVE, INNER	2
49078A	49078-1054	SPRING-ENGINE VALVE, OUTER	2
92009	92009-1109	SCREW, VALVE ADJUST	2
92015	92015-1137	NUT, VALVE ADJUST LOCK	2
92049	92049-1062	SEAL-OIL, RVC2-5, 5X8, 5X8, 3	2
220	220B0614	SCREW-PAN-CROS, 6X14	2

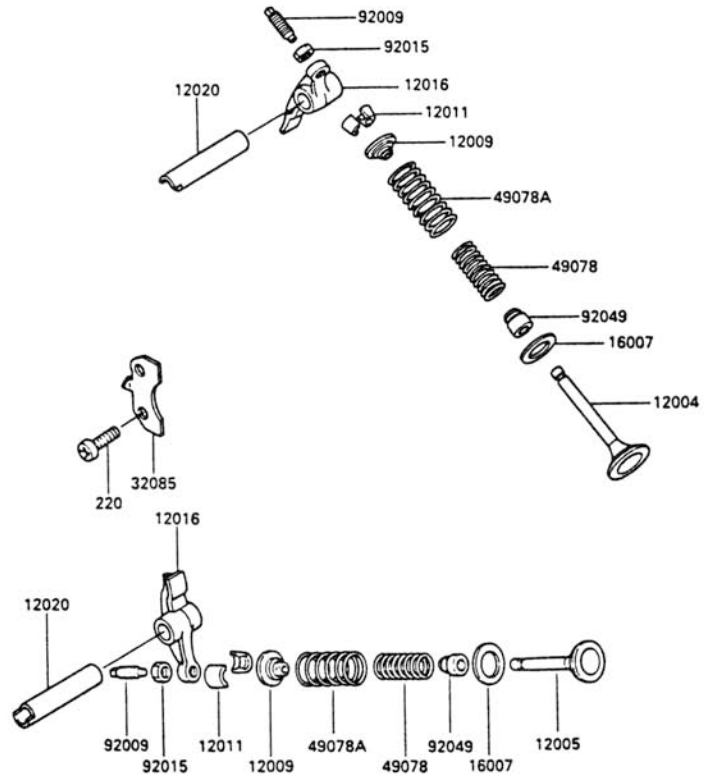

This catalog covers:
 '96 AN80-G2 Engine

GRID NO.
B-8

This grid covers:
Camshaft/Tensioner

E1230-0044

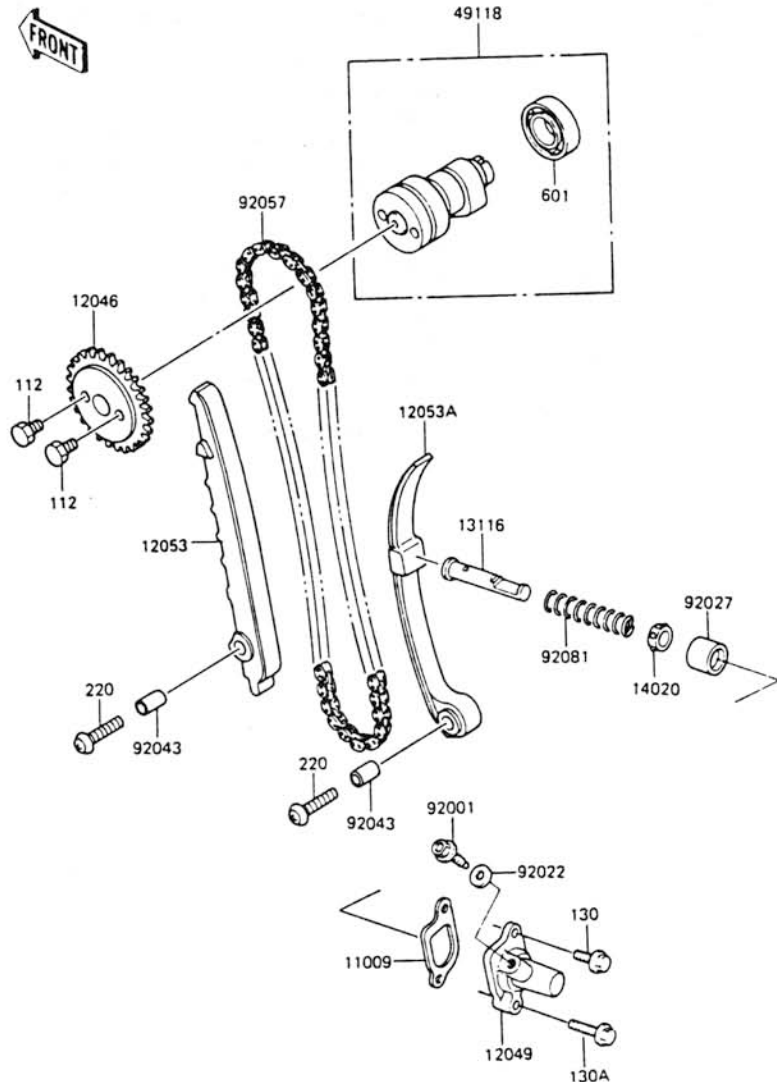

Ref. No.	Part No.	Description	Spec Code	Quantity - AN80			
				96			
				G2			
11009	11060-1500	GASKET CHAIN TENSIONER		1			
12046	12046-1035	SPROCKET, CAM CHAIN		1			
12049	12049-1059	TENSIONER, CAM CHAIN		1			
12053	12053-1086	GUIDE-CHAIN		1			
12053A	12053-1106	GUIDE-CHAIN		1			
13116	13116-1105	ROD-PUSH, TENSIONER		1			
14020	14020-1058	RETAINER, TENSIONER		1			
49118	49118-1004	CAMSHAFT-COMP					
92001	92001-1155	BOLT, TENSIONER ADJUST		1			
92022	92022-077	WASHER 6.1 X 12 X 1		1			
92027	92027-1733	COLLAR, TENSIONER		1			
92043	92042-007	PIN DOWEL 6.3X8X14		2			
92057	92057-1060	CHAIN, CAM 25HX82L		1			
92081	92081-1866	SPRING, TENSIONER		1			
112	112G0610	BOLT - UPSET		2			
130	130Y0616	BOLT-FLANGED		1			
130A	130Y0625	BOLT-FLANGED		1			
220	220B0625	SCREW-PAN CROS, 6X25		2			
601	601A6002Z	BEARING - BALL, #6002Z		1			

This catalog covers:
 '96 AN80-G2 Engine

GRID NO.

B-9

This grid covers:

Crankshaft

E1321-0020

FRONT

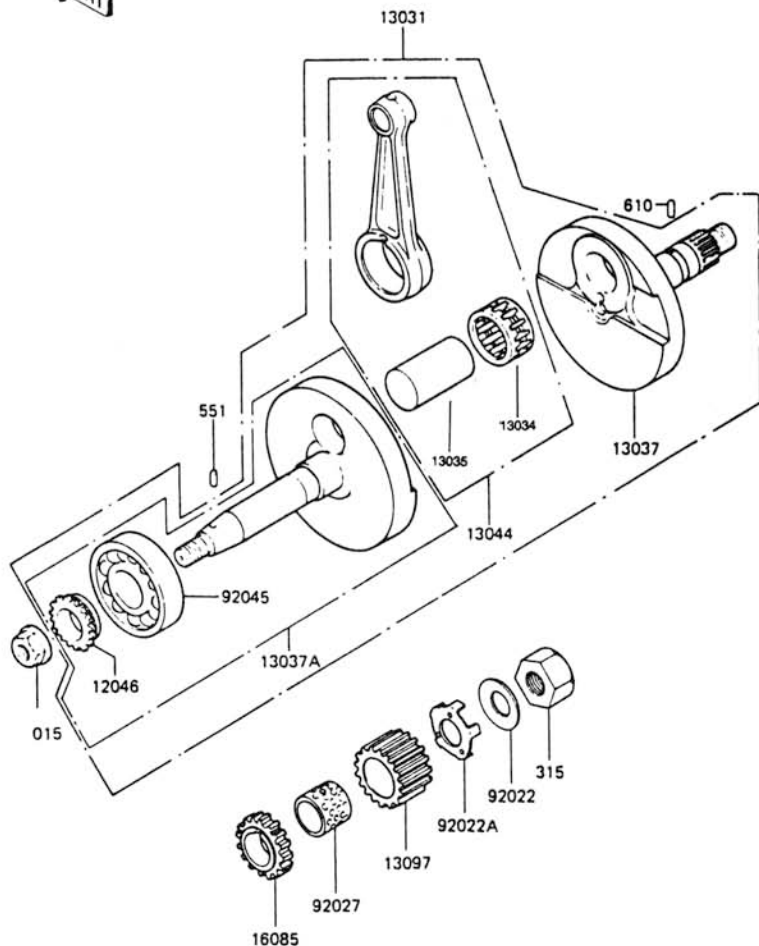

Ref. No.	Part No.	Description	Spec Code	Quantity - AN80			
				96			
			G2				
12046	12046-1060	SPROCKET, CAM CHAIN 14T		1			
13031	13031-1164	CRANKSFAFT-COMP		1			
13034	13034-1030	BEARING-BIG END		1			
13035	13035-1051	PIN-CRANK		1			
13037	13037-1107	CRANKSHAFT RH		1			
13037	13037-5031	CRANKSHAFT L.H.		1			
13044	13044-5032	SET-CONNECTING ROD		1			
13097	13097-1081	GEAR-PRIMARY SPUR 21T		1			
16085	16085-1114	GEAR OIL PUMP		1			
92015	92015-077	NUT, FLANGED 10 MM		1			
92022	92022-1232	WHASHER SPRONG 14MM		1			
92022	92022-1296	WASHER LOCK		1			
92027	92027-1897	COLLAR 18X22X20.5		1			
92045	92045-1107	BEARING-BALL #6304		1			
315	315B1400	NUT-HEX-FINE 14 MM		1			
551	551A0306	PIN-DOWEL 3X6		1			
610	610A0404	ROLLER 4X4		1			

E1340-0053

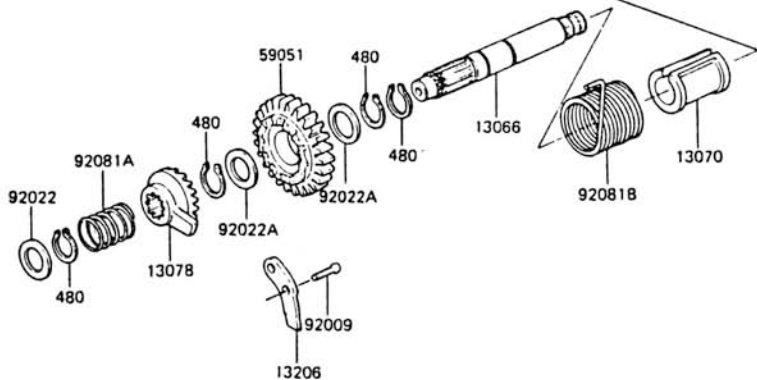
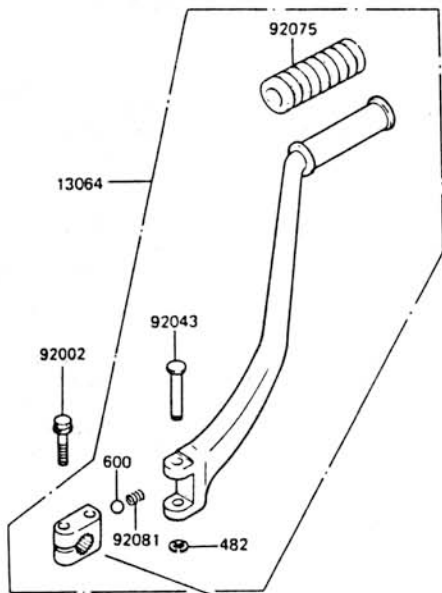

Ref. No.	Part No.	Description	Spec Code	Quantity - AN80			
				96			
13064	13064-1042/00	LEVER - ASSY - KICK, PEDAL		1			
	13064-1046	LEVER - ASSY - KICK, PEDAL (OPTION)		1			
13066	13066-1017	SHAFT - KICK		1			
13070	13070-1035	GUIDE, KICK SHAFT		1			
13078	13078-1052	RATCHET		1			
13206	13206-1006	GUIDE - KICK		1			
59051	59051-1123	GEAR - SPUR, KICK, 26T		1			
92002	92002-1237	BOLT, 6X20		1			
92009	92009-1104	SCREW, TAPPING		2			
92022	92022-1224	WASHER 13.2X20X0.5		1			
92022A	92022-315	WASHER 16.8X22X0.5		2			
92043	92043-1109	PIN 6X35.3		1			
92075	13063-002	DAMPER, PEDAL		1			
92081	92081-020	SPRING, KICK PEDAL		1			
92081A	92081-122	SPRING, RATCHET		1			
92081B	92081-1276	SPRING, KICK STARTER		1			
480	480J1600	CIRCLIP - TYPE - C, 16MM		4			
482	482L5000	CIRCLIP - TYPE - E, 5MM		1			
600	600A0800	BALL - STEEL, 1/4"		1			

This catalog covers:
'96 AN80-G2 Engine

GRID NO.

B-11

This grid covers:

Clutch

E1350-0029

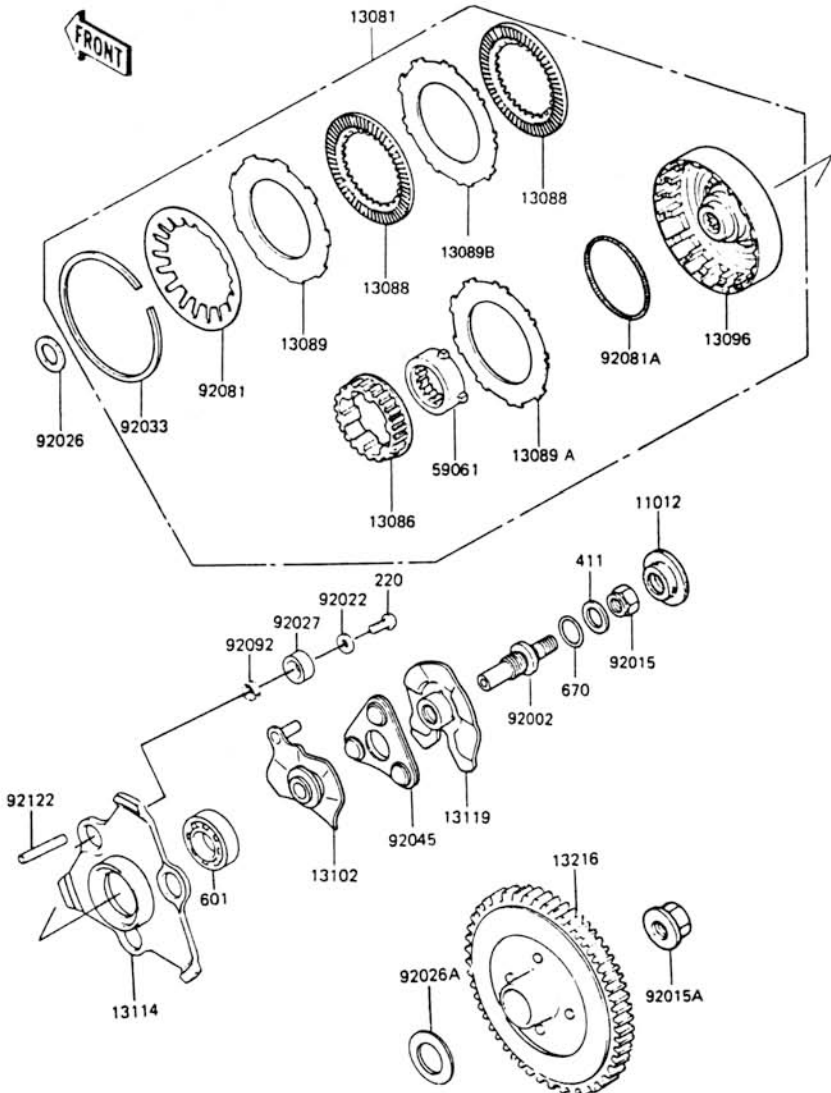

Ref. No.	Part No.	Description	Spec Code	Quantity - AN80			
				96			
51102	11012-1294	CAP CLUTCH COVER		1			
13081	13081-1323	CLUTCH-ASSY		1			
13086	13086-1054	WEEL-CLUTCH		1			
13088	13088-1012	PLATE-FRICTION		2			
13089	13089-1006	PLATE-CLUTCH		1			
13089A	13089-1061	PLATE-CLUTCH		1			
13089B	13089-1090	PLATE-CLUTCH		1			
13096	13096-1018	HOUSING-CLUTCH		1			
13102	13102-1073	RELEASE COMP-CLUTCH		1			
13114	13114-1054	PUSHER-CLUTCH		1			
13119	13119-1056	CAM-RELEASE CLUTCH		1			
13216	13216-1039	GEAR-COMP, CLUTCH		1			
59061	59061-1001	GEAR-INTERNAL		1			
92002	92002-1753	BOLT-CLUTCH RELEASE		1			
92015	92015-1136	NUT 8MM		1			
92015A	92015-1341	NUT, FLANGED 14 MM		1			
92022	92022-1312	WASHER 5.2X17X1		3			
92026	92026-1082	SPACER 18.5X30X1.6		1			
92026A	92026-1096	SPACER CLUTC 17X30X2		1			
92027	92027-1442	COLLAR 14X15X7.5		3			
92033	92033-1059	RING-SNAP		1			
92045	14020-1092	BEARING BALL CLUTCH RELEASE		1			
92081	92081-1326	SPRING CONICAL		1			
92081A	92081-1566	SPRING COIL		1			
92092	92092-1017	BUSHING-RUBBER 10.5X14X7.5		3			
92122	92122-1017	ROLLER		3			
220	220B0512	SCREW-PAN-CROS		3			
411	411B0800	WASHER-PLAIN 8MM		1			
601	601A6200Z	BEARING-BALL #6200Z		1			
670	670B1508	O'RING 8MM		1			

E1361-0070

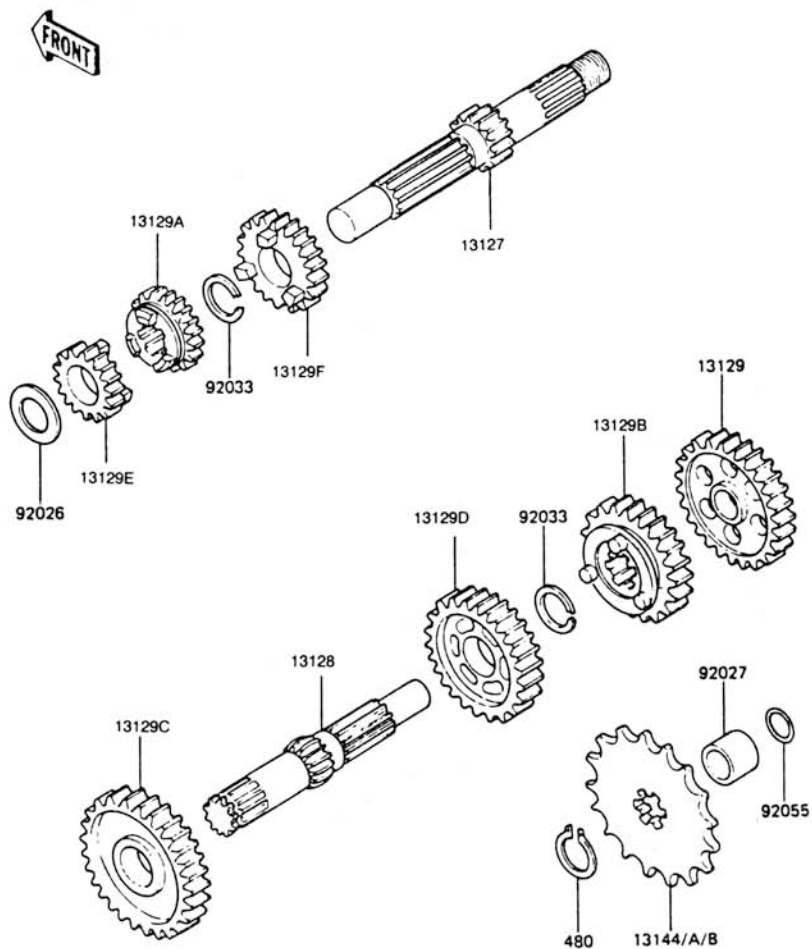

Ref. No.	Part No.	Description	Spec Code	Quantity - AN80			
				96			
13127	13127-1124	SHAFT-TRANSMISSION INPUT 13T		1			
13128	13128-1034	SHAFT-TRANSMISSION OUTPUT		1			
13129	13260-1320	GEAR, OUTPUT LOW 43T		1			
13129A	13129-1614	GEAR, INPUT 3RD,22T		1			
13129B	13129-1619	GEAR, OUTPUT TOP 31T		1			
13129C	13260-1045	GEAR, OUTPUT 2ND 38T		1			
13129D	13129-1618	GEAR, OUTPUT 3RD, 34T		1			
13129E	13129-1274	GEAR, INPUT 2ND, 18T		1			
13129F	13129-1270	GEAR, INPUT TOP, 25T		1			
13144	13144-1043	SPROCKET-OUTPUT 13T		1			
13144A	13144-1044	SPROCKET-OUTPUT, 14T					
13144B	13144-1045	SPROCKET-OUTPUT, 15T (OPTION)					
92096	92026-1091	SPACER		1			
92027	92027-1289	COLLAR, 17X22X10		1			
92033	92033-1060	RUBG0SNAP 17 MM		2			
92055	92055-1097	RING-O 17MM		1			
480	480J1700	CIRCLIP-TYPE-C 17MM		1			

This catalog covers:
 '96 AN80-G2 Engine

GRID NO.

B-13

This grid covers:
 Change Drum/Shift Fork

E1362-0024

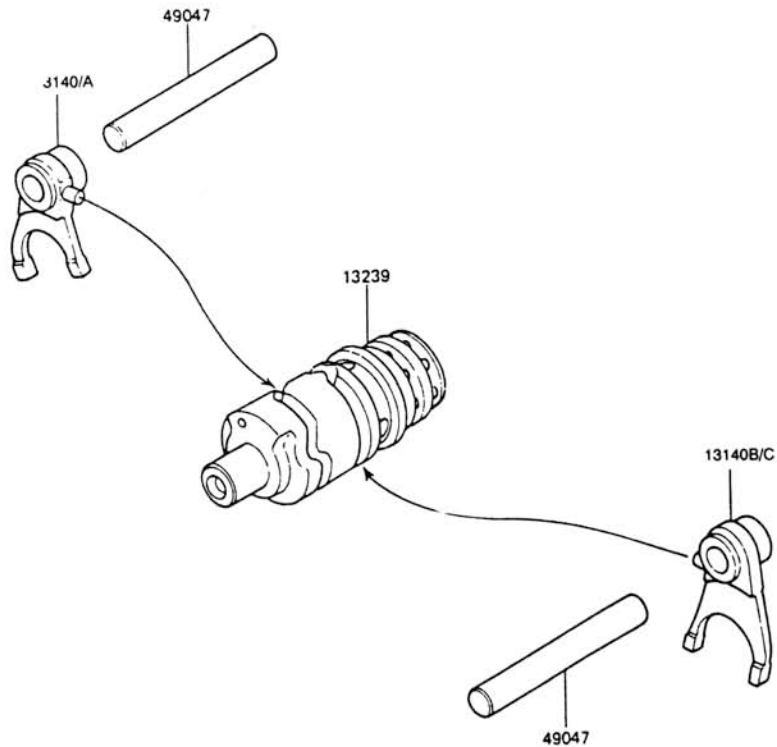

Ref. No.	Part No.	Description	Spec Code	Quantity - AN80			
				96			
13140A	13140-1118	FORK-SHIFT (PUNTA 4 MM)					1
13140B	13140-1110	FORK-SHIFT					1
13140C	13140-1119	FORK-SHIFT (PUNTA 4MM)					1
13239	13239-1052	DRUM-ASSY-CHANGE					1
40047	49047-1058	ROD-SHIFT					2

E1370-0121

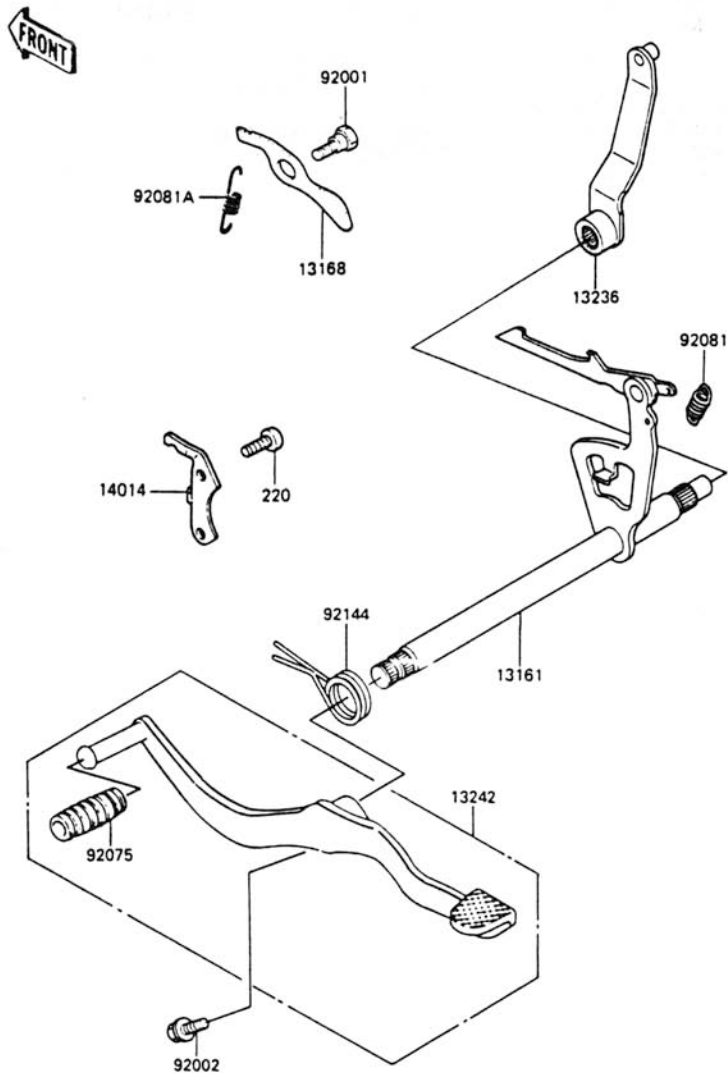

Ref. No.	Part No.	Description	Spec Code	Quantity - AN80			
				96			
13161	13161-1047	LEVER-COMP-CHANGE SHAFT		1			
13168	13168-1109	LEVER CHANGE		1			
13236	13236-1058	LEVER-COMP		1			
13242	13242-1079	LEVER ASSY-CHANGE		1			
14014	14014-1026	PLATE-PSITION		1			
92001	92150-1450	BOLT CHANGE DRUM LEVER		1			
92002	92002-1237	BOLT 6X20		1			
92075	92160-1036	DAMPER CHANGE PEDAL		1			
92081	92081-076	SPRING CHANGE LEVER		1			
92081A	92081-1118	SPRING COIL		1			
92144	92144-1107	SPRING CHANGE SHAFT RETURN		1			
220	220B0614	SCREW-PAN CROS 6X14		1			

E1411-0104

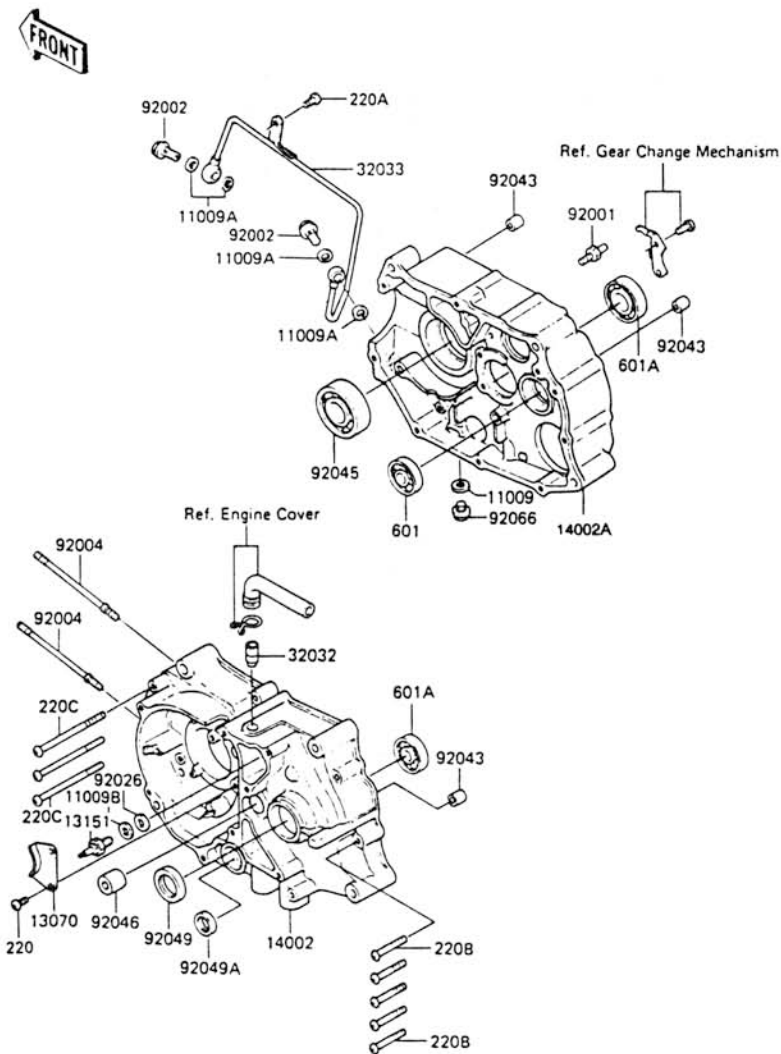

Ref. No.	Part No.	Description	Spec Code	Quantity - AN80			
				96			
				G2			
11009	11009-1332	GASKET DRAIN PLUG					1
11009A	11009-1344	GASKET OIL PIPE 8.2X14					4
11009B	92065-058	GASKET 10.5X16X1					1
13070	13070-1046	GUIDE CAM CHAIN					1
13151	13151-1008	SWITCH COMP NEUTRAL					1
14002	14002-1334	CRAN KCASE LH					1
14002A	14002-1341	CRAN KCASE RH					1
32032	32032-1516	PIPE BREATHER					1
32033	32033-1166	PIPOE-A OIL					1
92001	92001-1401	BOLT RETURN SPRING					1
92002	92150-1556	BOLT BANJO 8X22					2
92004	92004-1108	STUD 6X83					2
92026	92026-1002	SPACER 1-X18X0.5					AR
92043	92043-1263	PIN 6.2X8X14					4
92045	92045-1107	BEARING-BALL #6304					1
92046	92046-1034	BEARING-NEEDLE BK1312					1
92049	92049-1048	SEAL OIL SC22325					1
92049A	92051-005	SEAL OIL TB13225-5					1
92066	92066-1174	PLUG OIL DRAIN 12X15					1
220	220B0614	SCREW-PAIN-CROS 6X14					2
220A	220X0612	SCREW-PAN-CROS					1
220B	220X0635	SCREW-PAN-CROS					5
220C	220X0675	SCREW-PAN-CROS					3
601	601A6201	BEARING-BALL					1
601A	601A6203	BEARING-BALL #6203					2

This catalog covers:
'96 AN80-G2 Engine

GRID NO.

C-4

This grid covers:
Engine Cover

E1431-0139

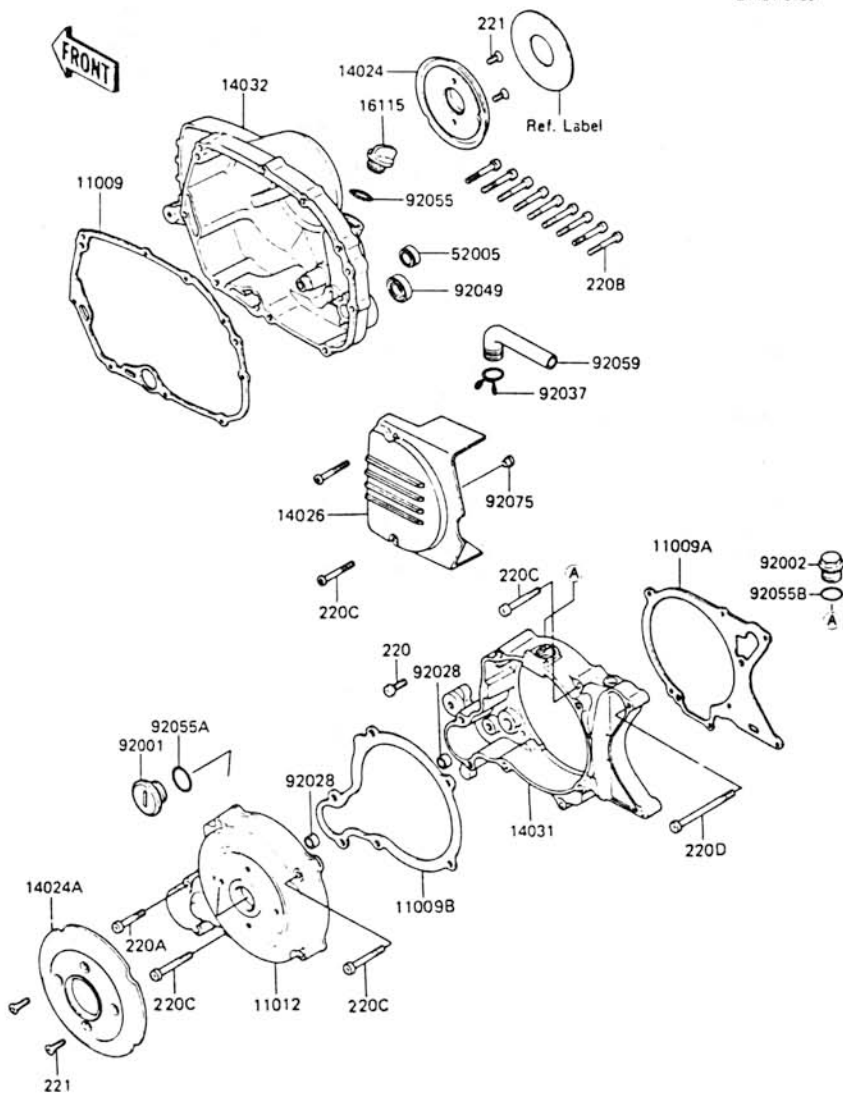

Ref. No.	Part No.	Description	Spec Code	Quantity - AN80	
				96	G2
11009	11060-1536	GASKET CLUTCH COVER		1	
11009A	11060-1584	GASKET GENERATOR COVER		1	
11009B	11060-1595	GASKET GENERATOR COVER		1	
11012	11012-1395	CAP GENERATOR COVER		1	
14024	14025-1677	COVER CLUTCH COVER		1	
14024A	14025-1872	COVER GENERATOR CAP		1	
14026	14026-1106	COVER CHAIN		1	
14031	14031-1157	COVER GENERATOR		1	
14032	14032-1115	COVER CLUTCH		1	
16115	16115-1013	CAP OIL FILLER		1	
52005	52005-1055	GAUCE OIL LEVEL		1	
92001	92001-1827	BOLT GENERATOR COVER CAP		1	
92002	92002-1238	BOLT 16X10		1	
92028	92028-1189	BUSHING		2	
92037	92037-192	CLAMP BREATHER TUBE		1	
92049	92051-003	SEAL OIL TB16217		1	
92055	92055-012	RING-0		1	
92055A	92055-1136	RING 0.25.7X2.4		1	
92055-B	92055-1141	RING-O.ID=13.8		1	
92059	92059-1167	TUBE BREATHER		1	
92075	92075-1090	DAMPER L=9.5		1	
220	220B0616	SCREW PAN CROS 6X16		1	
220A	220X0630	SCREW PAN CROS		2	
220B	220X0635	SCREW PAN CROS		10	
220C	220X0640	SCREW PAN CROS		7	
220D	220X0675	SCREW PAN CROS		1	
221	221B0510	SCREW CSK CROS		6	

E1611-0149

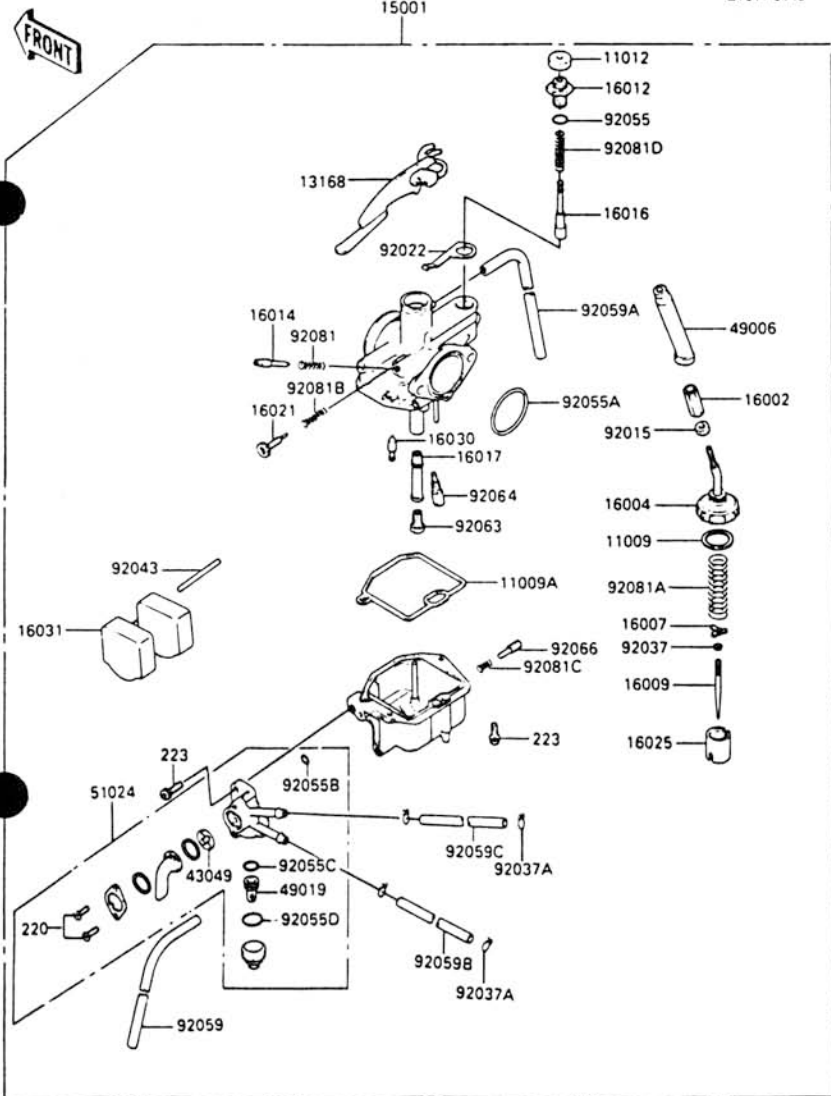

Ref. No.	Part No.	Description	Spec Code	Quantity - AN80			
				96	G2		
11009	11009-1283	GASKET, CHAMBER CAP				1	
11009A	11009-1405	GASKET, FLOAT CHAMBER				1	
11012	11012-1387	CAP, STARTER PLUNGER				1	
13168	13168-1227	LEVER, STARTER PLUNGER				1	
15001	15001-1447	CARBURETTOR				1	
16002	16002-1010	ADJUSTER-CABLE				1	
16004	16004-1014	CAP-CHAMBER				1	
16007	16007-1110	SEAT-SPRING				1	
16009	16009-1221	NEEDLE-JET, 4071				1	
16012	16012-1053	CAP-STARTER PLUNGER				1	
16014	16014-1022	SCREW-PILOT AIR				1	
16016	16016-1053	PLUNGER, STARTER				1	
16017	16017-1221	JET-NEEDLE				1	
16021	16021-1107	SCREW-THROTTLE STOP				1	
16025	16025-1108	VALVE-THROTTLE				1	
16030	16030-1054	VALVE-FLOAT				1	
16031	16031-1019	FLOAT				1	
43049	43049-1051	PACKING, FUEL TAP				1	
49006	49006-1074	BOOT, CABLE ADJUSTER				1	
49019	49019-1952	FILTER-FUEL, TAP				1	
51024	51024-1051	TAP				1	
92015	92015-1092	NUT, CABLE ADJUSTER LOCK				1	
92022	92022-1256	WASHER, STARTER PLUNGER				1	
92037	92037-1303	CLAMP				1	
92037A	92037-1307	CLAMP, TUBE				4	
92043	92043-1066	PIN, FLOAT				1	
92055	92055-1127	RING-O				1	
92055A	92055-1236	RING-O, CARBURETTOR				1	
92055B	92055-1237	RING-O FUEL TAP				1	
92055C	92055-1238	RING-O, FILTER				1	
92055D	92055-1239	RING-O FUEL TAP				1	
92059	92059-1219	TUBE, 3X5X250				1	
92059A	92059-1220	TUBE, 4X7X130				1	
92059B	92059-1427	TUBE, 5X9X580				1	
92059C	92059-1428	TUBE, 5X9X590				1	
92063	92063-1121	JET-MAIN, N76				1	
92064	92064-1158	JET-PILOT				1	
92066	92066-1170	PLUG, DRAIN				1	
92081	92081-1202	SPRING, PILOT AIR SCREW				1	
92081A	92081-1686	SPRING, THROTTLE VALVE				1	

E1611 0179

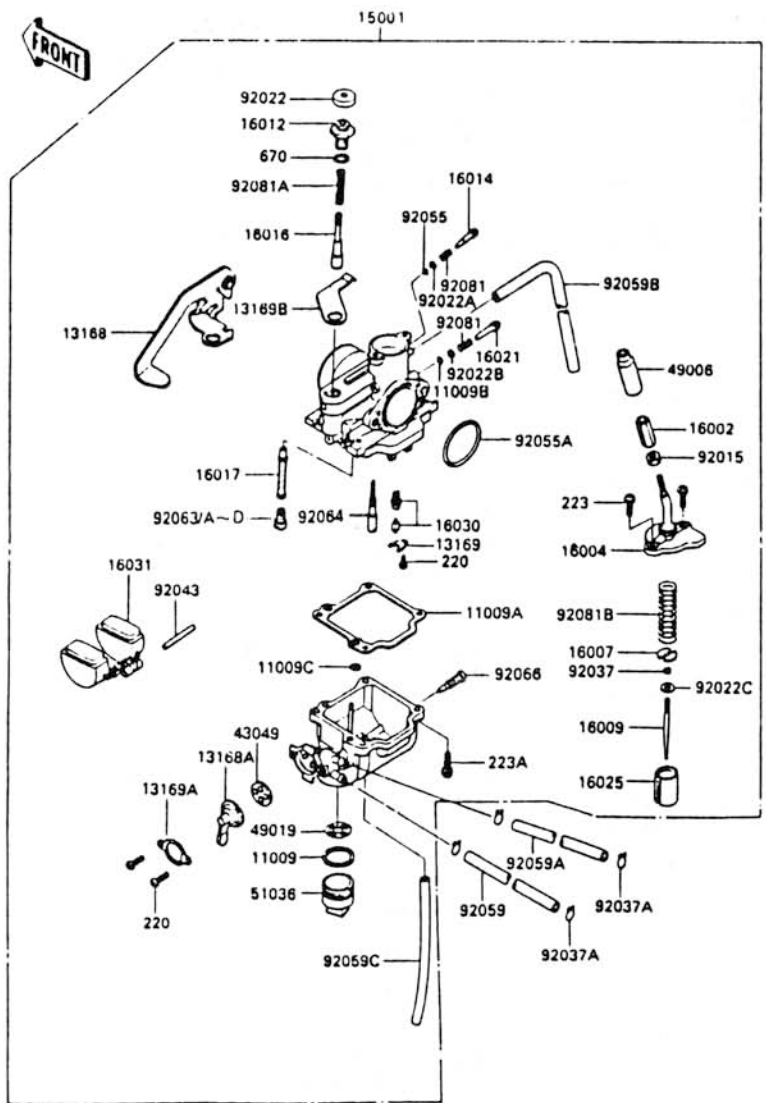

Ref. No.	Part No.	Description	Spec Code	Quantity - AN80			
				96			
92081B	92081-1692	SPRING, STOP SCREW		1			
92081C	92081-1693	SPRING, DRAIN PLUG		1			
92081D	92081-1694	SPRING, STARTER PLUNGER		1			
220	220B0306	SCREW-PAN-CROS		2			
223	223B0412	SCREW-PAN-WS-CROS		4			

This catalog covers:
 '96 AN80-G2 Engine

GRID NO.

C-6

This grid covers:
 Carburettor Mikuni (1/2)

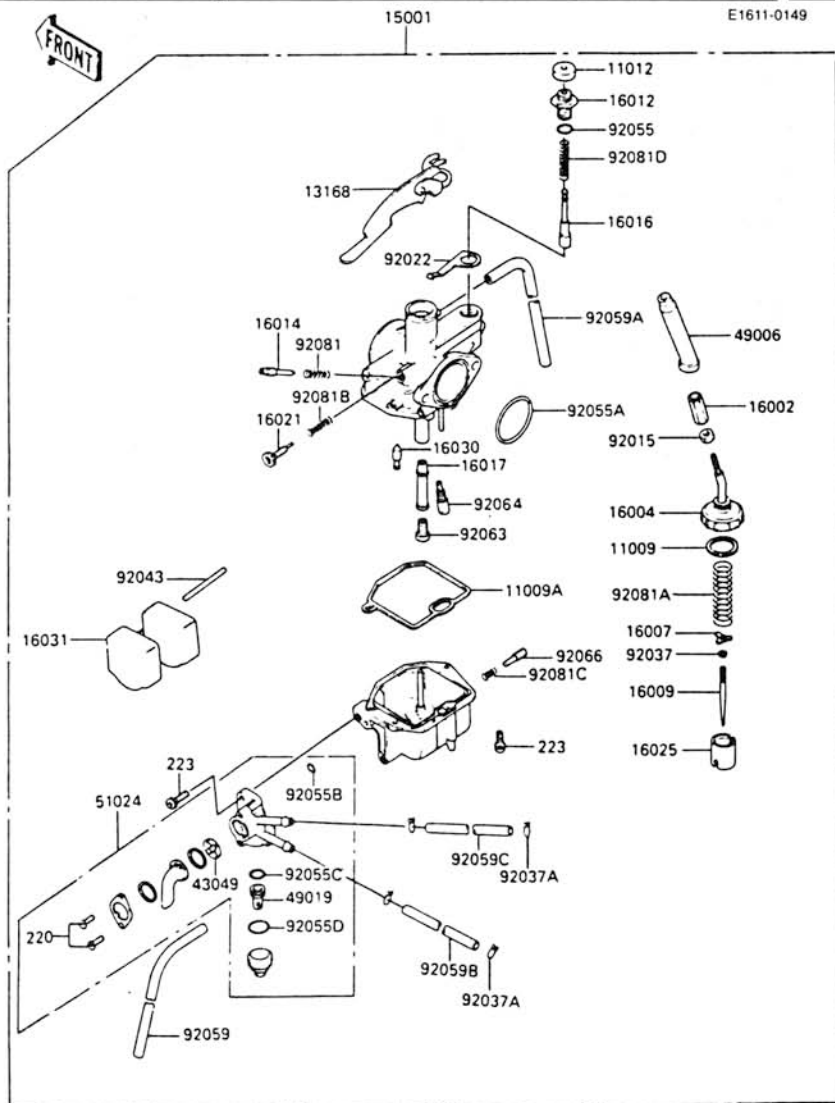

Ref. No.	Part No.	Description	Spec Code	Quantity - AN80			
				96			
				G2			
11009	11009-1527	GASKET, FUEL TAP		1			
11009A	11009-1528	GASKET, FLOAT CHAMBER		1			
11009B	16038-022	GASKET, "O" RING		1			
11009C	16038-024	GASKET		1			
13168	13168-1271	LEVER, STARTER		1			
13168A	13168-1272	LEVER, FUEL TAP		1			
13169	13169-1809	PLATE, LOCK		1			
13169A	13169-1947	PLATE, FUEL TAP		1			
13169B	13169-1949	PLATE		1			
15001	15001-1532	CARBURETTOR-ASSY		1			
16002	16002-004	ADJUSTER-CABLE		1			
16004	16004-1057	CAP-CHAMBER		1			
16007	16007-1116	SEAT-SPRING		1			
16009	16009-1536	NEEDLE-JET, 3J19-3		1			
16012	16012-019	CAP-STARTER PLUNGER		1			
16014	16014-1020	SCREW-PILOT AIR		1			
16016	16016-1002	PLUNGER, STARTER		1			
16017	16017-1289	JET-NEEDLE, E-2		1			
16021	16021-1113	SCREW-THROTTLE STOP		1			
16025	16025-1121	VALVE-THROTTLE, CA 3.5		1			
16030	16030-1061	VALVE-FLOAT, 1.5		1			
16031	16031-1061	FLOAT		1			
43049	43049-1052	PACKING, FUEL TAP		1			
49006	49006-1084	BOOT, CABLE ADJUSTER		1			
49019	49019-1054	FILTER-FUEL		1			
51036	51036-1052	CUP, FUEL TAP		1			
92015	16003-004	NUT, CABLE ADJUST LOCK		1			
92022	16039-015	CAP, RUBBER, STARTER PLUNGER		1			
92022A	92022-1187	WASHER, ADJUST SCREW		1			
92022B	92022-1698	WASHER, THROTTLE STOP SCREW		1			
92022C	92022-1699	WASHER		1			
92037	92037-1272	CLAMP		1			
92037A	92037-1610	CLAMP		4			
92043	92043-1126	PIN, FLOAT		1			
92055	92055-1078	RING-O, ADJUST SCREW		1			
92055A	92055-1305	RING-O		1			
92059	92059-1427	TUBE, 5X9X580		1			
92095A	92059-1428	TUBE, 5X9X590		1			
92059B	92059-1592	TUBE, 3, 5X6, 5X100		1			
92059C	92059-1593	TUBE, 3X5X175		1			

E1611-0179

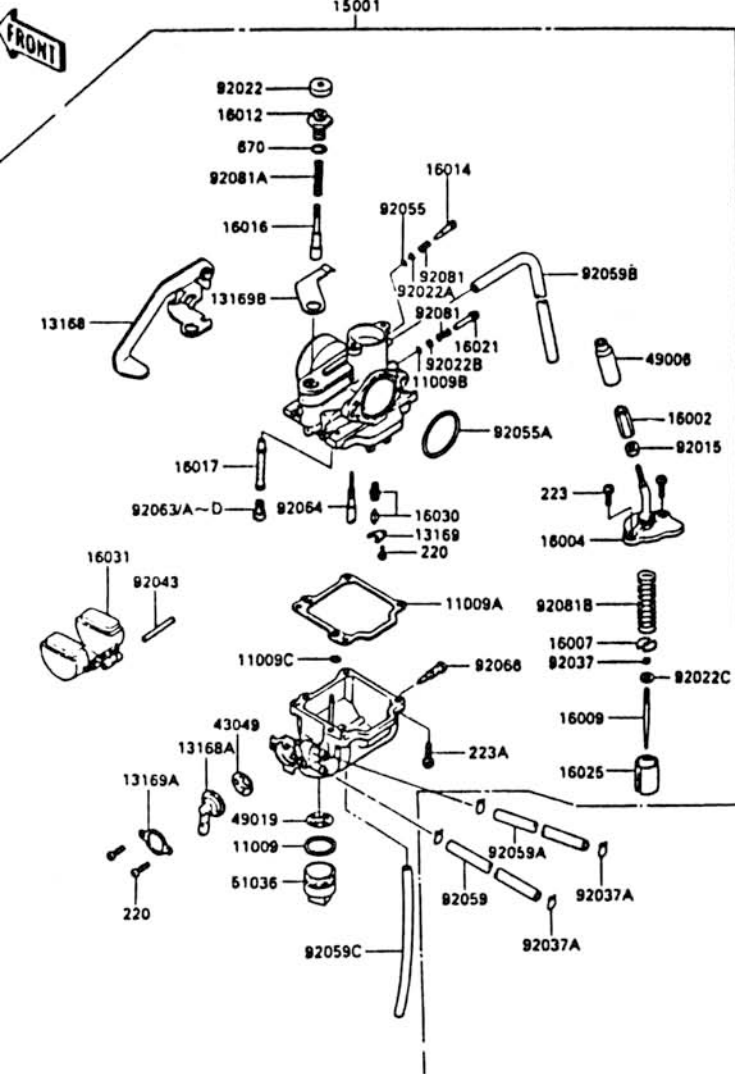

Ref. No.	Part No.	Description	Spec Code	Quantity - AN80			
				96			
92063	92063-1313	JET-MAIN, #70				1	
92063A	92063-1314	JET-MAIN, #72.5				1	
92063B	92063-1341	JET-MAIN, #62.5				1	
92063C	92063-1342	JET-MAIN, #65				1	
92063D	92063-1343	JET-MAIN, #67.5 (STD FOR COLOMBIA MODEL)				1	
92064	92064-1116	JET-PILOT, #15				1	
92066	92066-1171	PLUG, DRAIN				1	
92081	92081-1153	SPRING, STOP SCREW				2	
92081A	92081-1398	SPRING				1	
92081B	92081-1867	SPRING, THROTTLE VALVE				1	
220	220B0306	SCREW-PAN-CROS				3	
223	223B0412	SCREW-PAN-WS-CROS				2	
223A	223B0414	SCREW-PAN-WS-CROS				4	
670	670B1509	O RING, 9MM				1	

E1710-0057

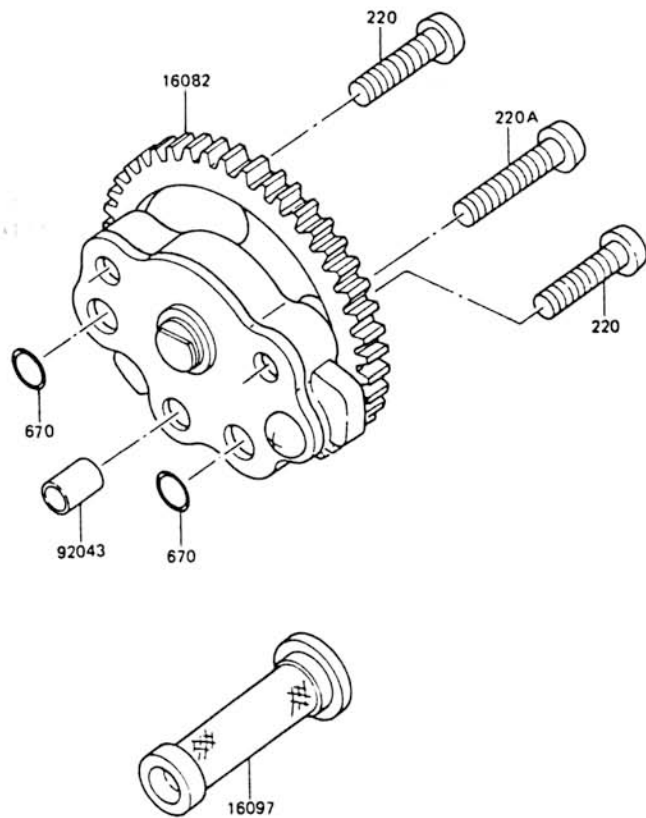

Ref. No.	Part No.	Description	Spec Code	Quantity - AN80			
				96			
16082	16082-1052	PUMP-ASSY-OIL		1			
16097	16097-1051	FILTER-ASSY-OIL		1			
92043	92043-1263	PIN, 6, 2X8X14		1			
220	220B0625	SCREW-PAN-CROS, 6X25		2			
220A	220B0630	SCREW-PAN-CROS, 6X30		1			
670	670B1510	O RING, 10MM		2			

E1810-0101

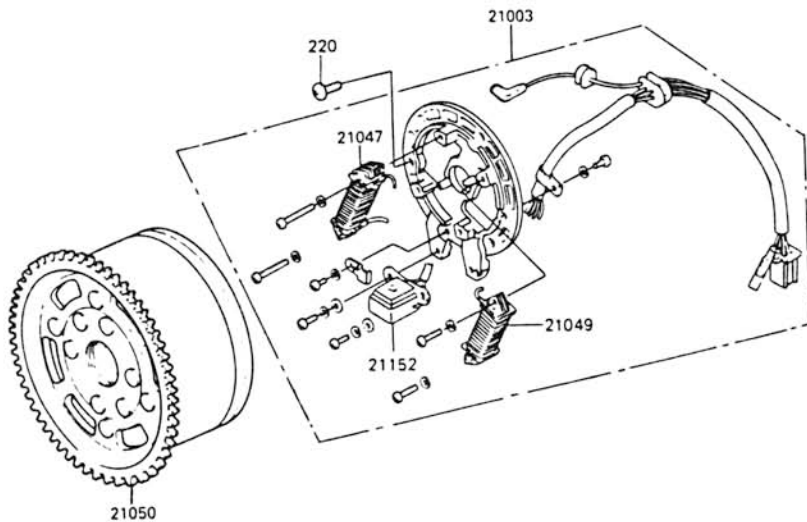
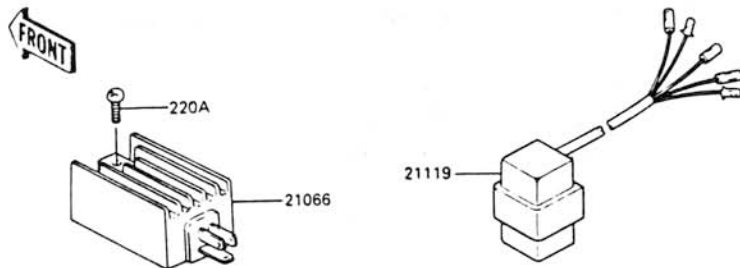

Ref. No.	Part No.	Description	Spec Code	Quantity - AN80			
				96			
21003	21003-1063	STATOR		1			
21047	21047-1024	COIL-LIGHTING		1			
21049	21049-1017	COIL-EXCITING		1			
21050	21050-1101	FLYWHEEL		1			
21066	21066-1023	REGULATOR-VOLTAGE		1			
21119	21119-1112	IGNITER		1			
21152	21152-1001	PICKUP-GENERATOR		1			
220	220B0514	SCREW-PAN-CROS		3			
220A	220B0630	SCREW-PAN-CROS. 6X30		1			

This catalog covers:
'96 AN80-G2 Engine

GRID NO.

C-9

This grid covers:
Ignition Coil

E1830-0057

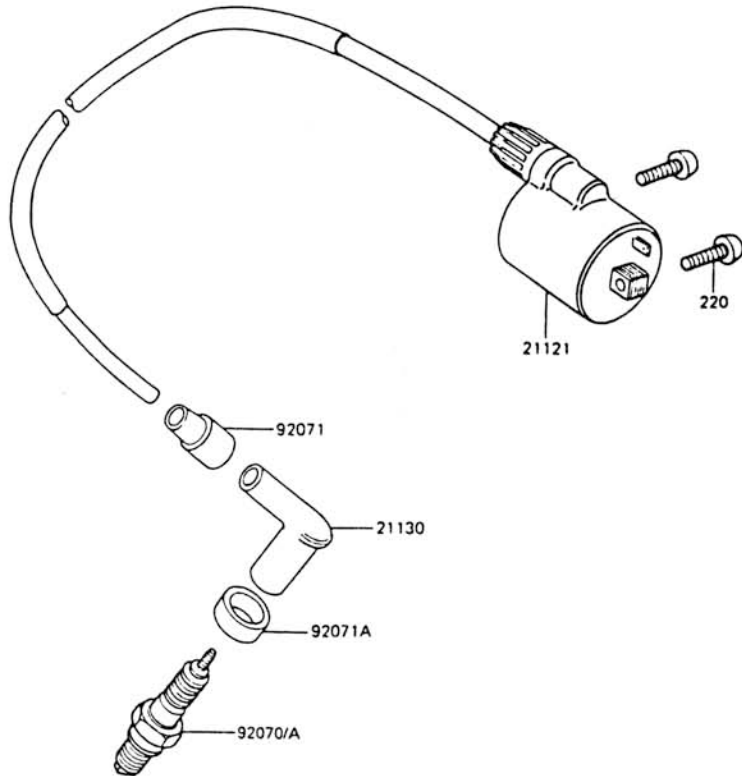

Ref. No.	Part No.	Description	Spec Code	Quantity - AN80			
				96			
21121	21121-1061	COIL-IGNITION		1			
21130	21130-1003	CAP-SPARK PLUG		1			
92070	92070-1107	PLUG-SPARK, C7HSA (NGK)		1			
92070A		PLUG-SPARK, U22FS-U(ND) (LOCAL PROCUREMENT ITEM)		1			
92071	21132-005	GROMMET, HIGH TENSION		1			
92071A	92071-1015	GROMMET, SPARK PLUG CAP		1			
220	220B0516	SCREW-PAN-CROS		1			

E1810-0059

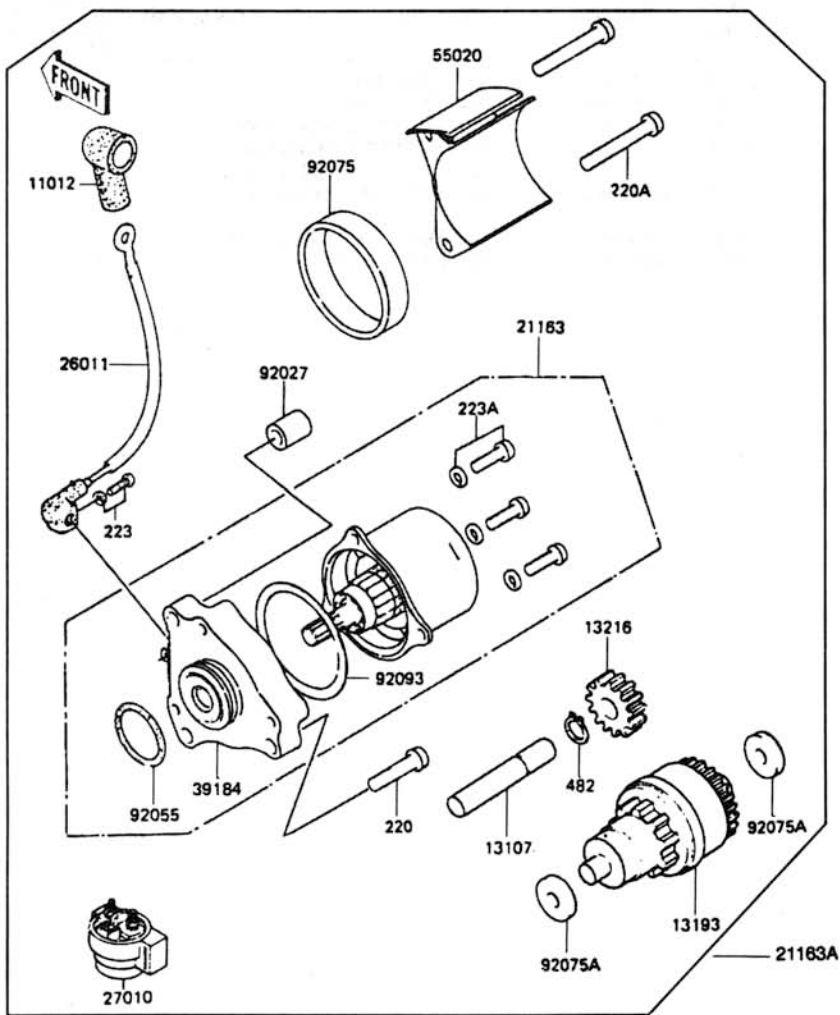

Ref. No.	Part No.	Description	Spec Code	Quantity - AN80			
				96			
				G2			
11012	11012-1354	CAP TERMINAL		1			
13107	13107-1027	SHAFT STARTER GEAR		1			
13193	13193-1010	CLUTCH ASSY ONEWAY		1			
13216	13216-1028	GEAR COMP 26T		1			
21163	21163-1083	STARTER ELECTRIC		1			
21163A	21163-1083-AC	STARTER ELECTRIC COMP.		1			
26011	26011-1272	WIRE LEAD STARTER MOTOR		1			
27010	27010-1075	SWITCH, STARTER		1			
39184	39184-1056	BRACKET ASSY STARTER		1			
55020	55020-1083	GUARD		1			
92027	92027-1461	COLLAT		2			
92055	21027-004	RING 0 25 MM		1			
92075	92075-1392	DAMPER		1			
92075A	92075-1415	DAMPER		2			
92093	92093-1079	SEAL		1			
220	220B0625	SCREW PAN CROS		1			
220A	220B0640	SCREW PAN CROS		2			
223	223D0406	SCREW PAN WS CROS		1			
223A	223D0516	SCREW PAN WS CROS		3			
482	482J6000	CIRCLIP TYPE W 6MM		1			
	ESCOB-5857/00	JUEGO ESCOBILLAS		1			

N.I.

This catalog covers:
 '96 AN80-G2 Chassis

GRID NO.

D-3

This grid covers:
 Frame

F2120-0232

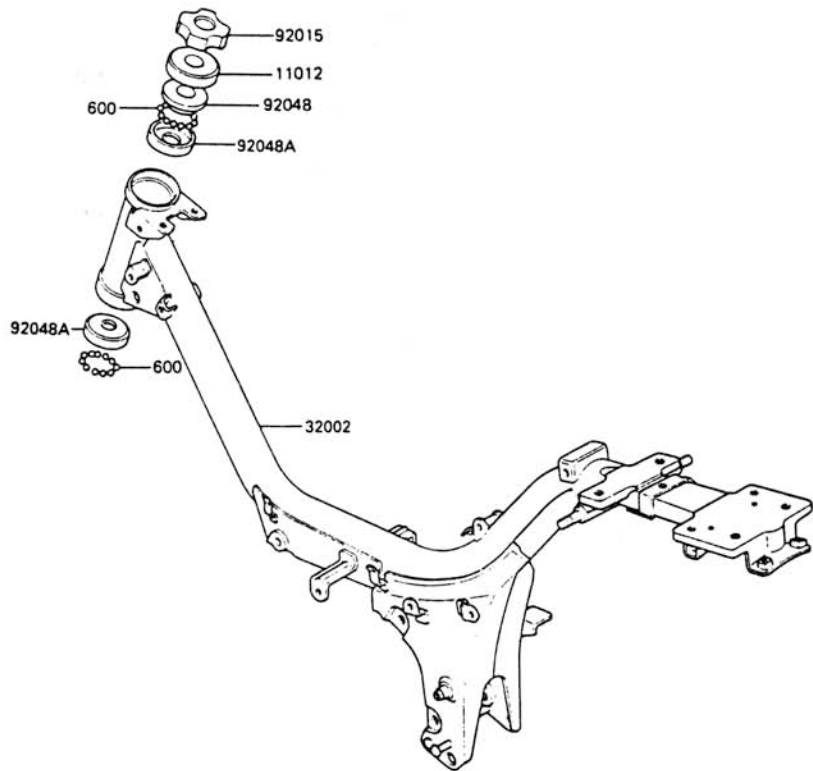

Ref. No.	Part No.	Description	Spec Code	Quantity - AN80				
				96				
11012	46098-004	CAP, STEERING STEM		1				
32002	32002-1673	FRAME-COMP		1				
92015	92090-006	NUT, STEERING STEM LOCK 25MM		1				
92048	92047-014	CONE, STEERING STEM BEARING		1				
92048A	92048-009	RACE, STEERING STEM BEARING		2				
600	600A0600	BALL-STEEL, 3/16"		46				

F2131-0171

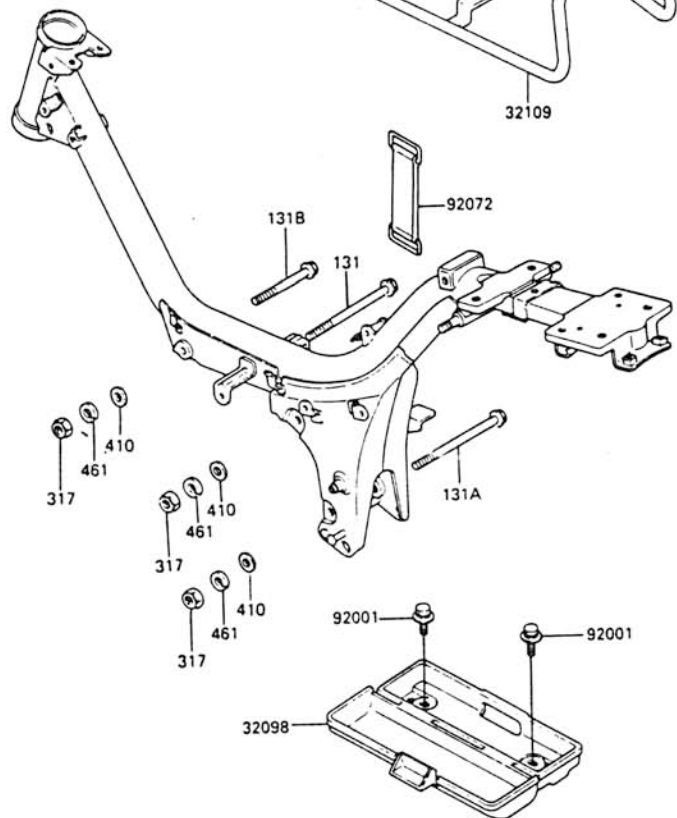
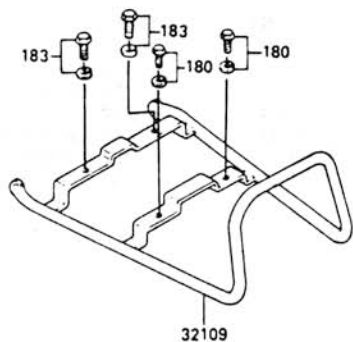

Ref. No.	Part No.	Description	Spec Code	Quantity - AN80			
				96			
			G2				
32098	32098-1052	CASE TOOL		1			
32109	32109-1104/00	GRIP FRAME		1			
92001	92001-1762	BOLT, W/SP. 6X14		2			
92072	92072-006	BAND L=142.1		1			
131	131G08105	BOLT FLANGED 8X105		1			
131A	131G08110	BOLT FLANGED		1			
131B	131G0875	BOLT FLANGED 8X75		1			
180	180B0616	BOLT UPSET WS		2			
183	183B0820	BOLT UPSET WS SMALL		2			
317	317B0800	NUT HEX SMALL 8MM		3			
410	410B0800	WASHER PLAIN SMALL 8MM		3			
461	461F0800	WASHER SPRING 8MM		3			

This catalog covers:
 '96 AN80-G2 Chassis

GRID NO.

D-5

This grid covers:
Swing Arm/Shock Absorber

F2140-0185

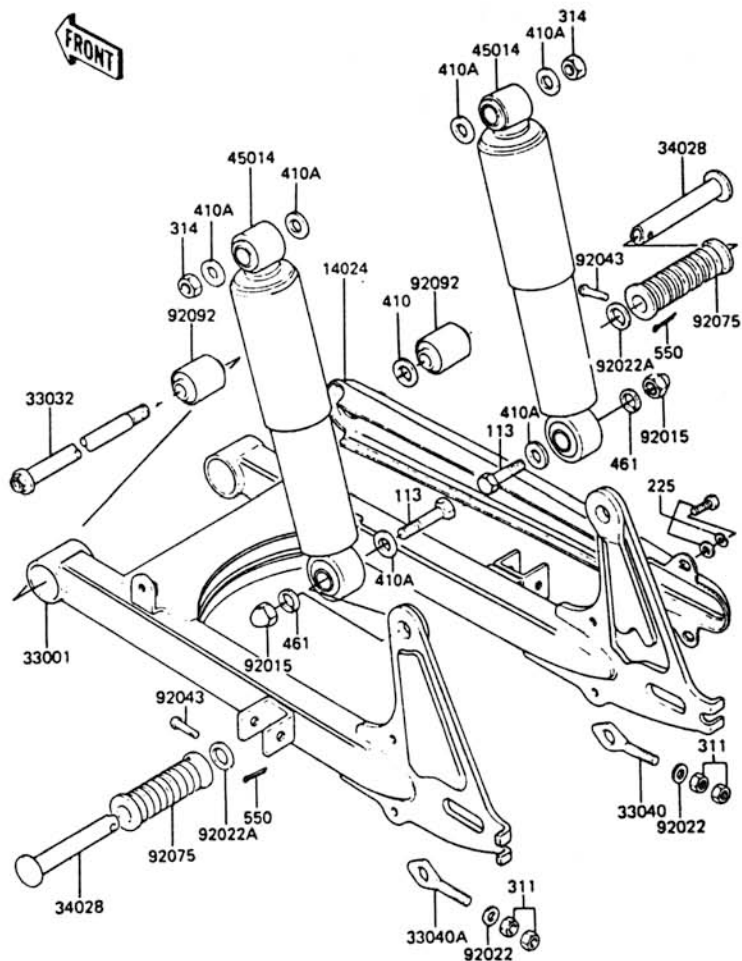

Ref. No.	Part No.	Description	Spec Code	Quantity - AN80			
				96			
14024	14025-1788	COVER, SWING ARM		1			
33001	33001-1099	ARM-COM-SWING		1			
33032	33032-1018/00	SHAFT-SWING ARM		1			
33040	33040-008	ADJUSTER-CHAIN, RH		1			
33040A	33040-010	ADJUSTER-CHAIN, LH		1			
34028	34028-009/00	STEP, RR		2			
45014	45014-1176	SHOCK ABSORBER, REAR		2			
92015	92020-014	NUT, CAP, 12 MM		2			
92022	92022-116	WASHER, 6.5X16X2		2			
92022A	92022-1568	WASHER, 20X30X2.3		2			
92043	92043-079	PIN, 6X28		2			
92075	92076-020	DAMPER		2			
92092	92092-006	BUSHING-RUBBER-SWING ARM SHAFT		2			
113	113B1245	BOLT-SMALL-FINE		2			
225	225B0612	SCREW-PAN-WSP-CROS		2			
311	311B0600	NUT-HEX, 6MM		4			
314	314B1200	NUT-HEX-FINE		2			
410	410B1000	WASHER-PLAIN-SMALL, 10MM		1			
410A	410B1200	WASHER-PLAIN-SMALL, 12MM		6			
461	461F1200	WASHER-SPRING, 12MM		2			
550	550D2015/00	PIN-COTTER, 2.0X15		2			

This catalog covers:
 '96 AN80-G2 Chassis

GRID NO.
D-6

This grid covers:
Step

F2160-0108



Ref. No.	Part No.	Description	Spec Code	Quantity - AN80			
				96			
34003	34003-1205/00	HOLDER STEP		1			
92075	92075-1675	DAMPER STEP		2			
183	183B0818	BOLT UPSET WS SMALL		4			

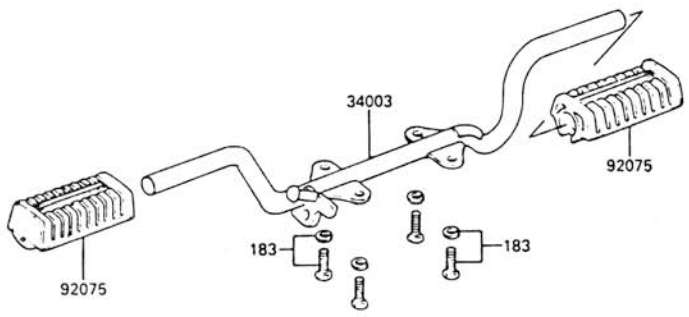

F2170-0075

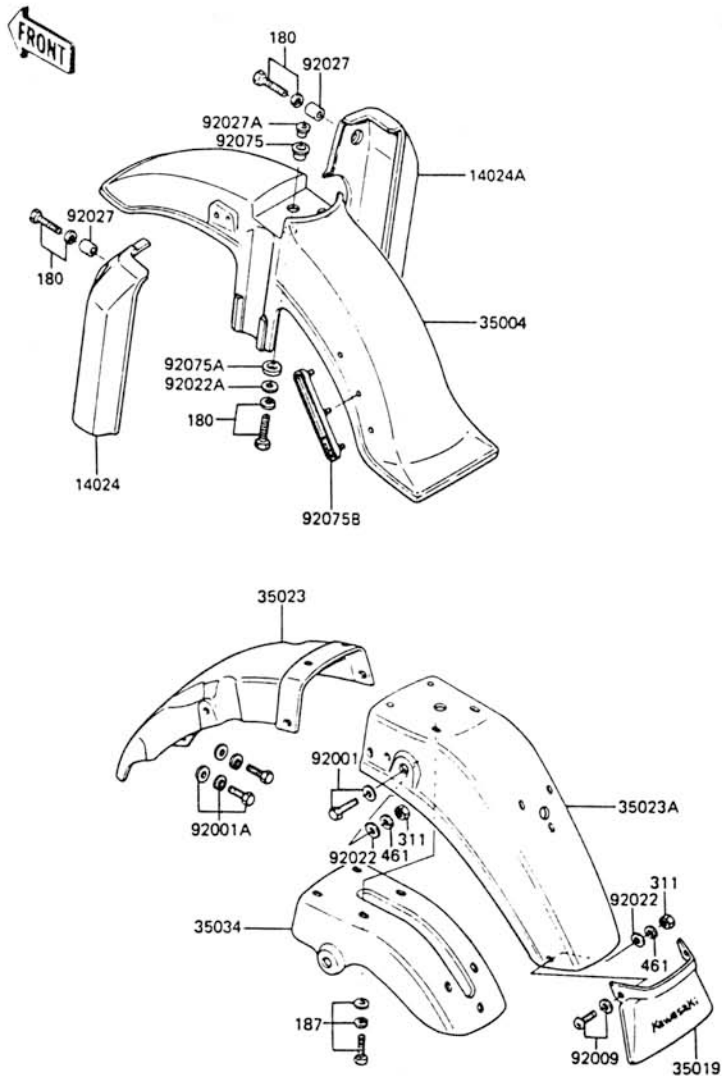

Ref. No.	Part No.	Description	Spec Code	Quantity - AN80				
				96				
14024	14025-1291	COVER, LH FENDER		1				
14024A	14025-1292	COVER, RH FENDER		1				
35004	35004-1063	FENDER-FRONT		1				
35019	35019-1027	FLAP, REAR FENDER		1				
35023	35023-1032	FENDER-REAR		1				
35023A	35023-1045	FENDER-REAR		1				
35034	35034-1074	REINFORCE, RR FENDER		1				
92001	92001-1860	BOLT, W/P, 6X16		2				
92001A	92001-1862	BOLT, W/SP, 6X14		2				
92009	92009-1273	SCREW, W/P, 6X16		2				
92022	92022-024	WASHER, 7X16X1.2		4				
92022A	92022-228	WASHER, 7X24X1.6		3				
92027	92027-129	COLLAR, 6.8X10X8.5		2				
92027A	92027-194	COLLAR, L=11.1		3				
92075	92075-103	DAMPER		3				
92075A	92075-121	DAMPER, FENDER		3				
92075B	92075-1370	DAMPER		1				
180	180B0622	BOLT-UPSET-WS		5				
187	187B0616	BOLT-UPSET-WSP		4				
311	311B0600	NUT-HEX, 6MM		4				
461	461F0600	WHASER-SPRING, 6MM		4				

F2190-0049

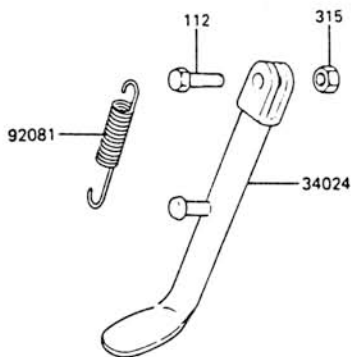
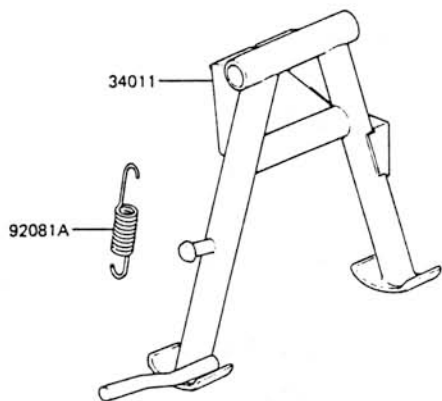

Ref. No.	Part No.	Description	Spec Code	Quantity - AN80				
				96				
34011	34011-1056/00	STAND CENTER		1				
34024	34024-1063/00	STAND SIDE		1				
92081	34025-005/00	SPRING STAND		1				
92081A	34025-008/00	SPRING STAND		1				
112	112C1030	BOLT UPSET		1				
315	315C1000	NUT HEX FINE 10MM		1				

F2210-0047

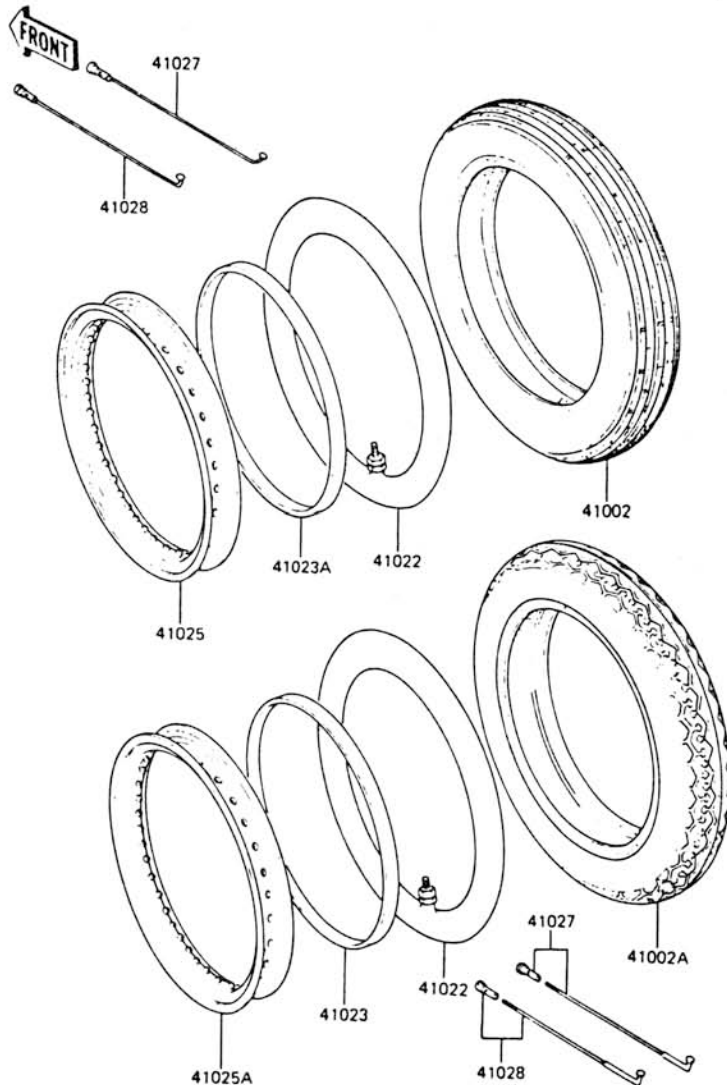

Ref. No.	Part No.	Description	Spec Code	Quantity - AN80			
				96			
41002	41002-1154	TIRE, FRONT, 2.25 - 17 4PR		1			
41002A	41002-1155	TIRE, REAR, 2.50-17 4PR		1			
41022	41022-1032	TUBE-TIRE, 2.25/2.50-17		2			
41023	41023-1002	BAND-RIM, 2.50/4.60-17(Y)		1			
41023A	41023-1020	BAND-RIM		1			
41025	41025-003	RIM, FR, 1.20X17		1			
41025A	41025-006	RIM, RR, 1.40 X 17		1			
41027	41027-074	SPOKE-ASSY-INNER		36			
41028	41028-073	SPOKE-ASSY-OUTER		36			

F2230-0040

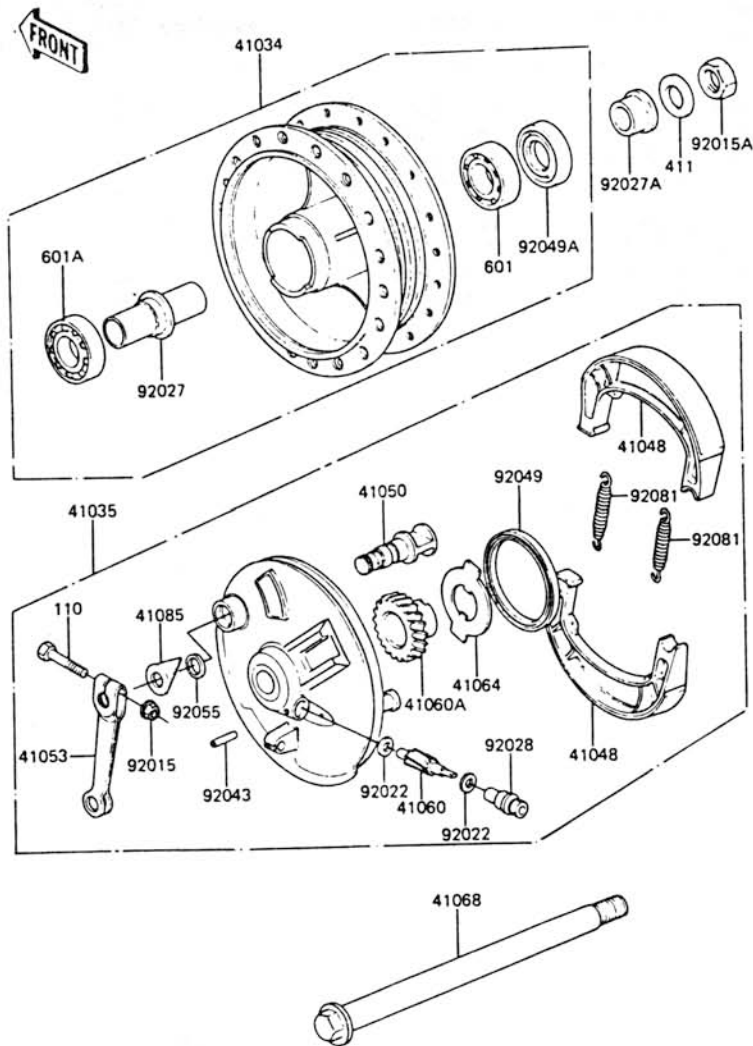

Ref. No.	Part No.	Description	Spec Code	Quantity - AN80			
				96			
41034	41034-1040	DRUM ASSY		1			
41035	41035-1466	PANEL ASSY BRAKE FRONT		1			
41048	41048-017	SHOE BRAKE		2			
41050	41050-018	CAM BRAKE		1			
41053	41053-005	LEVER BRAKE CAM		1			
41060	41060-014	GEAR METER SCREW, 10T		1			
41060A	41060-1026	GEAR METER SCREW		1			
41064	41064-010	RECEIVER SPEEDOMETER		1			
41068	41068-1108/00	AXLE 10X165		1			
41085	41085-013	INDICATOR BRAKE SHOE		1			
92015	41072-007	NUT 6MM		1			
92015A	42045-005	NUT 10MM		1			
92022	41063-001	WASHER 5.1X0.4		2			
92027	41039-002	COLLAR L=51		1			
92027A	41069-026	COLLAR L=13		1			
92028	41062-005	BUSHING SPEEDOMETER CABLE		1			
92043	41082-001	PIN SPRING		1			
92049	92050-002	SEAL OIL BRAKE PANEL		1			
92049A	92050-063	SEAL OIL TC 17317		1			
92055	92055-004	RING-O BRAKE CAM		1			
92081	92081-1766	SPRING BRAKE SHOE		2			
110	110G0630	BOL 6X30		1			
411	411B1000	WASHER PLAIN 10MM		1			
601	601B6200	BEARING BALL #6200C3		1			
601A	601B6300Z	BEARING BALL #6200ZC3		1			

This catalog covers:
 '96 AN80-G2 Chassis

GRID NO.

D-11

This grid covers:
 Rear Hub

F2240-0049

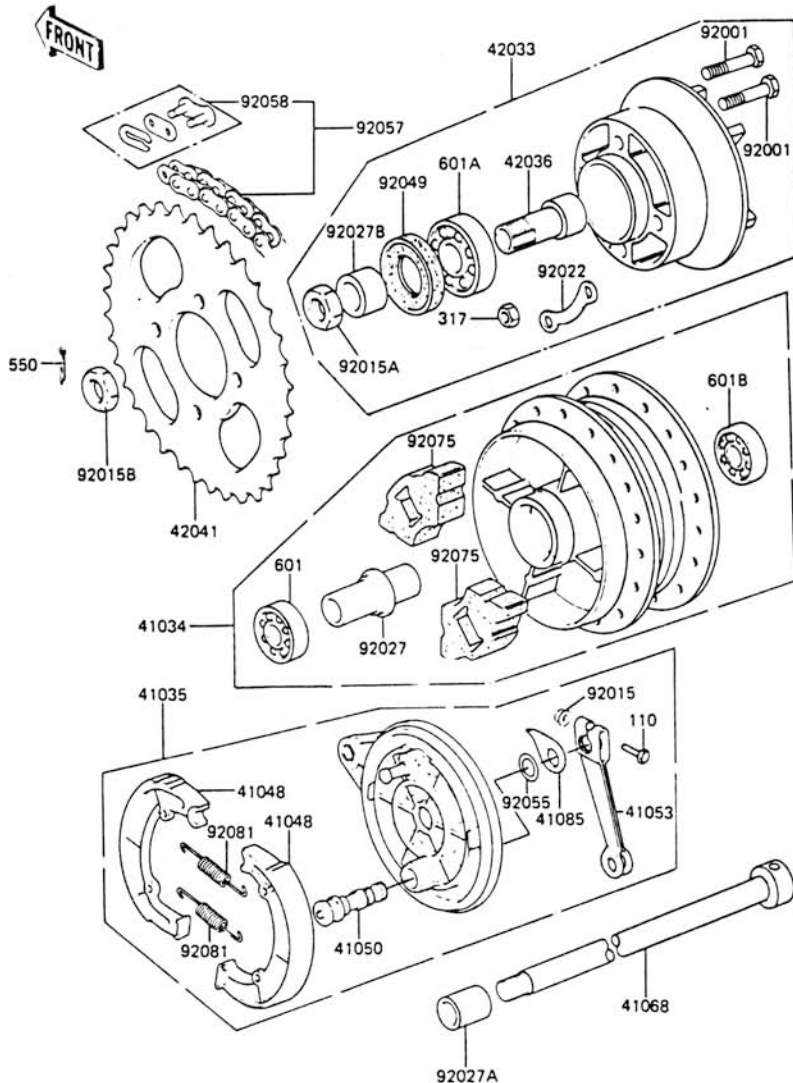

Ref. No.	Part No.	Description	Spec Code	Quantity - AN80			
				96			
41034	41034-1039	DRUM ASSY RR		1			
41035	41035-1467	PANEL ASSY BRAKE RR		1			
41048	41048-017	SHOE BRAKE		2			
41050	41050-012	CAM BRAKE		1			
41053	41053-002	LEVER BRAKE CAM		1			
41068	41068-1109	AXLE 12X215		1			
	41068-1109/00	AXLE 12X215/00 (OPTIONAL)		1			
41085	41085-003	INDICATOR BRAKE SHOE		1			
42033	42033-1026	COUPLING ASSY		1			
42036	42036-002	SLEEVE RR HUB COUPLING		1			
42041	42041-1065	SPROCKET HUN 39T		1			
92001	92001-021	BOLT 8X36		4			
92015	41072-007	NUT 6MM		1			
92015A	42045-004	NUT 16MM		1			
92015B	42045-005	NUT 10MM		1			
92022	92088-003	WASHER SPROCKET LOCK		2			
92027	42010-005	COLLAR L=58		1			
92027A	42032-002/00	COLLAR 12.2X22X30,5		1			
92027B	42037-003	COLLAR 17X25X12,5		1			
92049	92052-003	SEAL OIL COUPLING		1			
92055	92055-004	RING O BRAKE CAM		1			
92057	92057-1175	CHAIN DRIVE EK420MRX110L		1			
92058	92058-1056	JOINT CHAIN		1			
92075	42014-016	DAMPER RR HUB SHOCK		4			
92081	92081-1766	SPRING BRAKE SHOE		2			
110	110G0630	BOLT 6X30		1			
317	317B0800	NUT HEX SMALL 8MM		4			
550	550D3025	PIN COTTER 3,0X25		1			
601	601B6201Z	BEARING BALL #6201ZC3		1			
601A	601B6203	BEARING BALL #6203C3		1			
601B	601B6301Z	BEARING BALL #6301ZC3		1			

F2260-0047

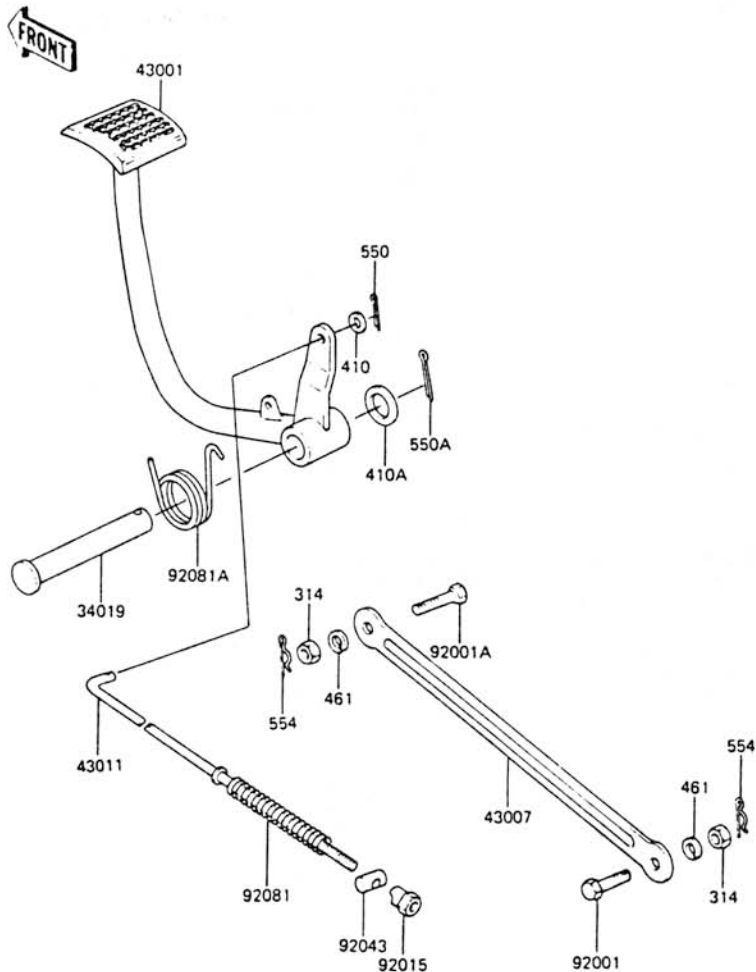

Ref. No.	Part No.	Description	Spec Code	Quantity - AN80			
				96			
34019	34019-008/00	SHAFT STAND CNT		1			
43001	43001-1155	LEVER BRAKE		1			
43007	43007-028/00	ROD TORQUE RR		1			
43011	43011-010	ROD BRAKE		1			
92001	92003-003	BOLT 10X32		1			
92001A	92003-017	BOLT 10X25		1			
92015	92015-042	NUT BRAKE ROD		1			
92043	92043-039	PIN BRAKE ROD		1			
92081	43012-001/00	SPRING BRAKE ROD		1			
92081A	92081-1332/00	SPRING BRAKE PEDAL		1			
314	314B1000	NUT HEX FINE 10MM		2			
410	410B0600	WASHER PLAIN SMALL 6MM		1			
410A	410B1400	WASHER PLAIN SMALL 14MM		1			
461	461F1000	WASHER SPRING 10 MM		2			
550	550D2015/00	PIN COTTER 2.0X15		1			
550A	550D3030	PIN COTTER 3.0X30		1			
554	554A0800	PIN SNAP 8MM		2			

F2301-0216

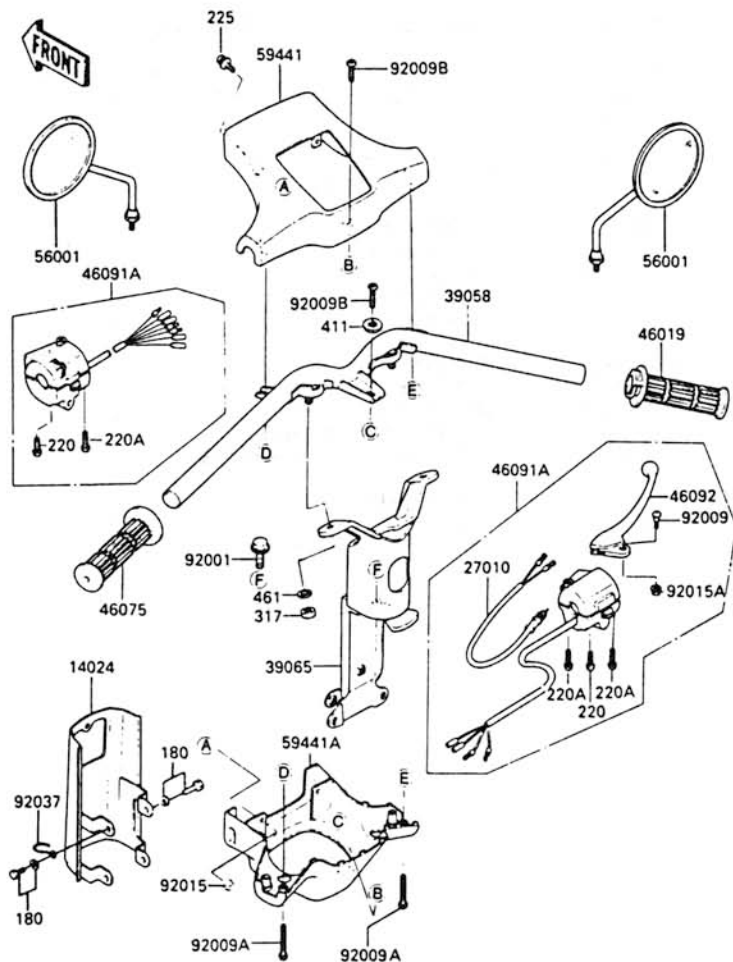

Ref. No.	Part No.	Description	Spec Code	Quantity - AN80			
				96			
14024	14025-1293/00	COVER		1			
27010	21008-1051	SWITCH, BRAKE		1			
39058	39058-1051/00	HANDLE-COMP		1			
39065	39065-1051/00	HOLDER-COMP-HANDLE		1			
46019	46019-1014	GRIP-ASSY, THROTTLE		1			
46075	46075-1018	GRIP, LH		1			
46091	46091-1339	HOUSING-ASSY-CONTROL, LH		1			
46091A	46091-1340	HOUSING-ASSY-CONTROL, RH		1			
46092	46092-1013	LEVER-GRIP, FRONT BRAKE		1			
56001	56001-1203	MIRROR-ASSY		2			
59441	59441-1051	COVER-HANDLE		1			
59441A	59441-1052	COVER-HANDLE		1			
92001	92001-1153	BOLT, 10X25		1			
92009	92009-1152	SCREW, GRIP LEVER		1			
92009A	92009-1263	SCREW, TAPPING, 5X40		4			
92009B	92009-1264	SCREW, TAPPING, 5X16		2			
92015	92015-1317	NUT, FLANGED, 4MM		2			
92015A	92019-014	NUT, LOCK, 5MM		1			
92037	92037-1295	CLAMP		1			
180	180B0612	BOLT-UPSET-WS, 6X12		4			
220	220B0525	SCREW-PAN-CROS, 5X25		2			
220A	220B0530	SCREW-PAN-CROS		4			
225	225B0412	SCREW-PAN-WSP-CROS		2			
317	317B0800	NUT-HEX-SMALL, 8MM		2			
411	411B0500	WASHER-PLAIN, 5MM		1			
461	461F0800	WASHER-SPRING, 8MM		2			

F2340-0067

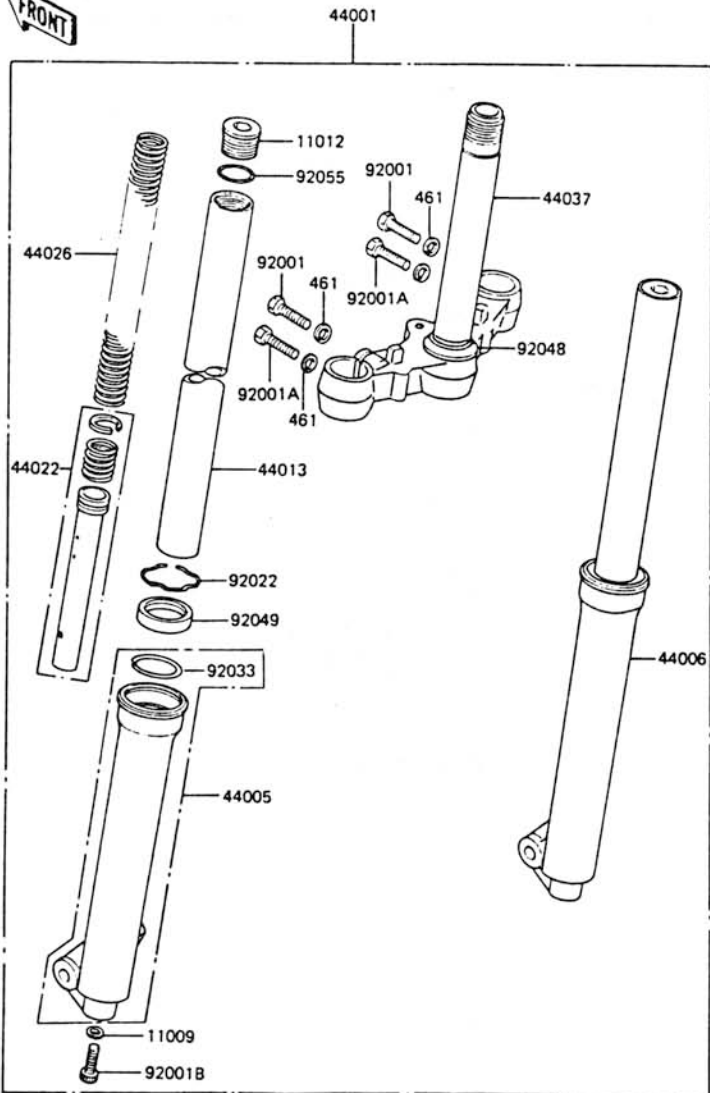

Ref. No.	Part No.	Description	Spec Code	Quantity - AN80			
				96			
11009	44045-051	GASKET, FORK CYLINDER BOLT		2			
11012	11012-1173	CAP, FORK BOLT		2			
44001	44001-1382	FORK-FRONT		1			
44005	44005-1105	PIPE-LEFT FORK OUTER		1			
44006	44006-1105	PIPE-RIGHT FORK OUTER		1			
44013	44013-1056	PIPE-FORK INNER		2			
44022	44022-1053	CYLINDER-FORK		2			
44026	44026-1101	SPRING-FRONT FORK		2			
44037	44037-1061	HOLDER-FORK UNDER		1			
92001	92001-1435	BOLT-1435		2			
92001A	92001-1446	BOLT, 8X30		2			
92001B	92001-1464	BOLT, FORK CYLINDER		2			
92022	92022-1253	WASHER, OUTER PIPE		2			
92033	92033-1087	RING-SNAP, OUTER PIPE		2			
92048	92047-013	RACE, STEERING STEM BEARING		1			
92049	92049-1071	SEAL-OIL, OUTER PIPE		2			
92055	92055-1104	RING-O, FRONT FORK		2			
461	461F0800	WASHER-SPRING, 8MM		4			

This catalog covers:
'96 AN80-G2 Chassis

GRID NO.

E-3

This grid covers:
Fuel Tank

F2410-0203

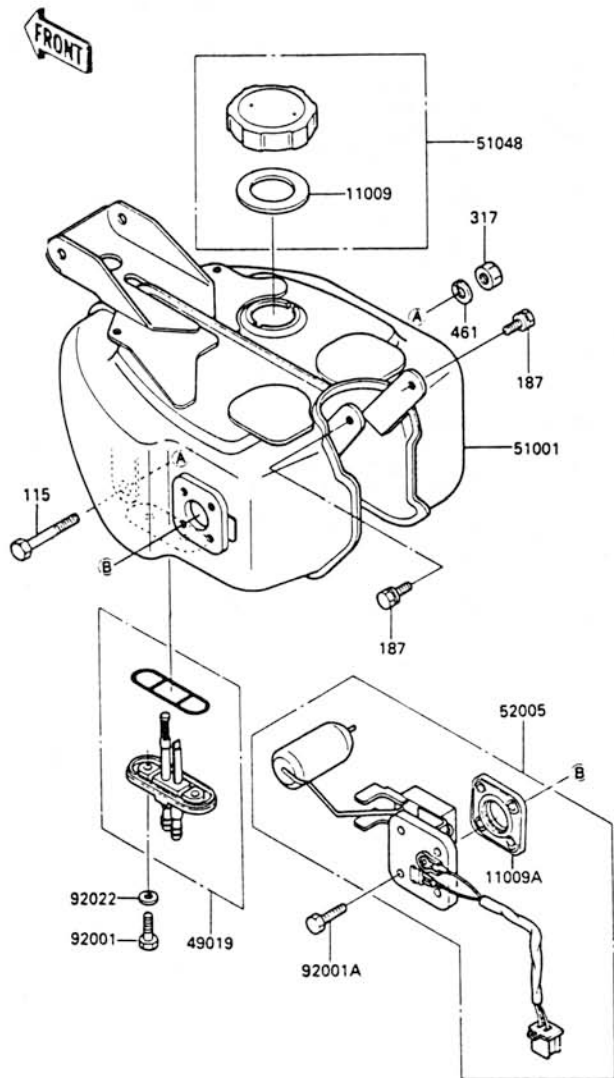

Ref. No.	Part No.	Description	Spec Code	Quantity - AN80			
				96			
11009	11009-1326	GASKET, TANK CAP		1			
11009A	11009-1656	GASKET, FUEL GAUGE		1			
49019	49019-1051	FILTER-FUEL		1			
51001	51001-1153	TANK-COMP-FUEL		1			
51048	51048-1052	CAP-ASSY-TANK		1			
52005	52005-1080	GAUCE, FUEL		1			
92001	92001-114	BOLT, 6X16		2			
92001A	92001-1705	BOLT, FUEL GAUCE		4			
92022	92022-183	WASHER, 6.2X11X1.5		2			
115	115B0855	BOLT-SMALL-UPSET		1			
187	187B0612	BOLT-UPSET-WSP		2			
317	317B0800	NUT-HEX-SMALL, 8MM		1			
461	461F0800	WASHER-SPRING, 8MM		1			

GRID NO.

E-4

This grid covers:

Seat

This grid covers:

'96 AN80-G2 Chassis

F2510-0232

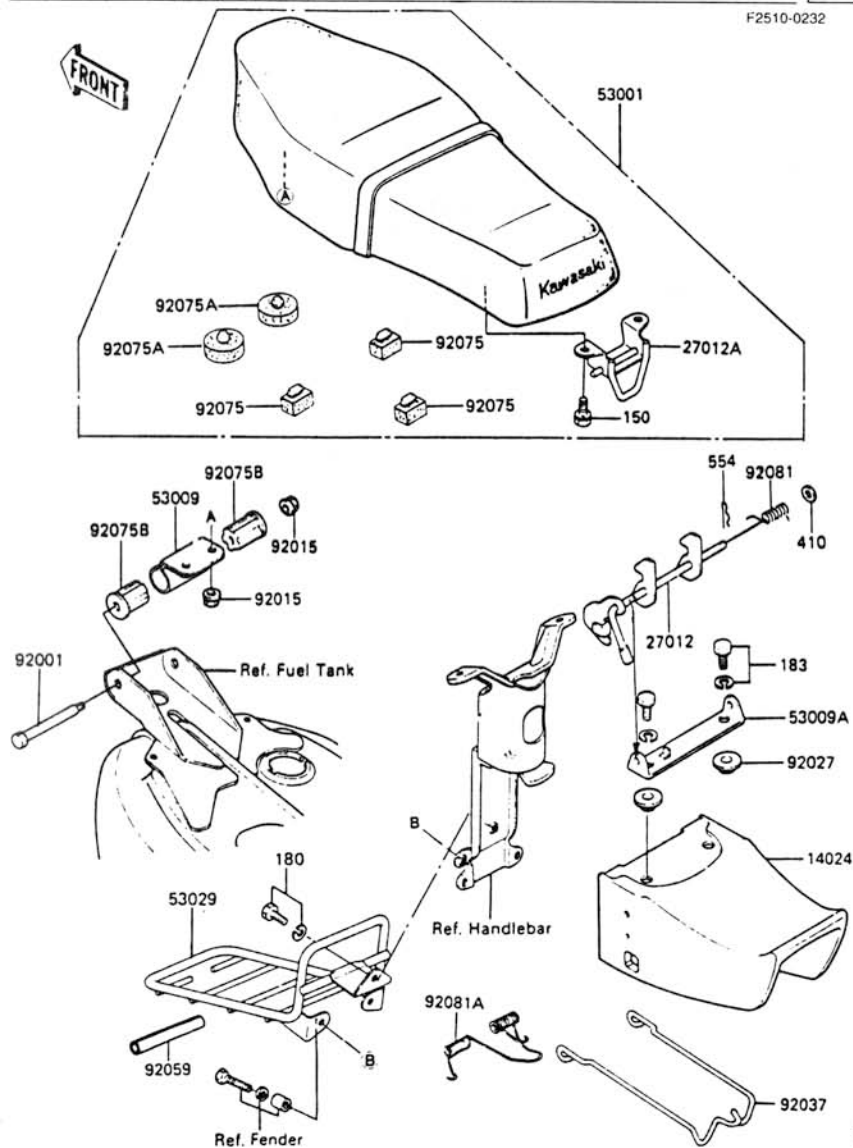

Ref. No.	Part No.	Description	Spec Code	Quantity - AN80				
				96				
14024	14025-1294	COVER, SEAT		1				
27012	27012-1020	HOOK, SEAT		1				
27012A	27012-1305	HOOK, SEAT		1				
53001	53001-1359/00	SEAT-ASSY, DUAL		1				
53009	53009-1025	HINGE, SEAT, FRONT		1				
53009A	53009-1027	HINGE, SEAT, REAR		1				
53029	53029-1031/00	CARRIER, FR		1				
92001	92001-1417	BOLT, 6X72.5		1				
92015	92015-1078	NUT, FLANGED, 6MM		3				
92027	92027-1354	COLLAR		2				
92037	92037-1400	CLAMP, CARRIER		1				
92059	92059-1514	TUBE, 5X8X87		2				
92075	92075-099	DAMPER		3				
92075A	92075-1288	DAMPER		2				
92075B	92075-1289	DAMPER		2				
92081	92081-1356	SPRING, SEAT HOOK		1				
92081A	92081-1569	SPRING, CARRIER CLAMP		1				
150	150B0612	BOLT-WS		2				
180	180B0614	BOLT-UPSET-WS		1				
183	183B0620	BOLT-UPSET-WS-SMALL		2				
410	410B0600	WASHER-PLAIN-SMALL, 6MM		1				
554	554A0600	PIN-SNAP		1				
	ZCANA-AN-80			1				N.I.

F2530-0233



25001

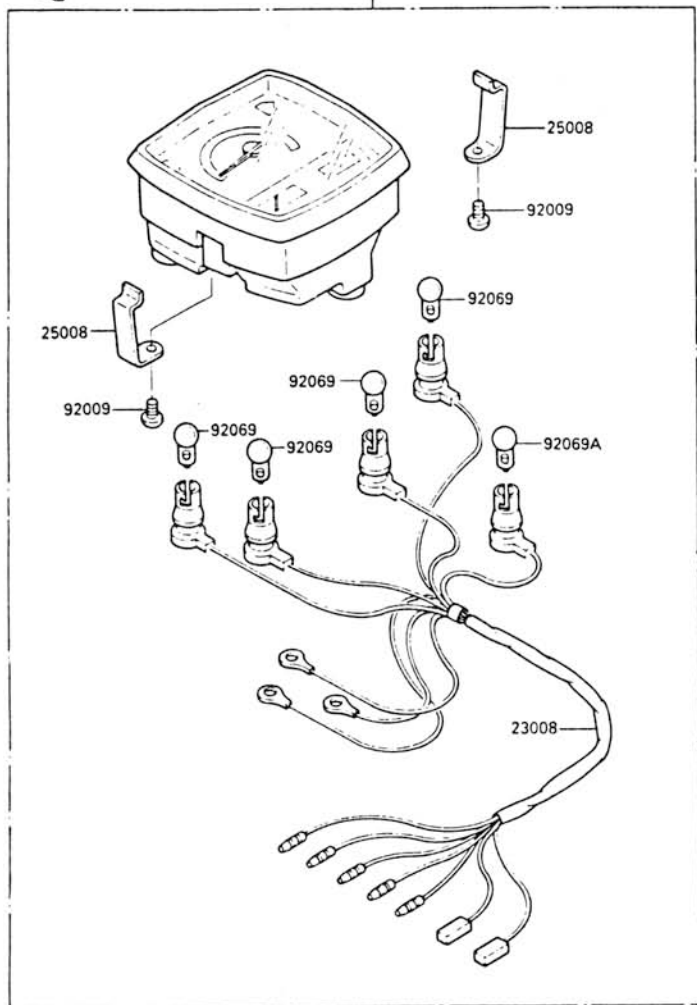

Ref. No.	Part No.	Description	Spec Code	Quantity - AN80				
				96				
23008	23008-1210	SOCKET ASSY		1				
25001	25001-1934	METER ASSY KPH		1				
25008	25008-1105	BRACKET METER		2				
92009	92009-1254	SCREW TAPPING 4X12		2				
92069	92069-017	BULB 12V 1.7 W		4				
92069A	92069-018	BULB 12V 3.4W		1				

This catalog covers:
'96 AN80-G2 Chassis

GRID NO.

E-6

This grid covers:
Cable

F2540-0199

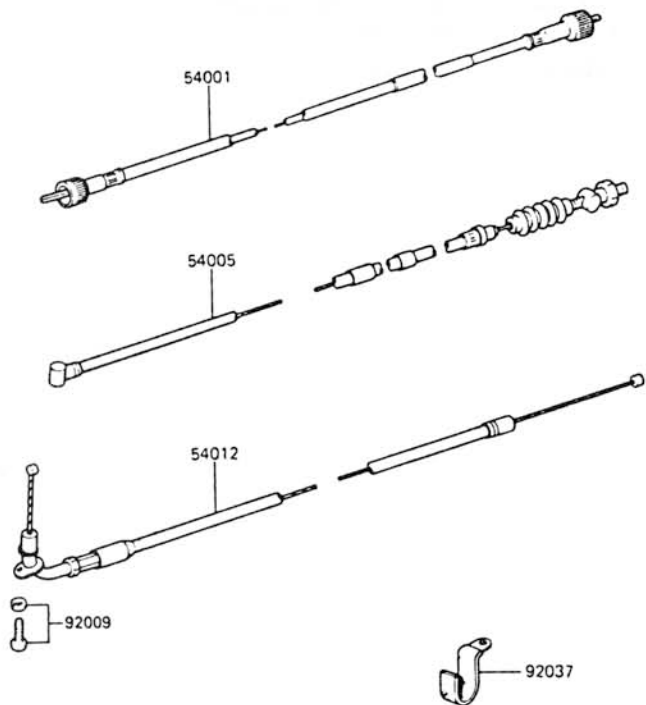

Ref. No.	Part No.	Description	Spec Code	Quantity - AN80				
				96				

54001	54001-1032	CABLE SPEEDOMETER		1				
54005	54005-1034	CABLE BRAKE		1				
54012	54012-1224	CABLE THROTTLE		1				
92009	92009-1331	SCREW 5X10		1				
92037	92037-1316	CLAMP HARNESS		1				

This catalog covers:
'96 AN80-G2 Chassis

GHID NO.

E-7

This grid covers:
Side Cover/Chain Case

F2610-0238

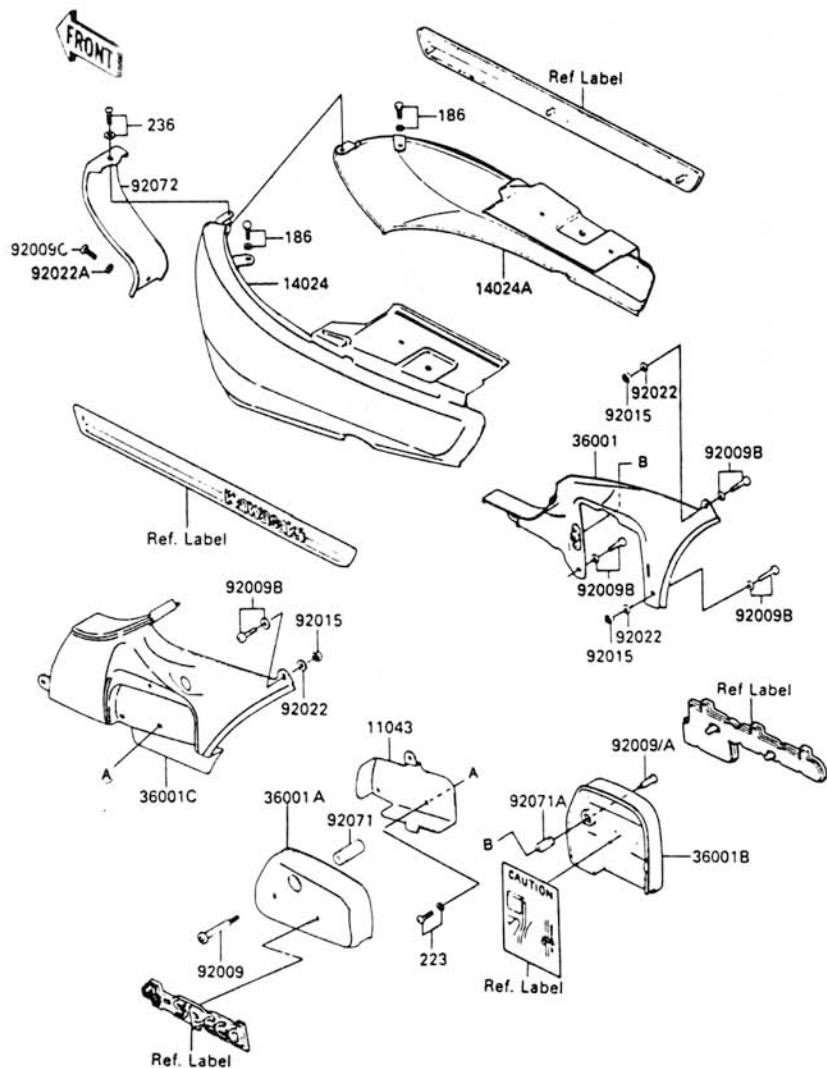

Ref. No.	Part No.	Description	Spec Code	Quantity - AN80			
				96			
11043	11043-1339	BRACKET, SIDE COVER		1			
14024	14025-1860	COVER, LH FRAME		1			
14024A	14025-1861	COVER, RH FRAME		1			
36001	36001-1120	COVER-SIDE, RH		1			
36001A	36001-1131	COVER-SIDE, TOOL		1			
36001B	36001-1162/00	COVER-SIDE, RH		1			
36001C	36001-1253	COVER-SIDE		1			
92009	92009-1091	SCREW, 6X40		1			
92009A	92009-1136	SCREW, 6X79.5		1			
92009B	92009-1273	SCREW, W/P, 6X16		4			
92009C	92009-1298	SCREW, 6X20		1			
92015	92019-008	NUT, LOCK, 6MM		3			
92022	92022-024	WASHER, 7X16X1.2		3			
92022A	92022-1143	WASHER, 6.5X16X1		1			
92071	92071-1001	GROMMET, SIDE COVER		1			
92071A	92071-1040	GROMMET, SIDE COVER		1			
92072	92072-1061	BAND, FRAME COVER		1			
186	186B0612	BOLT-UPSET-WP		4			
223	223B0614	SCREW-PAN-WS-CROS		2			
236	236B0614	SCREW-PAN-WSP-CROS		1			

F2640-0004

Ref. No.	Part No.	Description	Spec Code	Quantity - AN80			
				96			
36014	36014-1105/00	CASE-CHAIN, UPP		1			
36014A	36014-1106/00	CASE-CHAIN, LWR		1			
55028	55028-1055	COWLING		1			
92022	92022-165	WASHER, PLAIN, 6MM		4			
92066	92074-004	PLUG, CHAIN CASE, 34X1		1			
92072	92072-1052	BAND, LEG SHIELD		1			
187	187B0612	BOLT-UPSET-WSP		2			
187A	187B0614	BOLT-UPSET-WSP		2			
220	220E0620	SCREW-PAN-CROS, 6X20		6			
224	224B0628	SCREW-PAN-WP-CROS		1			
311	311B0600	NUT-HEX, 6MM		1			
411	411B0600	WASHER-PLAIN, 6MM		3			
461	461F0600	WASHER-SPRING, 6MM		3			

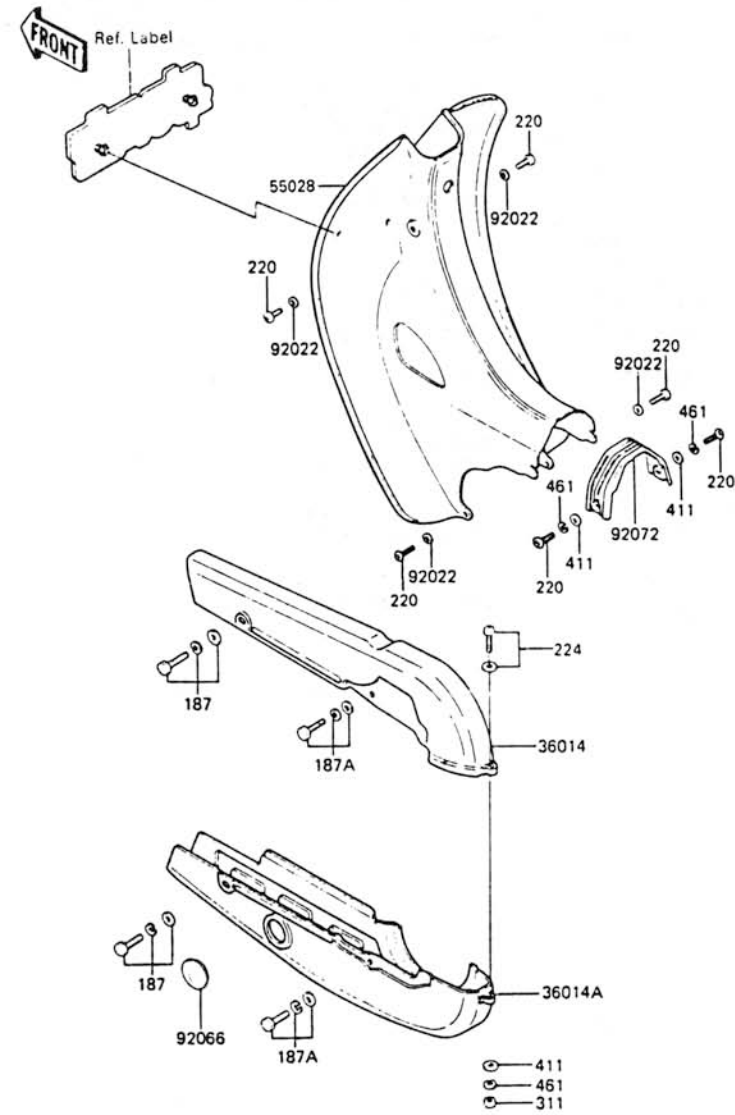

This catalog covers:
 '96 AN80-G2 Chassis

GRID NO.

E-9

This grid covers:
Head Lamp

F2710-0213

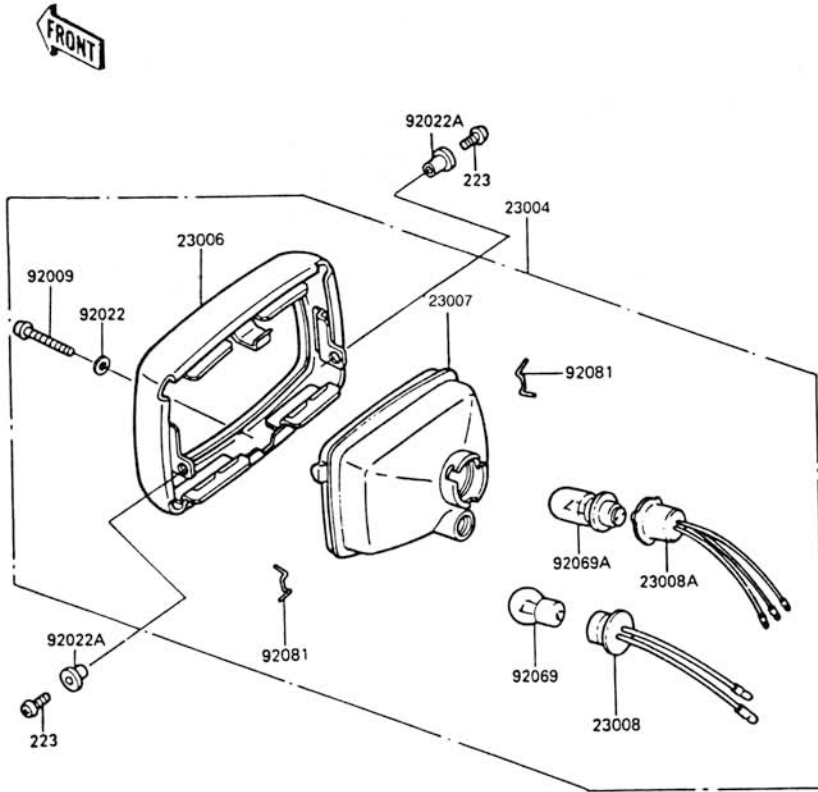

Ref. No.	Part No.	Description	Spec Code	Quantity - AN80			
				96			
23004	23004-1162	LAMP-HEAD		1			
23006	23006-1052	RIN-LAMP		1			
23007	23007-1160	LENS-COMP, "110-40885" MARK		1			
23008	23008-1070	SOCKET-ASSY, LAMP		1			
23008A	23008-1145	SOCHET-ASSY, HEAD LAMP		1			
92009	92009-1139	SCREW, 4X30		1			
92022	23021-008	WASHER, FOCUS ADJUSTIN		1			
92022A	23021-010	WHASER		2			
92069	92069-018	BULB, 12V 3.4W		1			
92069A	92069-1010	BULB, 12V 25/25W		1			
92081	92081-1334	SPRING, LAMP RIN		2			
223	223B0514	SCREW-PAN-WS-CROS		2			

F2720-0172



Ref. No.	Part No.	Description	Spec Code	Quantity - AN80			
				96			

11009	11009-1215	GASKET, TAIL LAMP		1			
23025	23025-1042	LAMP-TAIL		1			
23026	23026-1019	LENS, TAIL LAMP		1			
23027	23027-1023	BODY-COMP-TAIL LAMP		1			
23036	23036-1040	BRACKET-TAIL LAMP		1			
92009	92009-1069	SCREW, TAPPING, 4X25		2			
92069	92069-1011	BULB, 12V20/5W		1			
180	180B0612	BOLT-UPSET-WS, 6X12		2			
187	187B0616	BOLT-UPSET-WSP		3			

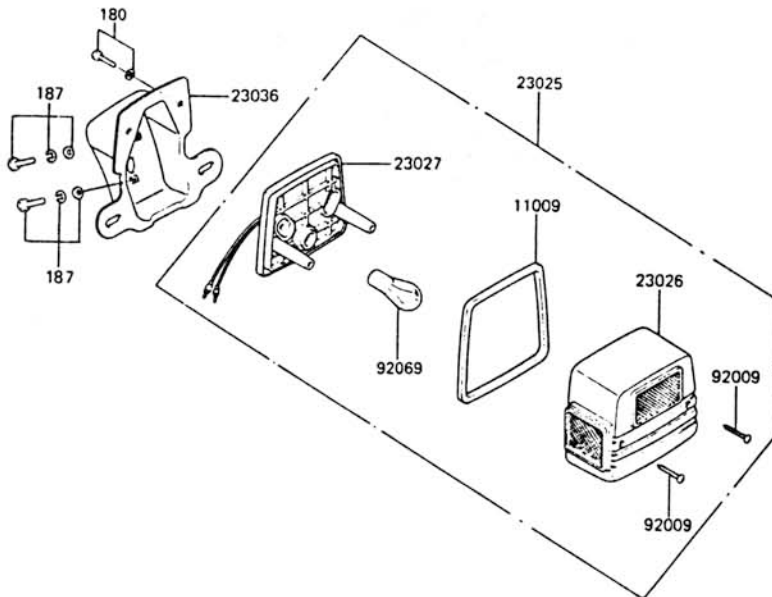

F2730-0130

Ref. No.	Part No.	Description	Spec Code	Quantity - AN80			
				96			
23037	23037-1123/00	LAMP-ASSY-SIGNAL, FRONT		2			
23037A	23037-1248/00	LAMP-ASSY-SIGNAL., RR		2			
23048	23048-1018	LENS-SIGNAL LAMP		4			
92009	92009-1056	SCREW, TAPPING, 4X30		8			
92069	92069-085	BULB, 12V 10W		4			
223	223B0616	SCREW-PAN-WS-CROS, 6X16		2			
314	314B1000	NUT-HEX-FINE, 10MM		2			
461	461F1000	WHASER-SPRING, 10MM		2			

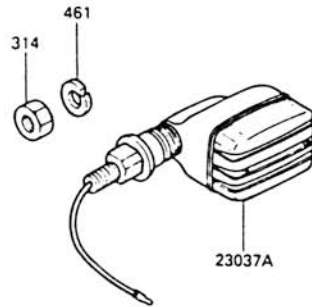
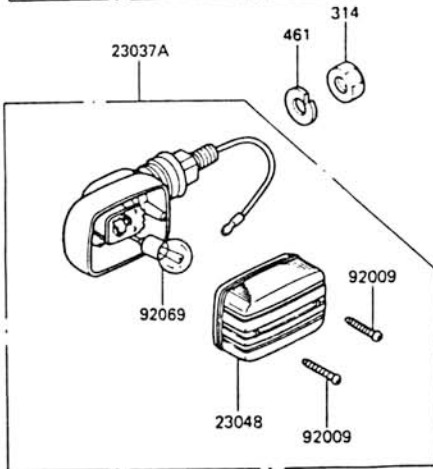
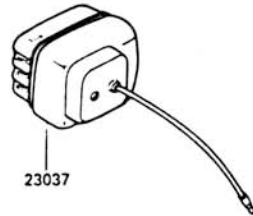
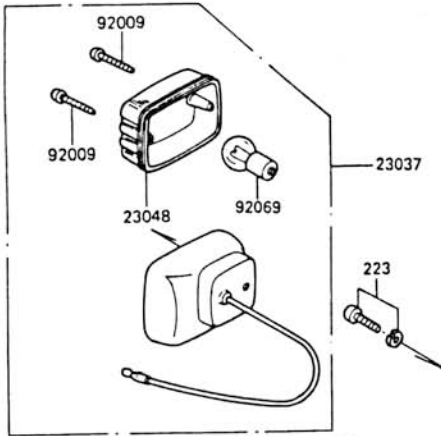

F2760-0281

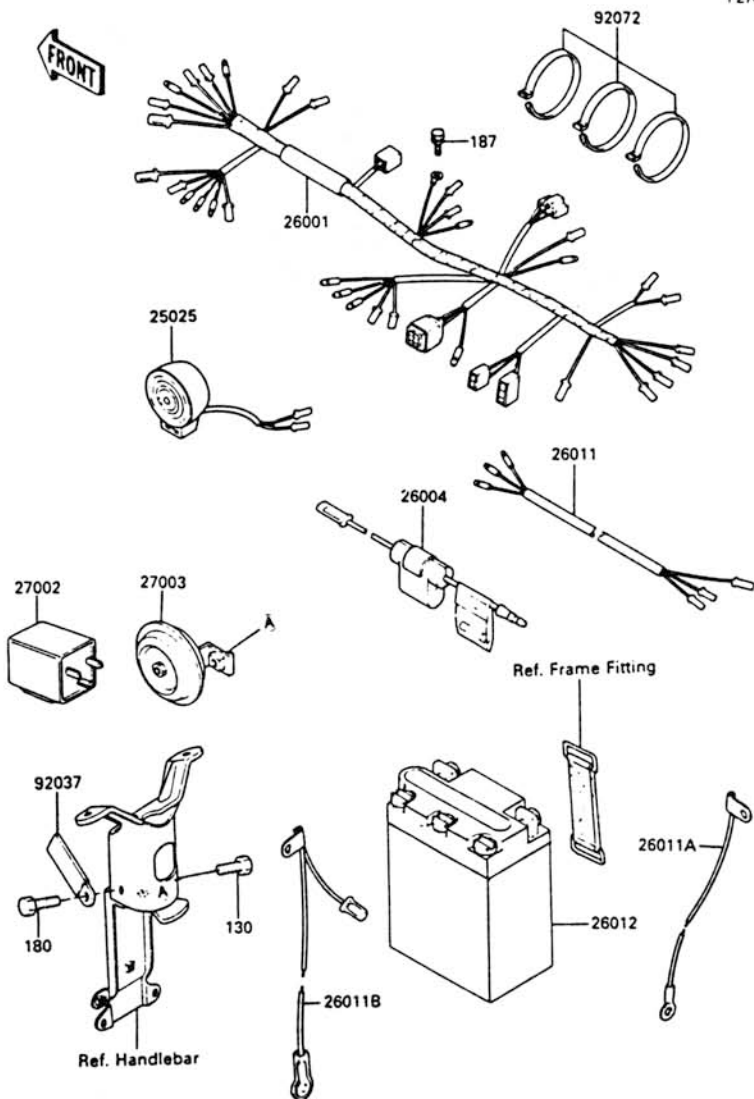

Ref. No.	Part No.	Description	Spec Code	Quantity - AN80			
				96			
25025	25025-1001	WARNER				1	
26001	26001-1577/00	HARNES MAIN				1	
26004	26004-026	FUSE ASSY				1	
26011	26011-1123	WIRE LEAD				1	
26011A	26011-1149	WIRE LEAD L=380 (-)				1	
26011B	26011-1150	WIRE LEAD L=480 (+)				1	
26012	26012-1064	BATTERY 12N5.5A - 3B				1	
27002	27002-1057	RELAY ASSY TURN SIGNAL				1	
27003	27003-1063	HORN 12V 1.5A				1	
92037	92037-1069	CLAMP WIRING HARNES				1	
92072	92072-032	BAND, L=218				3	
130	130D0612	BOLT-FLANGED				1	
180	180B0612	BOLT-UPSET-WS, 6X12				1	
187	187B0614	BOLT-UPSET-WSP				1	

This catalog covers:
 '96 AN80-G2 Chassis

GRID NO.

E-13

This grid covers:
Ignition Switch

F2770-0228

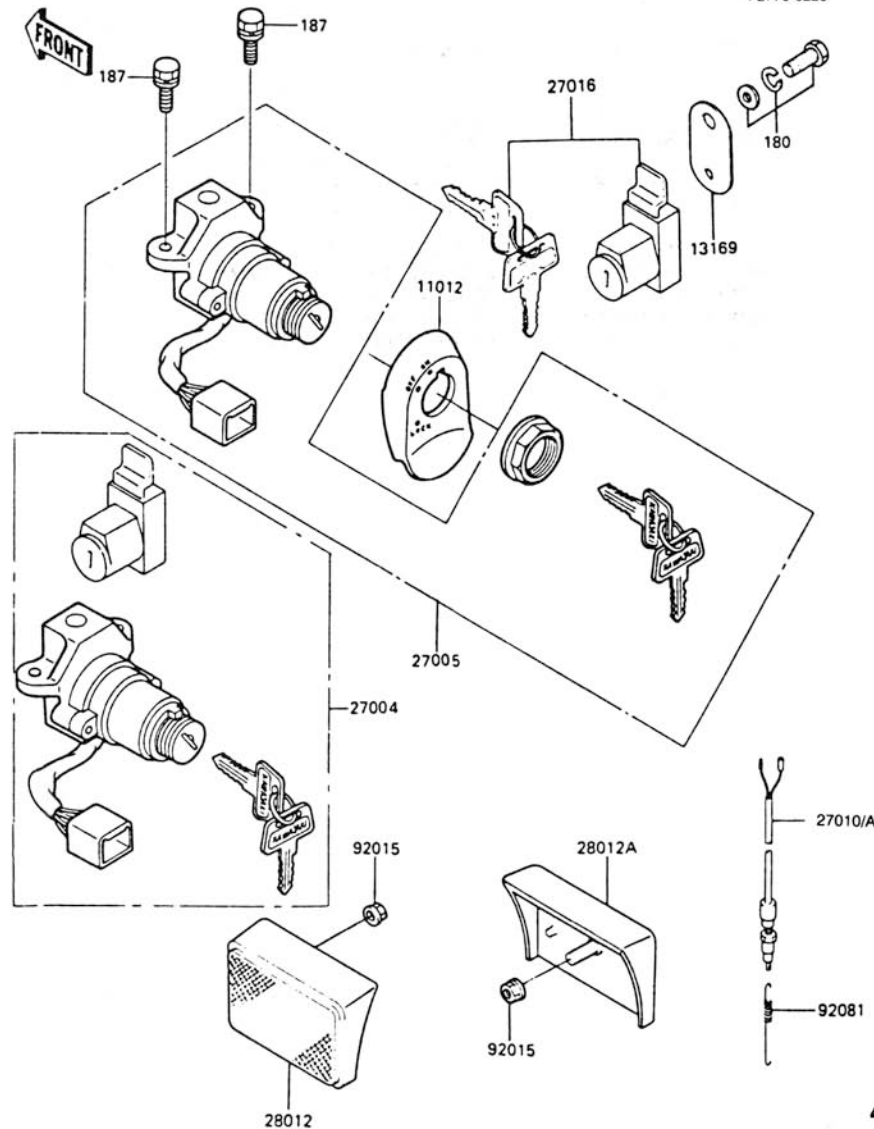

Ref. No.	Part No.	Description	Spec Code	Quantity - AN80			
				96			
11012	11012-1364	CAP		1			
13169	13169-1468	PLATE, SEAT LOCK		1			
27004	27004-5215	SWITCH-ASSY		1			
27005	27005-1101	SWITCH-ASSY-IGNITION		1			
27010A	27010-1019	SWITCH, REAR BRAKE		1			
27016	27016-5046	LOCK-ASSY, SEAT		1			
28012	28012-1007	REFLECTOR-REFLEX, LH		1			
28012A	28012-1008	REFLECTOR-REFLEX, RH		1			
92015	92015-1259	NUT-FLANGED, 5MM		2			
92081	27011-014	SPRING-SWITCH		1			
180	180B0614	BOLT-UPSET-WS					
187	187G0616	BOLT-UPSET-WSP					

This catalog covers:
'96 AN80-G2 Chassis

GRID NO.

E-14

This grid covers:

Tool

F2810-0045

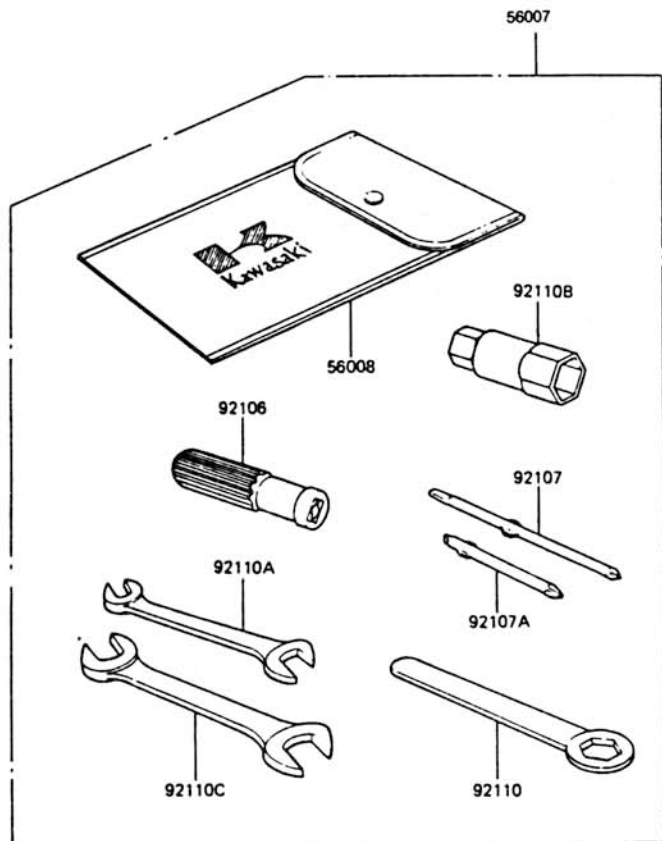

Ref. No.	Part No.	Description	Spec Code	Quantity - AN80				
				96				
56007	56007-1297	TOOL KIT		1				
56008	56008-1007	BAG, TOOLL		1				
92104	92104-002	GASKET LIQUID, TUBE, 100G		1				
92106	92106-1001	GRIP-SCREW DRIVER		1				
92107	92107-003	TOOLL - DRIVER #2 PHILLIPS & LOT		1				
92107A	92107-005	TOOL DRIVER #3 PHILLIPS		1				
92110	92110-1024	TOOL WRENCH BOX EN 22MM		1				
92110A	92110-1038	TOOL WRENCH OPEN END 10X12		1				
92110B	92110-1102	TOOL WRENCH BOX 16MM		1				
92110C	92163-003	TOOL WRENCH OPEN END 14X17		1				

This catalog covers:
 '96 AN80-G2 Chassis

GRID NO.

F-3

This grid covers:

Label

F2860-0243

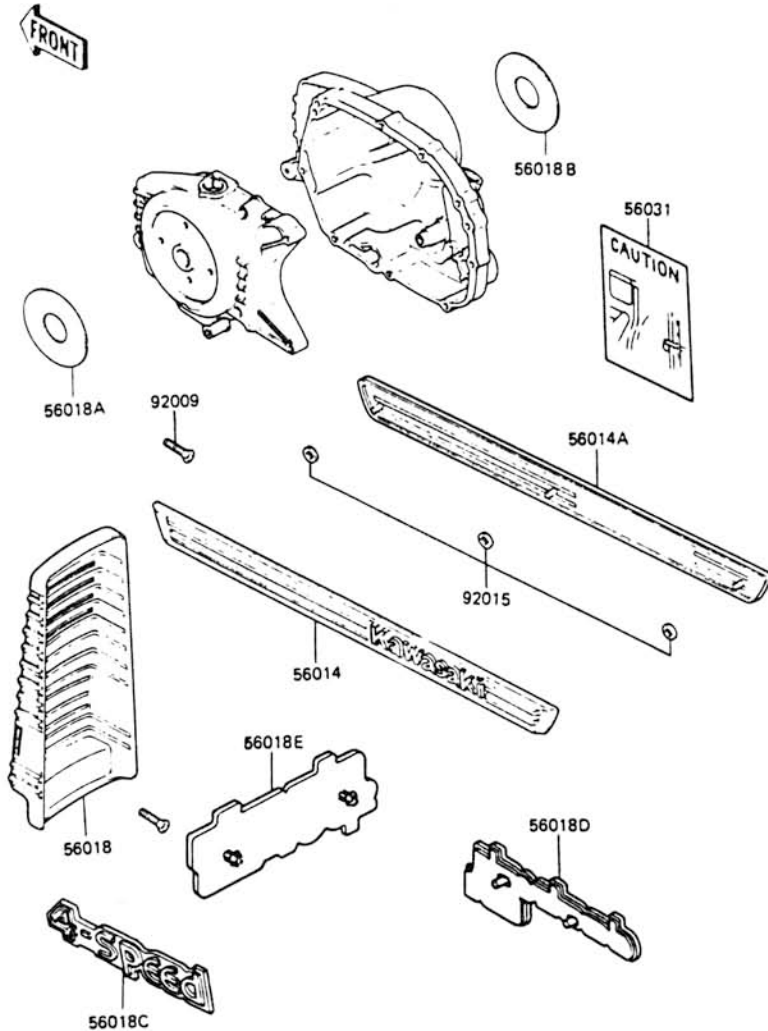

Ref. No.	Part No.	Description	Spec Code	Quantity - AN80				
				96				
56014	56014-1054	EMBLEM, LH FRAME COVER		2				
56014A	56014-1055	EMBLEM, RH FRAME COVER		1				
56018	56018-1280	MARK, FRONT FORK		1				
56018A	56018-1397	MARK, ENGINE COVER		1				
56018B	56018-1398	MARK, CLUTCH COVER		1				
56018C	56018-1477	MARK, SIDE COVER, LH		1				
56018D	56018-1478	MARK, SIDE COVER, RH		1				
56018E	56018-1479	MARK, LEG SHIELD		1				
56018F	56018-1479-K/00	EMBLEMA "K" FLOTANTE		1				N.I.
56031	56031-1143	LABEL-MANUAL, BATTERY VENT HOSE		1				
92009	92008-009	SCREW, TAPPING, 3X10		2				
92015	92018-005	NUT, PUSH, 3MM		6				

NUMERICAL PARTS INDEX AN-80

Part No.	Grid. No.
11004-1293	B-3
11005-1593	B-4
11008-1078	B-3
11009-1215	E-10
11009-1283	C-5
11009-1326	E-3
11009-1332	C-3
11009-1344	C-3
11009-1347	B-3
11009-1405	C-5
11009-1527	C-6
11009-1528	C-6
11009-1656	E-3
11011-1072	B-5
11012-1157	B-5
11012-1173	D-14
11012-1294	B-11
11012-1303	B-3
11012-1354	C-10
11012-1364	E-13
11012-1387	C-5
11012-1395	C-4
11013-1044	B-5
11013-1046	B-5
11043-1339	E-7
11060-1488	B-6
11060-1500	B-8
11060-1506	B-4
11060-1536	C-4
11060-1584	C-4
11060-1595	C-4
110G0630	D-10
110G0630	D-11
112C1030	D-8
112G0610	B-8
113B1245	D-5
115B0855	E-3
12004-1060	B-7
12005-1056	B-7
12009-1052	B-7
12011-1002	B-7

Part No.	Grid. No.
12016-1003	B-7
12020-1009	B-7
12046-1035	B-8
12046-1060	B-9
12049-1059	B-8
12053-1086	B-8
12053-1106	B-8
13001-1084	B-4
13002-1061	B-4
13008-1062	B-4
13024-1016	B-4
13025-1016	B-4
13027-1037	B-4
13029-1038	B-4
13031-1164	B-9
13034-1030	B-9
13035-1051	B-9
13037-1107	B-9
13037-5031	B-9
13044-5032	B-9
13063-002	B-10
13064-1042/00	B-10
13064-1046	B-10
13066-1017	B-10
13070-1035	B-10
13070 1046	C-3
13078-1052	B-10
13081-1323	B-11
13086-1054	B-11
13088-1012	B-11
13089-1006	B-11
13089-1061	B-11
13089-1090	B-11
13096-1018	B-11
13097-1081	B-9
130D0612	E-12
130Y0616	B-8
130Y0620	B-3
130Y0625	B-8
13102-1073	B-11
13107-1027	C-10

Part No.	Grid. No.
13114-1054	B-11
13116-1105	B-8
13119-1056	B-11
13127-1124	B-12
13128-1034	B-12
13129-1270	B-12
13129-1274	B-12
13129-1614	B-12
13129-1618	B-12
13129-1619	B-12
13140-1110	B-13
13140-1118	B-13
13140-1119	B-13
13144-1043	B-12
13144-1044	B-12
13144-1045	B-12
13151-1008	C-3
13161-1047	B-14
13168-1109	B-14
13168-1227	C-5
13168-1271	C-6
13168-1272	C-6
13169-1468	E-13
13169-1809	C-6
13169-1947	C-6
13169-1949	C-6
13193-1010	C-10
131G08105	D-4
131G08110	D-4
131G0875	D-4
13206-1006	B-10
13216-1028	C-10
13216-1039	B-11
13236-1058	B-14
13239-1052	B-13
13242-1079	B-14
13260-1045	B-12
13260-1320	B-12
14002-1334	C-3
14002-1341	C-3
14014-1026	B-14

Part No.	Grid. No.
14020-1058	B-8
14020-1092	B-11
14025-1291	D-7
14025-1292	D-7
14025-1293/00	D-13
14025-1294	E-4
14025-1677	C-4
14025-1692	B-3
14025-1788	D-5
14025-1860	E-7
14025-1861	E-7
14025-1872	C-4
14026-1106	C-4
14031-1157	C-4
14032-1115	C-4
14073-1157	B-5
14073-1163	B-5
15001-1447	C-5
15001-1532	C-6
150B0612	E-4
16002-004	C-6
16002-1010	C-5
16003-004	C-6
16004-1014	C-5
16004-1057	C-6
16007-1109	B-7
16007-1110	C-5
16007-1116	C-6
16009-1221	C-5
16009-1536	C-6
16012-019	C-6
16012-1053	C-5
16014-1020	C-6
16014-1022	C-5
16016-1002	C-6
16016-1053	C-5
16017-1221	C-5
16017-1289	C-6
16021-1107	C-5
16021-1113	C-6
16025-1108	C-5

Part No.	Grid. No.
16025-1121	C-6
16030-1054	C-5
16030-1061	C-6
16031-1019	C-5
16031-1061	C-6
16038-022	C-6
16038-024	C-6
16039-015	C-6
16060-1065	B-3
16073-1060	B-3
16082-1052	C-7
16085-1114	B-9
16097-1051	C-7
16115-1013	C-4
18001-1537	B-6
180B0612	D-13
180B0612	E-10
180B0612	E-12
180B0614	E-4
180B0614	E-13
180B0616	D-4
180B0622	D-7
183B0818	D-6
183B0820	D-4
183B0820	E-4
186B0612	E-7
187B0612	E-3
187B0612	E-8
187B0614	E-8
187B0614	E-12
187B0616	D-7
187B0616	E-10
187G0616	E-13
21003-1063	C-8
21008-1051	D-13
21027-004	C-10
21047-1024	C-8
21049-1017	C-8
21050-1101	C-8
21066-1023	C-8
21119-1112	C-8

NUMERICAL PARTS INDEX AN-80

Part No.	Grid. No.
21121-1061	C-9
21130-1003	C-9
21132-005	C-9
21152-1001	C-8
21163-1083	C-10
21163-1083-AC	C-10
220B01512	B-11
220B0306	C-5
220B0306	C-6
220B0514	C-8
220B0516	C-9
220B0525	D-13
220B0530	D-13
220B0614	B-14
220B0614	B-7
220B0614	C-3
220B0616	C-4
220B0625	B-8
220B0625	C-10
220B0625	C-7
220B0630	C-7
220B0630	C-8
220B0640	C-10
220E0620	E-8
220X0612	C-3
220X0620	B-3
220X0630	C-4
220X0635	C-3
220X0635	C-4
220X0640	C-4
220X0675	C-3
220X0675	C-4
221B0510	C-4
223B0412	C-5
223B0412	C-6
223B0414	C-6
223B0514	E-9
223B0614	E-7
223B0616	E-11
223D0406	C-10
223D0516	C-10

Part No.	Grid. No.
224B0614	B-5
224B0628	E-8
225B0412	D-13
225B0612	D-5
23004-1162	E-9
23006-1052	E-9
23007-1160	E-9
23008-1070	E-9
23008-1145	E-9
23008-1210	E-5
23021-008	E-9
23021-010	E-9
23025-1042	E-10
23026-1019	E-10
23027-1023	E-10
23036-1040	E-10
23037-1123/00	E-11
23037-1248/00	E-11
23048-1018	E-11
236B0614	E-7
25001-1934	E-5
25008-1105	E-5
25025-1001	E-12
26001-1577/00	E-12
26004-026	E-12
26011-1123	E-12
26011-1149	E-12
26011-1150	E-12
26011-1272	C-10
26012-1064	E-12
27002-1057	E-12
27003-1063	E-12
27004-5215	E-13
27005-1101	E-13
27010-1019	E-13
27010-1075	C-10
27011-014	E-13
27012-1020	E-4
27012-1305	E-4
27016-5046	E-13
28012-1007	E-13

Part No.	Grid. No.
28012-1008	E-13
311B0600	D-5
311B0600	D-7
311B0600	E-8
314B1000	D-12
314B1000	E-11
314B1200	D-5
315B1400	B-9
315C1000	D-8
317B0800	D-11
317B0800	D-13
317B0800	D-4
317B0800	E-3
32002-1673	D-3
32032-1516	C-3
32033-1166	C-3
32069-1215	B-6
32069-1215/00	B-6
32069-1224	B-6
32069-1224/00	B-6
32085-1129	B-7
32098-1052	D-4
32109-1104/00	D-4
322B0600	B-3
33001-1099	D-5
33032-1018/00	D-5
33040-008	D-5
33040-010	D-5
34003-1205/00	D-6
34011-1056/00	D-8
34019-008/00	D-12
34024-1063/00	D-8
34025-005/00	D-8
34025-008/00	D-8
34028-009/00	D-5
35004-1063	D-7
35019-1027	D-7
35023-1032	D-7
35023-1045	D-7
35034-1074	D-7
36001-1120	E-7

Part No.	Grid. No.
36001-1131	E-7
36001-1162/00	E-7
36001-1253	E-7
36014-1105/00	E-8
36014-1106/00	E-8
39058-1051/00	D-13
39065-1051/00	D-13
39184-1056	C-10
41002-1154	D-9
41002-1155	D-9
41022-1032	D-9
41023-1002	D-9
41023-1020	D-9
41025-003	D-9
41025-006	D-9
41027-074	D-9
41028-073	D-9
41034-1039	D-11
41034-1040	D-10
41035-1466	D-10
41035-1467	D-11
41039-002	D-10
41048-017	D-10
41048-017	D-11
41050-012	D-11
41050-018	D-10
41053-002	D-11
41053-005	D-10
41060-014	D-10
41060-1026	D-10
41062-005	D-10
41063-001	D-10
41064-010	D-10
41068-1108/00	D-10
41068-1109	D-11
41068-1109/00	D-11
41069-026	D-10
41072-007	D-10
41072-007	D-11
41082-001	D-10
41085-003	D-11

Part No.	Grid. No.
41085-013	D-10
410B0600	D-12
410B0600	E-4
410B0800	D-4
410B1000	D-5
410B1200	D-5
410B1400	D-12
411B0500	D-13
411B0600	E-8
411B0800	B-11
411B1000	D-10
42010-005	D-11
42014-016	D-11
42032-002/00	D-11
42033-1026	D-11
42036-002	D-11
42037-003	D-11
42041-1065	D-11
42045-004	D-11
42045-005	D-10
42045-005	D-11
43001-1155	D-12
43002-1056	B-3
43007-028/00	D-12
43011-010	D-12
43012-001/00	D-12
43049-1051	C-5
43049-1052	C-6
44001-1382	D-14
44005-1105	D-14
44006-1105	D-14
44013-1056	D-14
44022-1053	D-14
44026-1101	D-14
44037-1061	D-14
44045-051	D-14
45014-1176	D-5
46019-1014	D-13
46075-1018	D-13
46091-1339	D-13
46091-1340	D-13

NUMERICAL PARTS INDEX AN-80

Part No.	Grid. No.
46092-1013	D-13
46098-004	D-3
461F0600	D-7
461F0600	E-8
461F0800	D-13
461F0800	D-14
461F0800	D-4
461F0800	E-3
461F1000	D-12
461F1000	E-11
461F1200	D-5
480J1600	B-10
480J1700	B-12
482J6000	C-10
482L5000	B-10
49006-1074	C-5
49006-1084	C-6
49019-1051	E-3
49019-1054	C-6
49019-1952	C-5
49047-1058	B-13
49078-1053	B-7
49078-1054	B-7
49118-1004	B-8
51001-1153	E-3
51024-1051	C-5
51036-1052	C-6
51048-1052	E-3
52005-1055	C-4
52005-1080	E-3
53001-1359/00	E-4
53029-1031/00	E-4
54001-1032	E-6
54005-1034	E-6
54012-1224	E-6
55020-1083	C-10
55028-1055	E-8
550D2015/00	D-12
550D2015/00	D-5
550D3025	D-11
550D3030	D-12

Part No.	Grid. No.
551A0306	B-9
554A0600	E-4
554A0800	D-12
56001-1203	D-13
56007-1297	E-14
56008-1007	E-14
56014-1054	F-3
56014-1055	F-3
56018-1280	F-3
56018-1397	F-3
56018-1398	F-3
56018-1477	F-3
56018-1478	F-3
56018-1479	F-3
56018-1479-K/00	F-3
56031-1143	F-3
59009-1025	E-4
59009-1027	E-4
59051-1123	B-10
59061-1001	B-11
59441-1051	D-13
59441-1052	D-13
600A0600	D-3
600A0800	B-10
601A6002Z	B-8
601A6200Z	B-11
601A6201	C-3
601A6203	C-3
601B6200	D-10
601B6201Z	D-11
601B6203	D-11
601B6300Z	D-10
601B6301Z	D-11
610A0404	B-9
670B1508	B-11
670B1509	C-6
670B1510	C-7
92001-021	D-11
92001-114	E-3
92001-1153	D-13
92001-1155	B-8

Part No.	Grid. No.
92001-1352	B-3
92001-1401	C-3
92001-1417	E-4
92001-1435	D-14
92001-1446	D-14
92001-1464	D-14
92001-1705	E-3
92001-1762	D-4
92001-1827	C-4
92001-1860	D-7
92001-1862	D-7
92002-1235	B-3
92002-1237	B-10
92002-1237	B-14
92002-1238	C-4
92002-1369	B-3
92002-1753	B-11
92003-003	D-12
92003-017	D-12
92004-1108	C-3
92004-112 /	B-3
92008-009	F-3
92009-1056	E-11
92009-1069	E-10
92009-1091	E-7
92009-1104	B-10
92009-1109	B-7
92009-1124	B-5
92009-1136	E-7
92009-1139	E-9
92009-1152	D-13
92009-1254	E-5
92009-1263	D-13
92009-1264	D-13
92009-1273	D-7
92009-1273	E-7
92009-1298	E-7
92009-1331	E-6
92015-042	D-12
92015-077	B-9
92015-1078	E-4

Part No.	Grid. No.
92015-1092	C-5
92015-1136	B-11
92015-1137	B-7
92015-1259	E-13
92015-1317	D-13
92015-1341	B-11
92015-1365	B-6
92015-1396	B-6
92015-1409	B-6
92018-005	F-3
92019-008	E-7
92019-014	D-13
92020-014	D-5
92022-024	D-7
92022-024	E-7
92022-077	B-8
92022-1143	E-7
92022-116	D-5
92022-1187	C-6
92022-1224	B-10
92022-1232	B-9
92022-1253	D-14
92022-1256	C-5
92022-1296	B-9
92022-1312	B-11
92022-1506	B-3
92022-1550	B-6
92022-1551	B-6
92022-1568	D-5
92022-165	E-8
92022-1698	C-6
92022-1699	C-6
92022-183	E-3
92022-228	D-7
92022-315	B-10
92026-1002	C-3
92026-1082	B-11
92026-1091	B-12
92026-1096	B-11
92027-1289	B-12
92027-129	D-7

Part No.	Grid. No.
92027-1354	E-4
92027-1442	B-11
92027-1461	C-10
92027-1733	B-8
92027-1897	B-9
92027-194	D-7
92028-1189	C-4
92033-1059	B-11
92033-1060	B-12
92033-1072	B-4
92033-1087	D-14
92037-1069	B-3
92037-1069	E-12
92037-1272	C-6
92037-1295	D-13
92037-1303	C-5
92037-1307	C-5
92037-1316	E-6
92037-1400	E-4
92037-1407	B-5
92037-1575	B-3
92037-1610	C-6
92037-192	C-4
92042-007	B-8
92043-039	D-12
92043-079	D-5
92043-1066	C-5
92043-1109	B-10
92043-1126	C-6
92043-1263	C-3
92043-1263	C-7
92043-1264	B-3
92043-1264	B-4
92045-1107	B-9
92045-1107	C-3
92046-1034	C-3
92047-013	D-14
92047-014	D-3
92048-009	D-3
92049-1048	C-3
92049-1062	B-7

NUMERICAL PARTS INDEX AN-80

Part No.	Grid. No.
92049-1071	D-14
92050-002	D-10
92050-063	D-10
92051-003	C-4
92051-005	C-3
92052-003	D-11
92055-004	D-10
92055-004	D-11
92055-012	C-4
92055-1078	C-6
92055-1097	B-12
92055-1104	D-14
92055-1127	C-5
92055-1136	C-4
92055-1141	C-4
92055-1177	B-3
92055-1178	B-3
92055-1231	B-3
92055-1236	C-5
92055-1237	C-5
92055-1238	C-5
92055-1239	C-5
92055-1257	B-3
92055-1305	C-6
92057-1060	B-8
92057-1175	D-11
92058-1056	D-11
92059-1167	C-4
92059-1219	C-5
92059-1220	C-5
92059-1427	C-5
92059-1427	C-6
92059-1428	C-5
92059-1428	C-6
92059-1514	E-4
92059-1592	C-6
92059-1593	C-6
92063-1121	C-5
92063-1313	C-6
92063-1314	C-6
92063-1341	C-6

Part No.	Grid. No.
92063-1342	C-6
92063-1343	C-6
92064-1116	C-6
92064-1158	C-5
92065-058	C-3
92066-1170	C-5
92066-1171	C-6
92066-1174	C-3
92069-017	E-5
92069-018	E-5
92069-018	E-9
92069-085	E-11
92069-1010	E-9
92069-1011	E-10
92070-1107	C-9
92071-1001	E-7
92071-1015	C-9
92071-1040	E-7
92072-006	D-4
92072-032	E-12
92072-1052	E-8
92072-1061	E-7
92074-004	E-8
92075-015	B-6
92075-099	E-4
92075-103	D-7
92075-1090	C-4
92075-121	D-7
92075-1288	E-4
92075-1289	E-4
92075-1370	D-7
92075-1392	C-10
92075-1415	C-10
92075-1621	B-6
92075-1675	D-6
92076-020	D-5
92081-020	B-10
92081-076	B-14
92081-1118	B-14
92081-1153	C-6
92081-1202	C-5

Part No.	Grid. No.
92081-122	B-10
92081-1276	B-10
92081-1326	B-11
92081-1332/00	D-12
92081-1334	E-9
92081-1356	E-4
92081-1398	C-6
92081-1566	B-11
92081-1569	E-4
92081-1686	C-5
92081-1692	C-5
92081-1693	C-5
92081-1694	C-5
92081-1766	D-10
92081-1766	D-11
92081-1866	B-8
92081-1867	C-6
92088-003	D-11
92090-006	D-3
92092-006	D-5
92092-1017	B-11
92093-1079	C-10
92104-002	E-14
92106-1001	E-14
92107-003	E-14
92107-005	E-14
92110-1024	E-14
92110-1038	E-14
92110-1102	E-14
92122-1017	B-11
92144-1107	B-14
92150-1450	B-14
92150-1556	C-3
92160-1036	B-14
92163-003	E-14
ESCOB-5857/00	C-10
ZCANA-AN-80	E-4